

2m cable,
optional Spiral cable 1-5m

Front board control panel
Pick-Up/Full-Mag/Safe/De-Mag

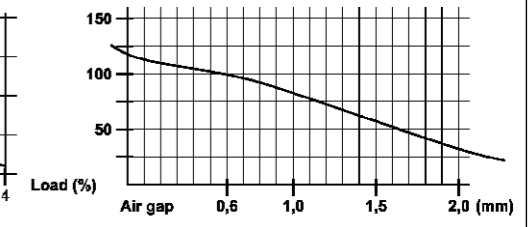
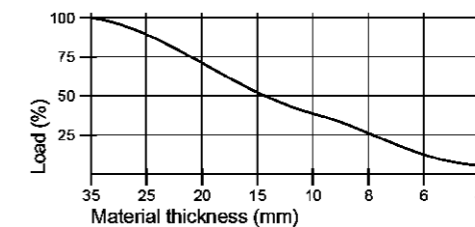
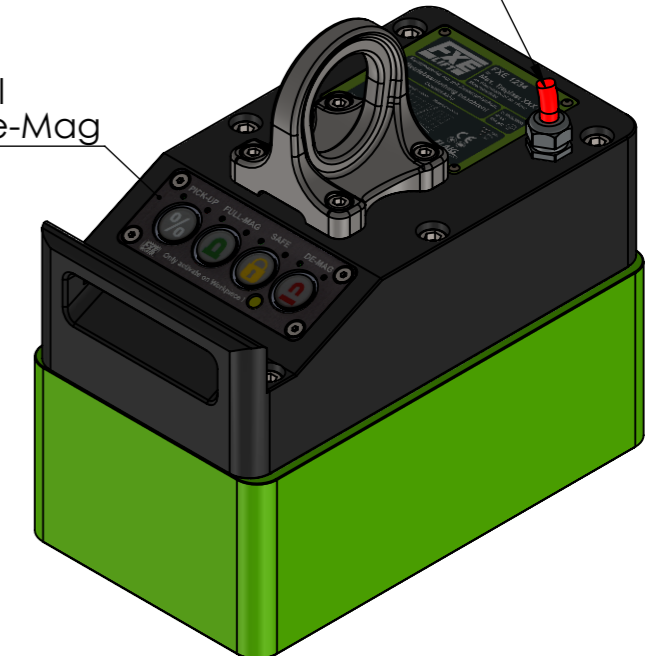

Specification FXE 800-100

Nominative Force: 29kN	lifting capacity EN 13155/WLL		
Materialthickness >35mm (100%)	WLL= 800kg		
5,7 kVA			
U: 380-480V Pulse	Protection Class IP 65		
R: 4,7Ω	Protectiv Earth SK I		
Max. Load capacity at sheets and 4-edge pipes			
T material thickness	Lmax (mm)	Wmax (mm)	Wll (kg)
>=35mm	2000	1000	800

Schutzvermerk nach DIN ISO 16016 beachten!
Nachdruck nur mit unserer Genehmigung!
All rights reserved according to DIN ISO 16016!
Reprint with our permission only!

	tolerance	-0,05 -0,2
	ISO	7168 M
	date	name
	drawn	24.10.2023
edit	27.06.2024	
appr.	27.06.2024	TW

material:	weight: 52kg
drawing no.:	0018529
description:	FXE 800-100
part no.:	10600803
sheet	1 / 1
A3	
scale: 1:3	Status: Freigegeben

02	Luftspaltkurve	27.06.2024	TW
rev.	change	date	name

