

2m cable/
optional Spiral cable 1-5m

Front board control panel
Pick-Up/Full-Mag/Safe/De-Mag

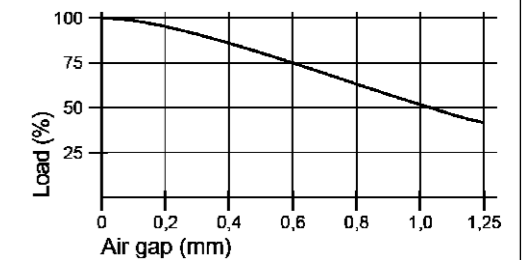
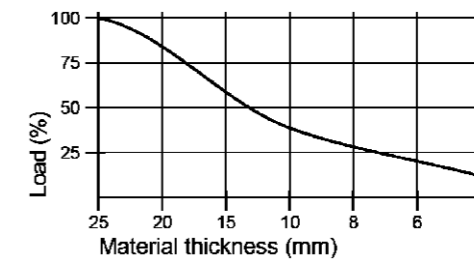
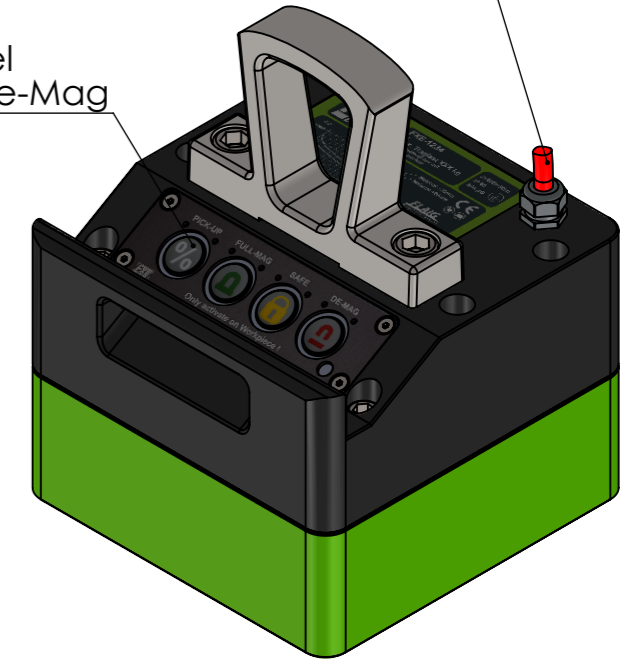

Specification FXE 1000-80

Nominative Force: 36kN	lifting capacity EN 13155/WLL
Materialthickness >25mm (100%)	WLL= 1000kg
4,2kVA	
U: 380-480V Pulse	Protection Class IP 65
R: 6,5Ω	Protectiv Earth SK I

Schutzvermerk nach DIN ISO 16016 beachten!
Nachdruck nur mit unserer Genehmigung!
All rights reserved according to DIN ISO 16016!
Reprint with our permission only!

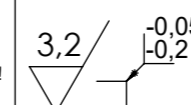

tolerance
ISO 7168 M

material: weight: 39.00

drawing no.: **0015442**

Max. Load capacity at sheets and 4-edge pipes

T material thickness	Lmax (mm)	Wmax (mm)	Wll (kg)
>=8mm	2000	1500	200
>=10mm	2000	1500	300
>=15mm	2000	1500	600
>=25mm	2000	1500	1000

date	name
drawn 24.10.2023	TW
appr. 24.10.2023	TW

FLAIG
Magnetsysteme
www.flraig-te.de

description: **FXE 1000-80**

part no.: **10601002**

sheet
1 / 1
A3

scale: 1:4 Status: Freigegeben