

2m cable
optional Spiral cable 1-5m

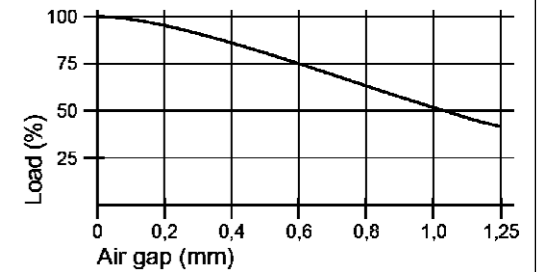
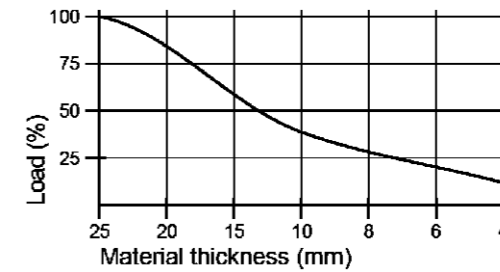
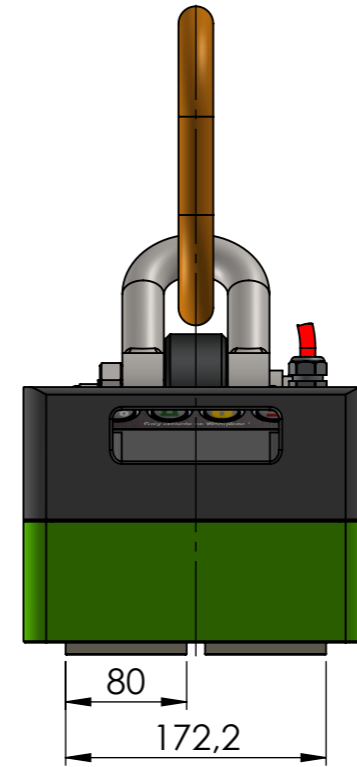
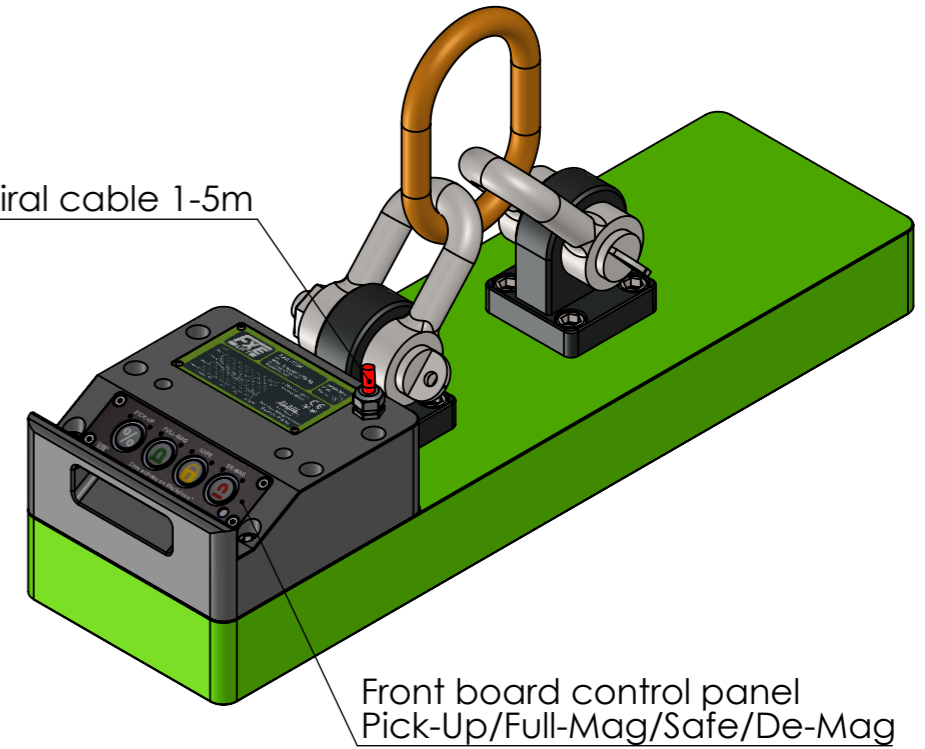

Specification FXE 4000-80

Nominative Force: 144kN	lifting capacity EN 13155/WLL
Materialthickness >25mm (100%)	WLL= 4000kg
15 kVA	
U: 380-480V Pulse	Protection Class IP 65
R: 1,8Ω	Protectiv Earth SK I

Max. Load capacity at sheets and 4-edge pipes

T material thickness	Lmax (mm)	Wmax (mm)	Wll (kg)
>=8mm	3000	2000	800
>=10mm	3000	2000	1200
>=15mm	3500	2000	2400
>=25mm	4000	2500	4000

Schutzvermerk nach DIN ISO 16016 beachten!
Nachdruck nur mit unserer Genehmigung!
All rights reserved according to DIN ISO 16016!
Reprint with our permission only!

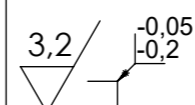

tolerance
ISO 7168 M

material: weight: 132.00

drawing no.: **0018553**

description: **FXE 4000-80**

part no.: **10604002**

sheet
1 / 1
A3

02	Tabellenwerte	19.10.2023	TW
rev.	change	date	name

FLAIG
Magnetsysteme
www.flraig-te.de

scale: 1:5 Status: Freigegeben