

2m cable,
optional Spiral cable 1-5m

Front board control panel
Pick-Up/Full-Mag/Safe/De-Mag

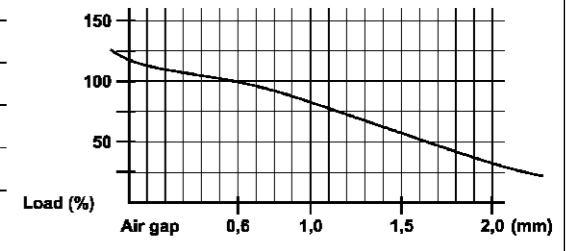
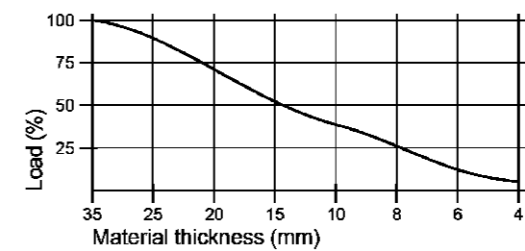
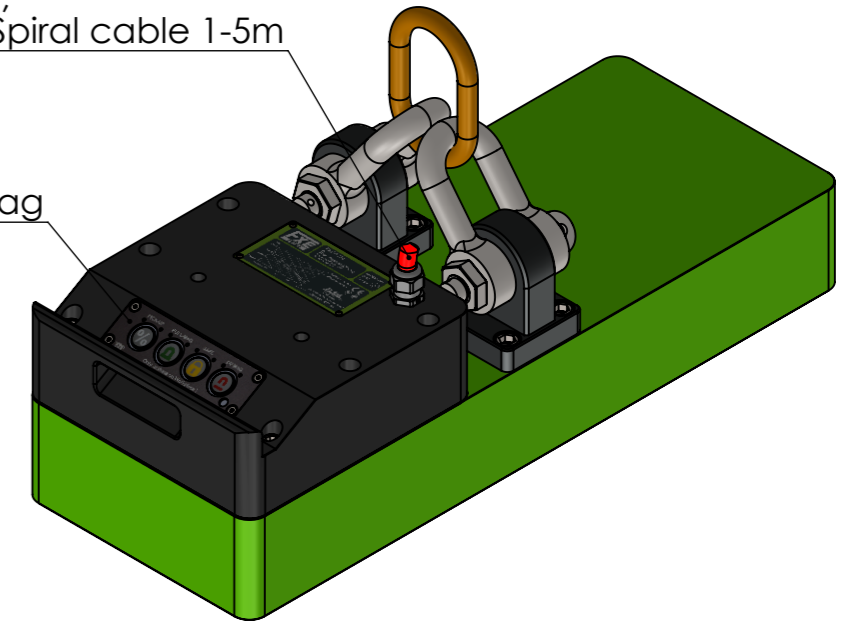

Specification FXE 4800-100

Nominative Force: 174kN	lifting capacity EN 13155/WLL		
Materialthickness >35mm (100%)	WLL= 4800kg		
15,9kVA			
U: 380-480V Pulse	Protection type IP 65		
R: 2 x 1,7Ω	Protection category SK I		
Max. Load capacity at sheets and 4-edge pipes			
T material thickness	Lmax (mm)	Wmax (mm)	Wll (kg)
>=10mm	3000	2000	1200
>=20mm	4000	2500	3000
>=35mm	4000	3000	4800

Schutzvermerk nach DIN ISO 16016 beachten!
Nachdruck nur mit unserer Genehmigung!
All rights reserved according to DIN ISO 16016!
Reprint with our permission only!

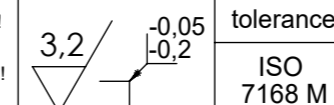

date	name
drawn 19.10.2023	TW
edit 27.06.2024	
appr. 27.06.2024	TW

FLAIG
Magnetsysteme
www.flraig-te.de

material:	weight: 202kg
drawing no.:	0017801
description:	FXE 4800-100
part no.:	10604803
scale: 1:6	Status: Freigegeben

sheet
1 / 1
A3