

Crane lifting eye optional
Article number: 910020255

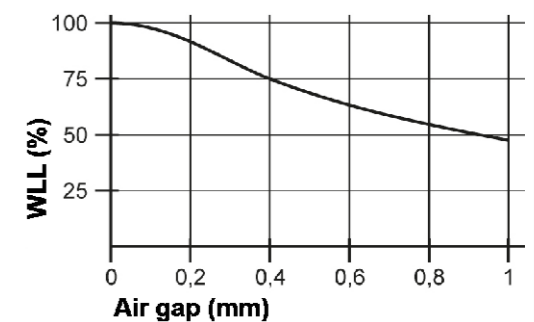
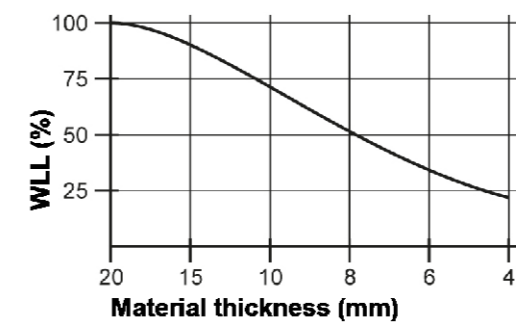
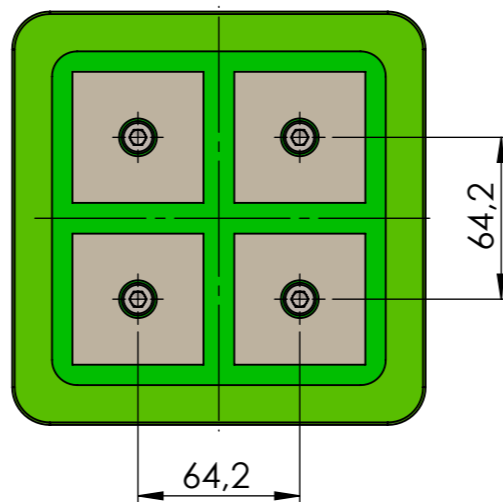
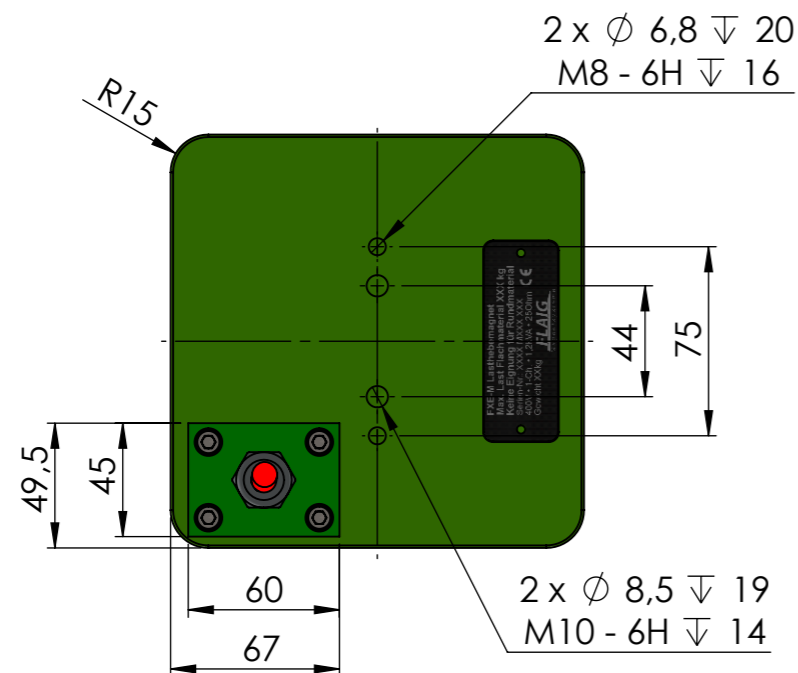
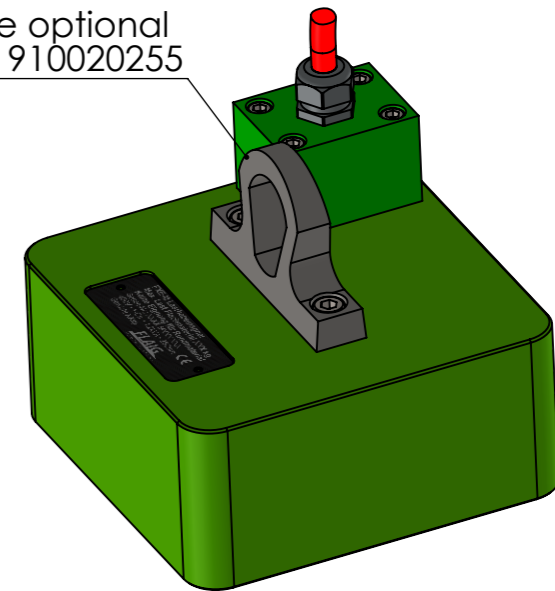

Specification FXE-M 300-50+		Schutzvermerk nach DIN ISO 16016 beachten! Nachdruck nur mit unserer Genehmigung! All rights reserved according to DIN ISO 16016! Reprint with our permission only!				tolerance	material:	weight: 14.70
Nominative Force: 15,2kN	lifting capacity EN 13155/WLL			drawn	11.02.2021	MF	drawing no.:	0012940
Materialthickness >15mm (100%)	300kg			edit	29.04.2022		description:	FXE M 300-50+
2,2kVA				appr.	11.04.2022	TW		
U: 380-480V Pulse	Protection Type IP 65						part no.:	10610302
R: 12,4Ω	Protection category SK I						sheet	1 / 1
		rev.	change	date	name	scale: 1:3	Status: Freigegeben	A3