

Crane lifting eye optional
Article number: 911011005

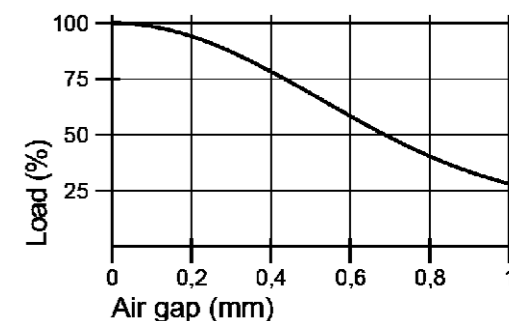
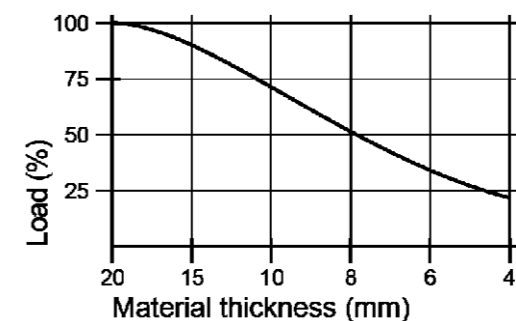
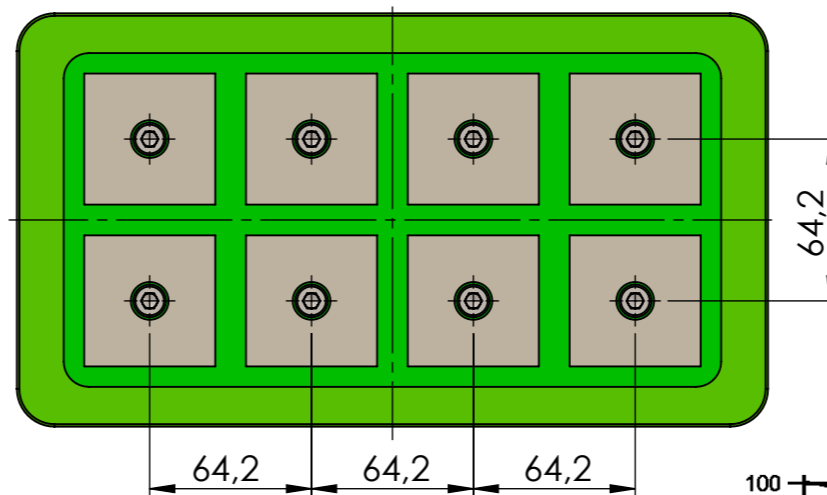
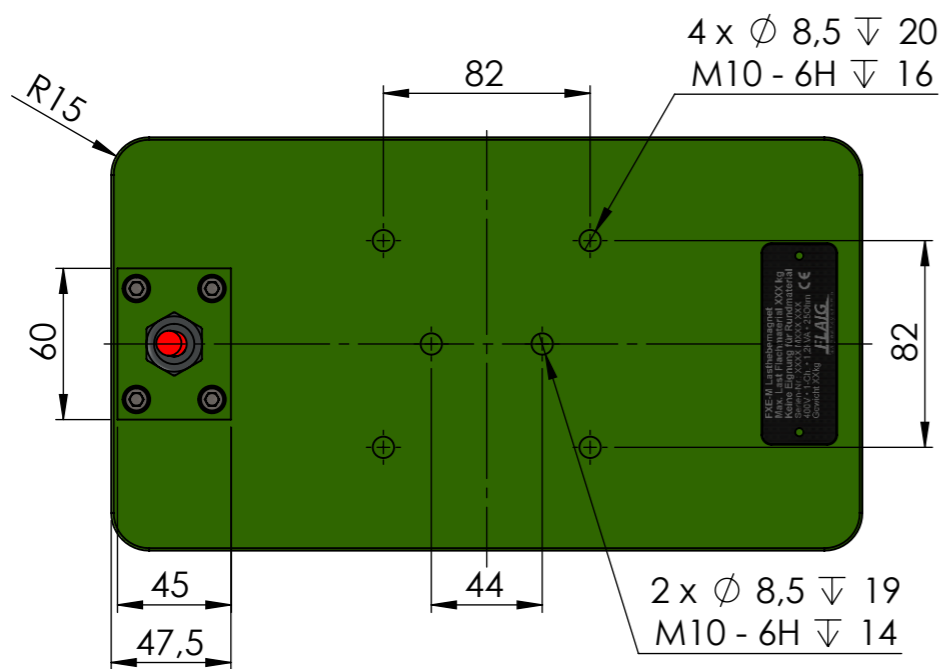
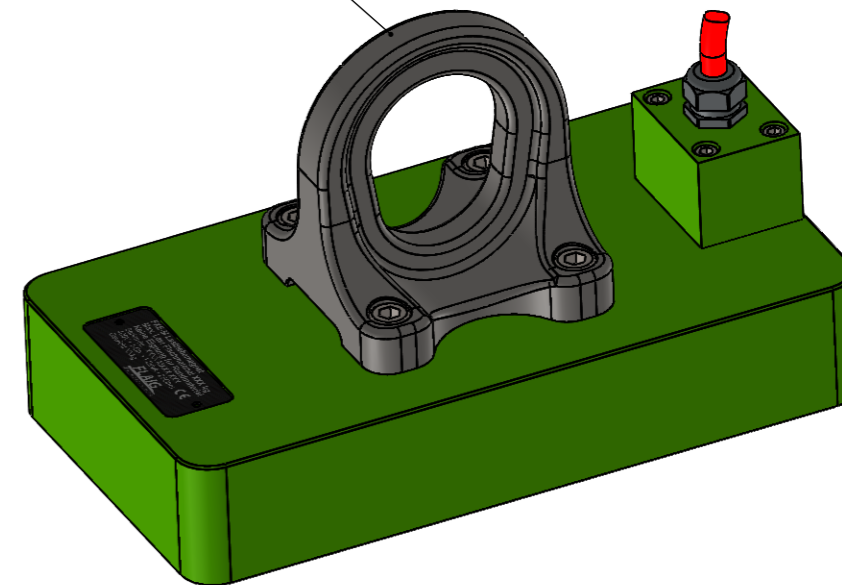

Specification FXE-M 750-50

| | |
|--------------------------------|-------------------------------|
| Nominative Force: 30,4kN | lifting capacity EN 13155/WLL |
| Materialthickness >15mm (100%) | 750kg |
| 2,2kVA | |
| U: 380-480V Pulse | Protection Type IP 65 |
| R: 12,6Ω | Protection category SK I |

Schutzvermerk nach DIN ISO 16016 beachten!
Nachdruck nur mit unserer Genehmigung!
All rights reserved according to DIN ISO 16016!
Reprint with our permission only!

| | | | |
|----------------------|------------------------|---------------------------|--------------------------------|
| | Zul. Abw. | Material: | Gewicht: 20.00 kg |
| | ISO 7168 M | Zeichnungsnummer: 0012960 | |
| | Datum | Name | Benennung: FXE M 750-50 |
| | Erstellt 15.02.2021 MF | | |
| Gepr. | | | |
| Freig. 12.05.2022 TW | | | |



| | |
|-------------------------|---------------------|
| Artikelnummer: 10610701 | Blatt 1 / 1 |
| Maßstab: 1:3 | Status: Freigegeben |

| Rev. | Änderung | Datum | Name |
|------|----------|-------|------|
| | | | |