

Crane lifting eye optional  
Article number: 911010605

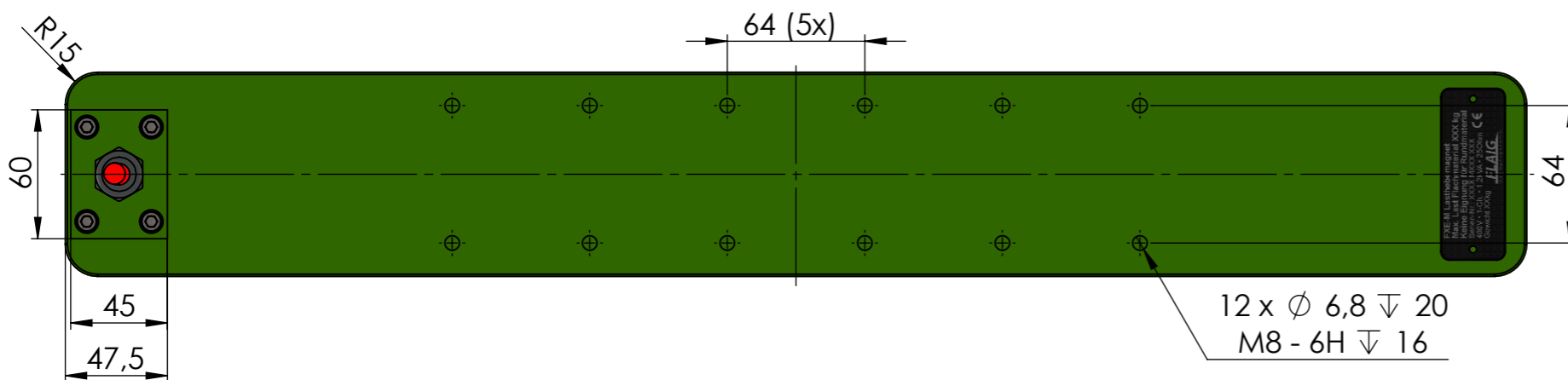

12 x  $\varnothing$  6,8  $\nabla$  20  
M8 - 6H  $\nabla$  16

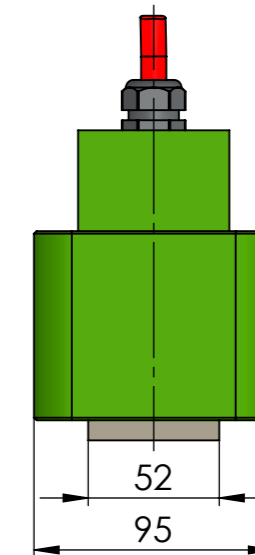
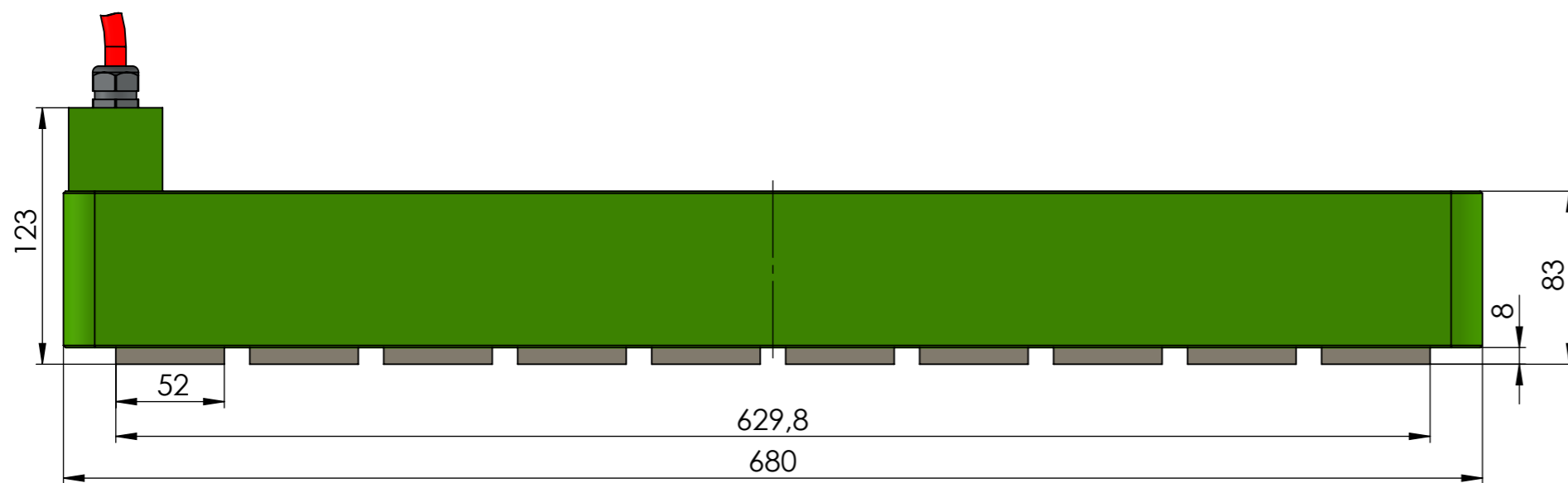
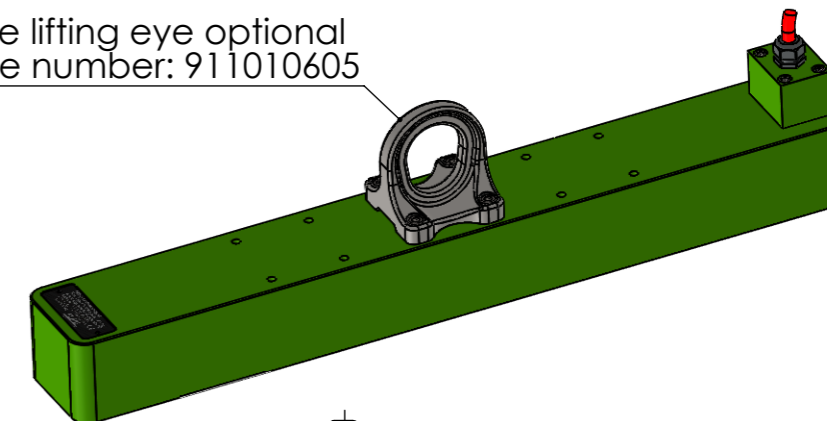
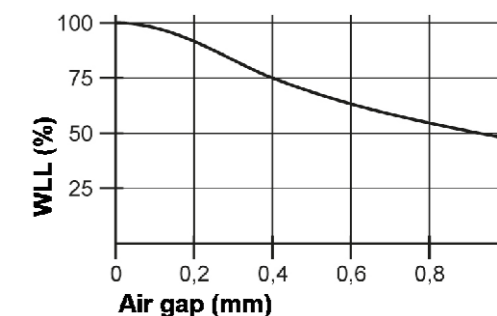
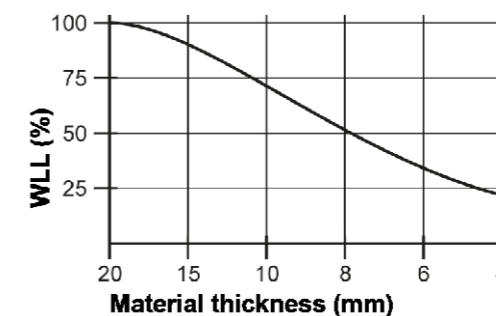

Specification FXE-M 1000-50+		Schutzvermerk nach DIN ISO 16016 beachten! Nachdruck nur mit unserer Genehmigung! All rights reserved according to DIN ISO 16016! Reprint with our permission only!		3,2 / -0,05 / -0,2 tolerance		material:		weight: 35.30	
Nominative Force: 38kN	lifting capacity EN 13155/WLL	drawn	01.02.2021	MF	ISO 7168 M	drawing no.:	0012837		
Materialthickness >15mm (100%)	1000kg	edit	23.05.2022			description:	FXE M 1000-50+		
4,5kVA		appr.	23.05.2022	TW		part no.:	10611011		sheet 1 / 1
U: 380-480V Pulse	Protection Type IP 65	FLAIG Magnetsysteme www.flraig-te.de		scale: 1:3		Status: Freigegeben		A3	
R: 6Ω	Protection category SK I	rev.	change	date	name				