

Crane lifting eye optional  
Article number: 911012005

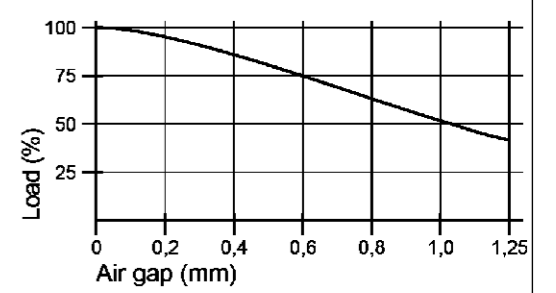
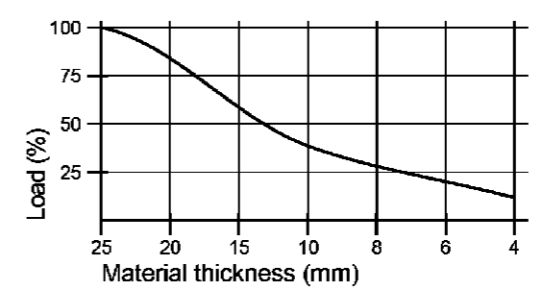
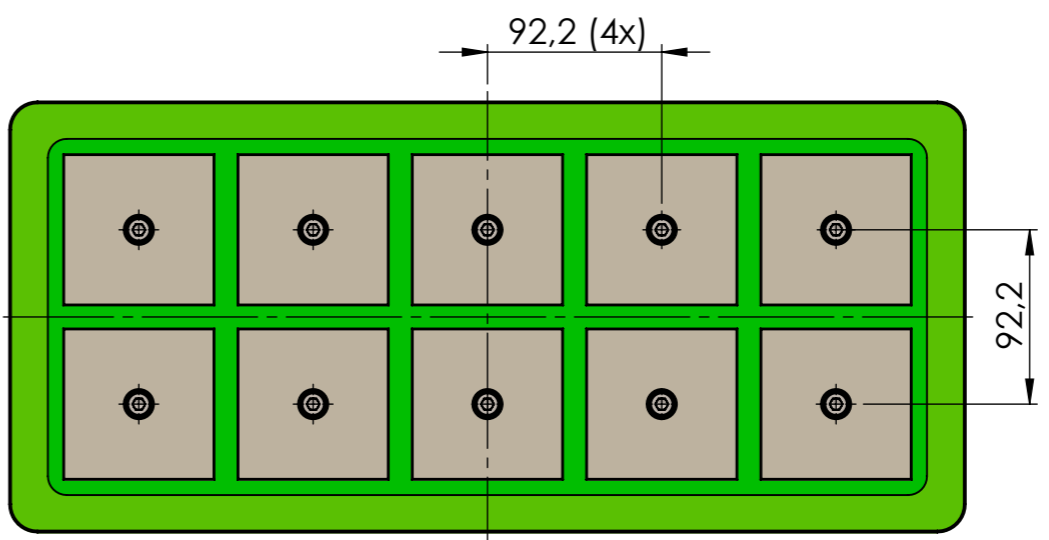
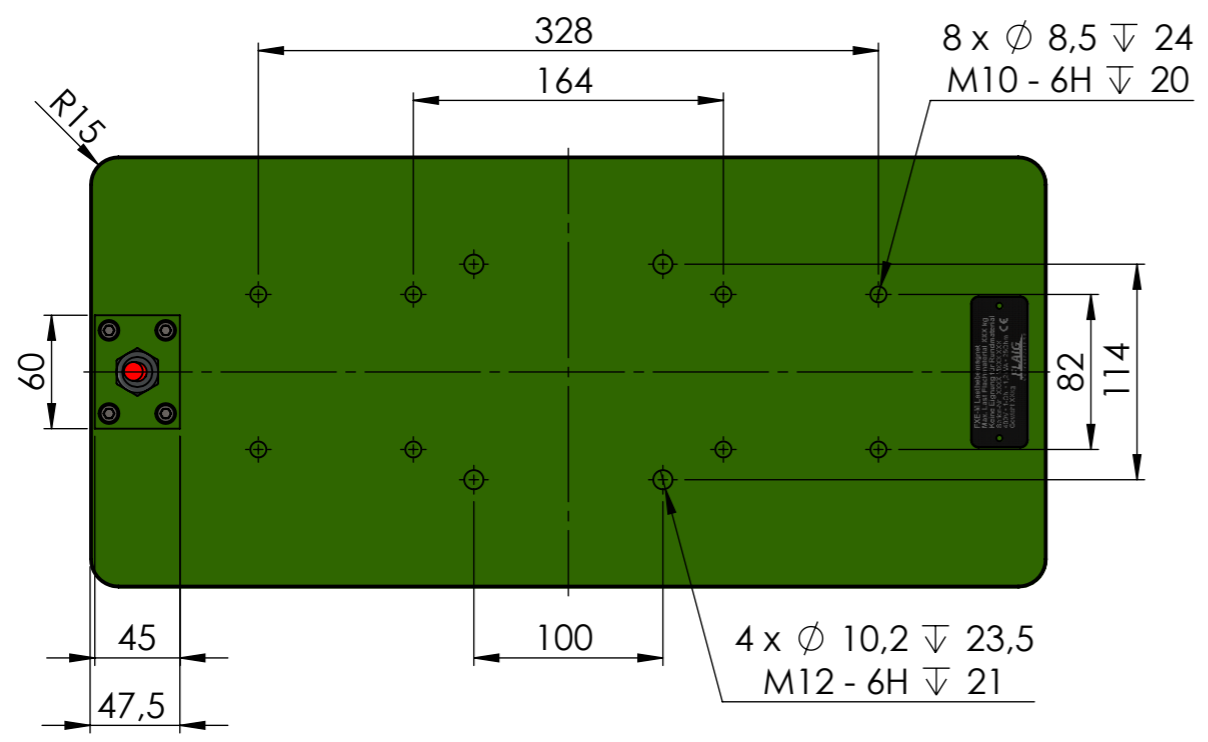
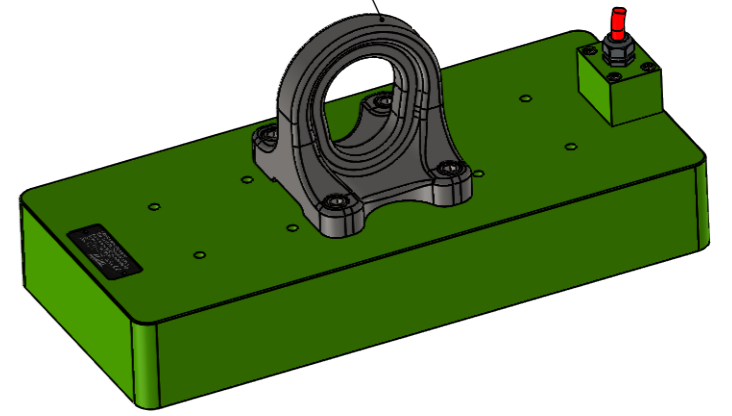

Specification FXE-M 2500-80	
Nominative Force: 90kN	lifting capacity EN 13155/WLL
Materialthickness >25mm (100%)	2500kg
10,8kVA	
U: 380-480V Pulse	Protection Type IP 65
R: 2,5Ω	Protection category SK I

Schutzvermerk nach DIN ISO 16016 beachten! Nachdruck nur mit unserer Genehmigung!		3,2 / -0,05 / -0,2 tolerance	material:	weight: 72.00
All rights reserved according to DIN ISO 16016! Reprint with our permission only!			ISO 7168 M	drawing no.:
date	name		description: <b>FXE M 2500-80</b>	
drawn 19.08.2022	TW		part no.:	10612502
edit 19.08.2022			sheet	1 / 1
appr. 19.08.2022	TW		A3	
 www.flraig-te.de		scale: 1:4	Status: Freigegeben	