

Crane lifting eyes optional
Article number: G1060AH-4

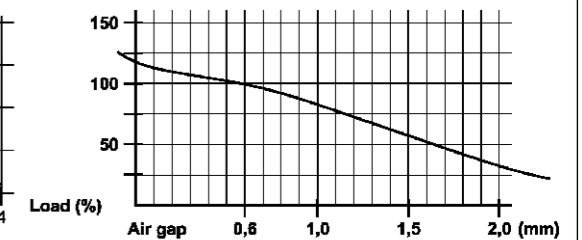
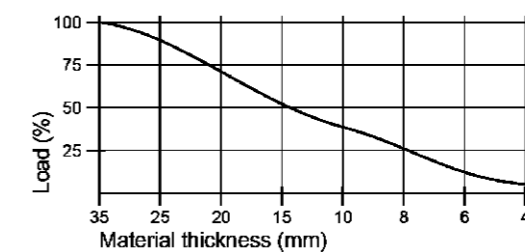
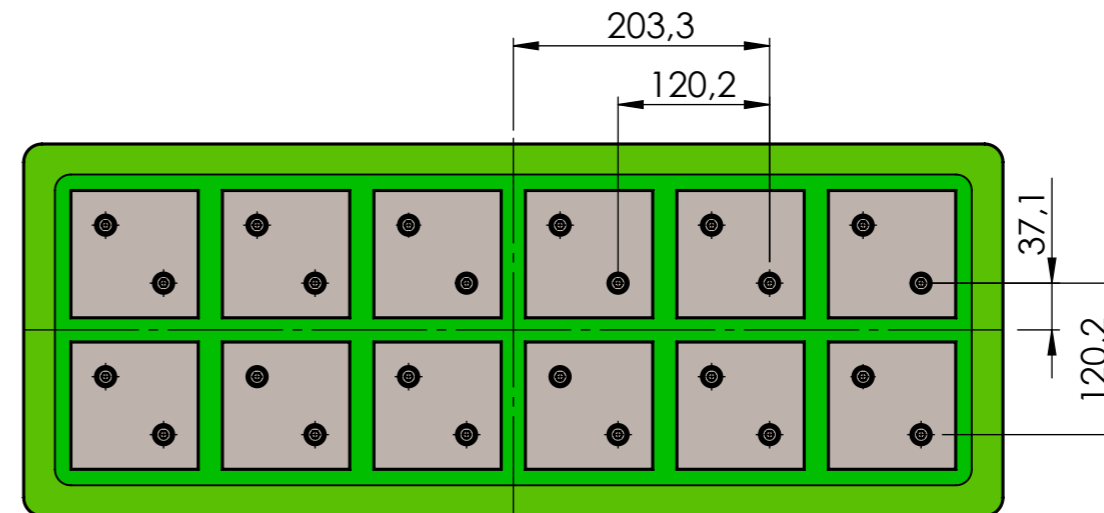
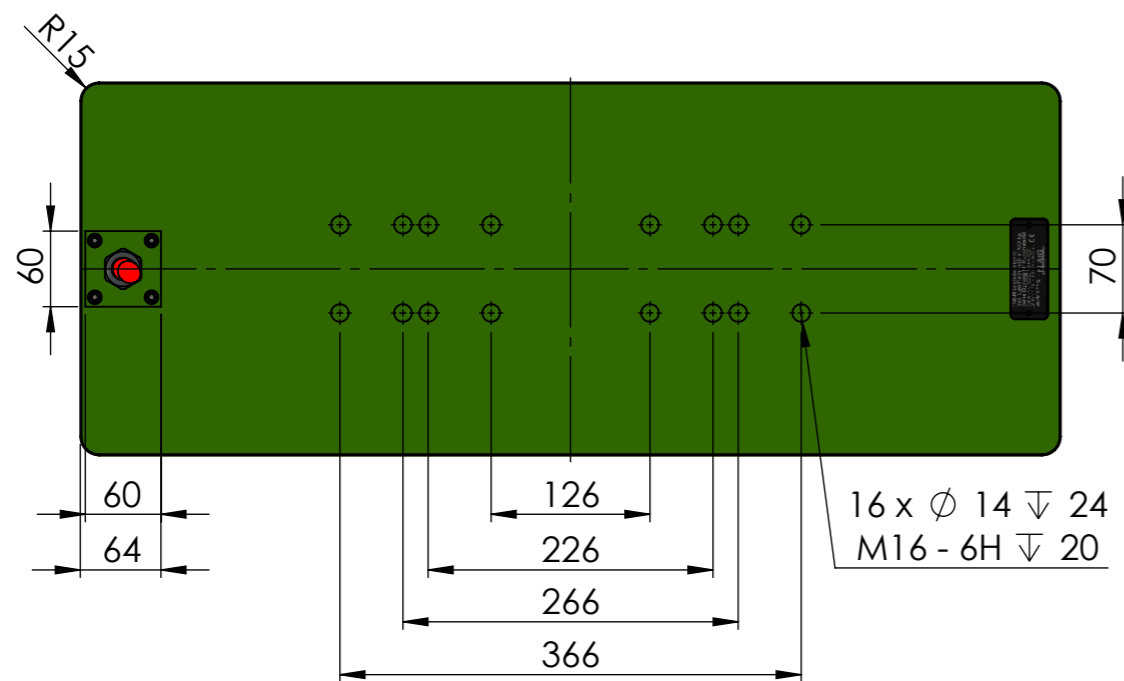
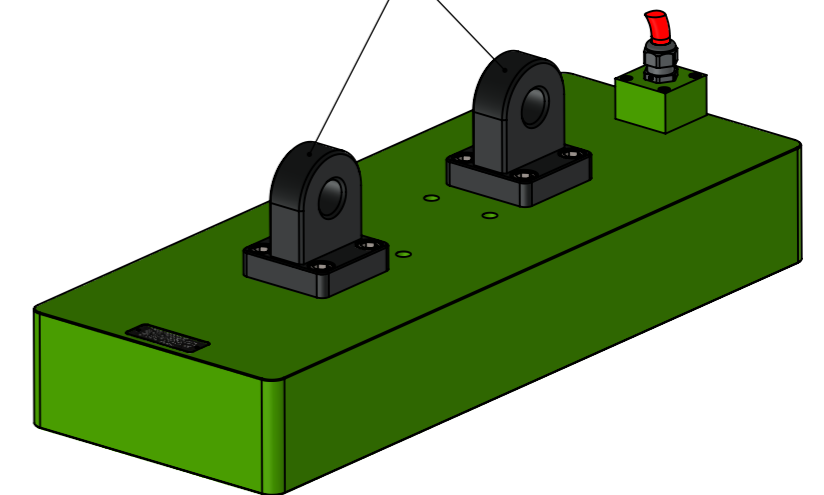

Specification FXE-M 4800-100

Nominative Force: 174kN		lifting capacity EN 13155/WLL		Schutzvermerk nach DIN ISO 16016 beachten! Nachdruck nur mit unserer Genehmigung!		3,2 / -0,05 / -0,2 tolerance		material:		weight: 202.60	
Materialthickness >35mm (100%)		4800kg		All rights reserved according to DIN ISO 16016! Reprint with our permission only!		ISO 7168 M		drawing no.:		0013223	
2x16,9kVA						date		description:		FXE-M 4800-100	
U: 380-480V Pulse		Protection Type IP 65				drawn 22.08.2022 TW					
R: 2x1,6Ω		Protection category SK I				edit 27.06.2024		part no.:		10614803	
						appr. 27.06.2024 TW		sheet		1 / 1	
								scale: 1:6		Status: Freigegeben	
								part no.:		10614803	
								sheet		1 / 1	
								A3			

FLAIG
Magnetsysteme
www.flraig-te.de