

siegmund

WELDING TABLES AND CLAMPING SYSTEMS

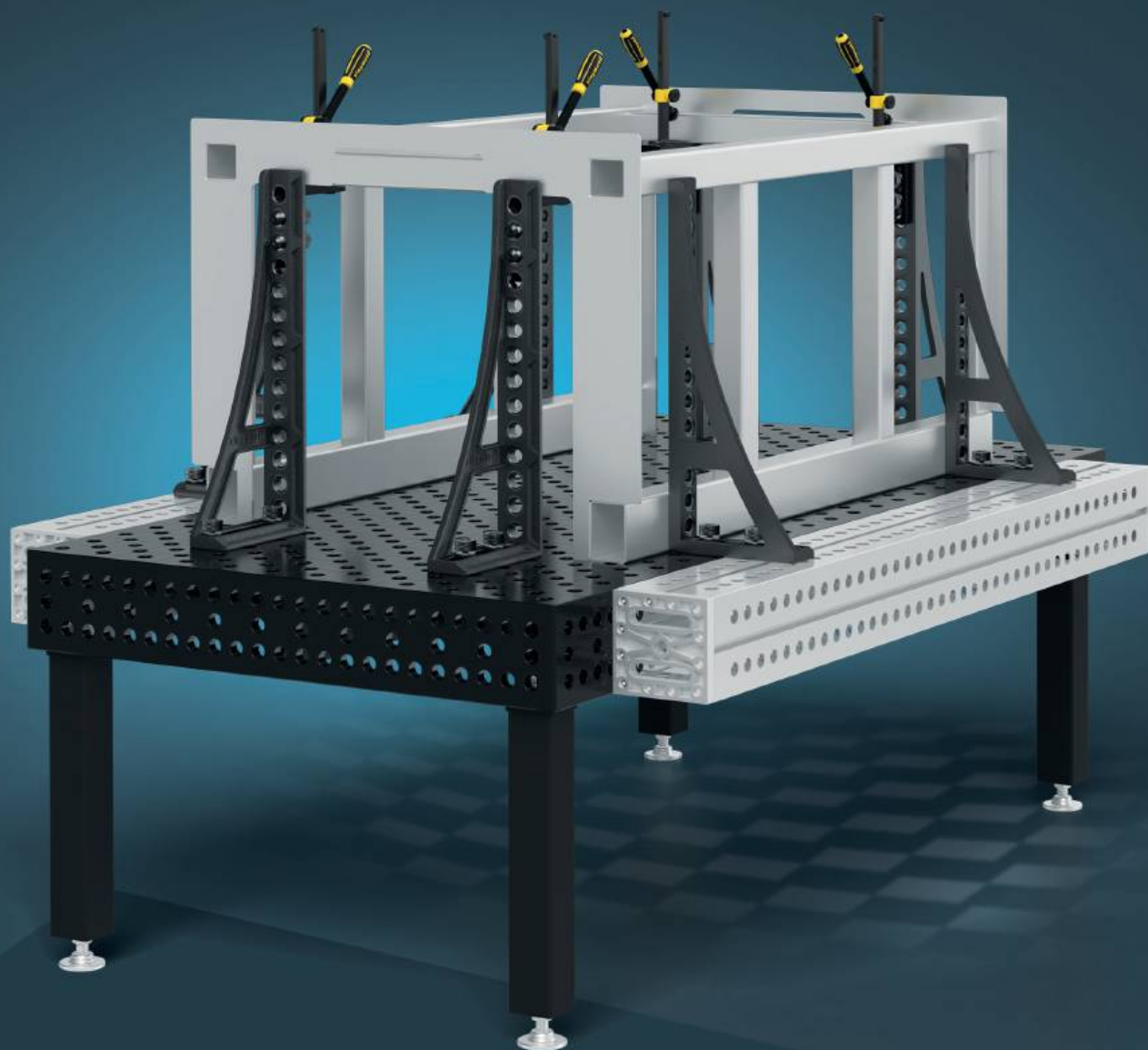

**PRECISION IN PERFECTION:
WELDING TABLES FOR
THE HIGHEST DEMANDS**





Icon index

Siegmund systems

- 28** System 28
Light to Heavy Duty Fabrications
- 22** System 22
General Purpose Fabrication
- 16** System 16
Fine Details Fabrication

Materials

- AL-TI Aluminum-Titanium**
lightweight and high-strength material, hardness of nitrided cast steel is not achieved
- AL Aluminum**
for stainless steel processing
- PA Polyamide**
for stainless steel and aluminum processing to prevent surface damage
- E Stainless Steel**
for scratch-resistant surfaces (rust prevention)
- X8.7 Through-hardened tool steel X8.7**
- X8.8 Through-hardened tool steel X8.8**
- 750 Premium steel S355J2+N**

Material characteristics

- Scratch resistant & Corrosion resistant**
The surface provides relatively good corrosion protection in dry environments
- N Nitration**
improves impact resistance and protects against weld spatter adhesion
- BAR BAR-coating (Black-Anti-Rust-coating)**
smooths the surface and increases the rust prevention
- B Blueing**
Protection against corrosion

Product characteristics

- 100 Scale**
- Table side panel**
- Extra high table side panel**
- Hexagonal Slot**
- Hexagon socket**
- External hexagon**

Boring Grid

- Diagonal grid**
- 25x25 mm / 50x50 mm / 100x100 mm Grid**

The new edition of our popular aluminum profiles

Siegmund aluminum profiles impress with their ideal combination of high stability and low weight, a key reason for their popularity among users. Building on this success, we have further developed the profiles with new, practical features.

In addition to proven advantages such as low weight, use as a table extension, or vertical clamping surface, the aluminum profiles now feature integrated square clamping plates on the front ends for particularly quick and easy installation. This is complemented by the new hexagonal slot, which opens up additional, flexible mounting options.

- 1 Clamping Plate**
- 2 Hexagonal Slot**
- 3 Boreholes**

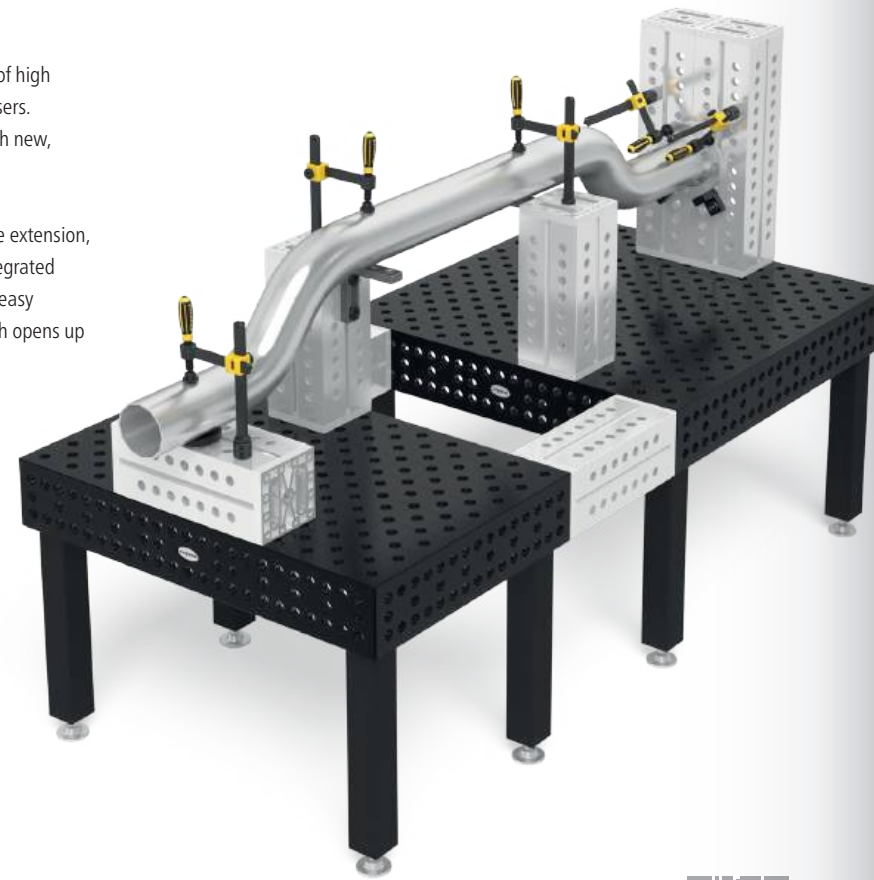
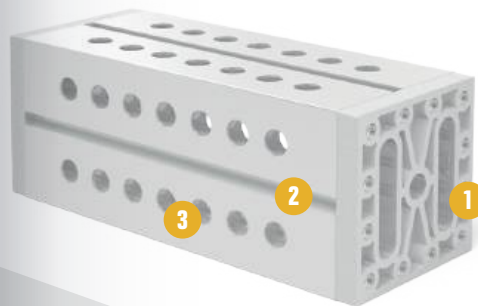

070 116 158

www.siegmund.com/alu-squares



085 125 171



Lifting lug

The lifting lug offers a reliable and simple solution for the safe transport of Siegmund welding tables and U-Squares.

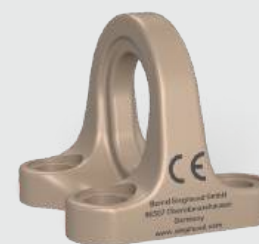

www.siegmund.com/lifting-lug



Product overview

	SYSTEM	28	22	16		SYSTEM	28	22	16	
Siegmund welding tables The perfect working basis		010	042	098	134		062	112	152	
Hexagon Slot Table Advantages of welding tables and slot tables combined		050					064	114	154	
Lifting platforms Easily lift the heaviest loads		052	104	142			070	116	158	
Rotating table height adjustable Quick and easy adjustment for an ideal working height		054	106	144			072	118	160	
Mobile lifting table Ergonomic pain free working		055	107	145			076	120	164	
Siegmund Workbench The revolutionary workbench		028					080	122	168	
Siegmund Workstation The all-rounder in every workshop		030	056	108	146		084	124	170	
Octagonal tables Welding tables for manipulators		060	110	150			086	126	172	
Siegmund Welding Cell Introduction into automation		036					088	128	174	
Modular laser welding cell Safe and efficient manual laser welding		034					090	130	176	
Zero point clamping system Exchange welding fixtures easily and flexibly		037					180			
Clamping system for serial devices with templates		037					180			
Rail System Standard same track width for all table sizes		032	092				184			
Stops Versatile clamping options										
Squares Working in three dimensions										
Aluminum profiles Lightweight clamping tools										
Bolts Fastening and connecting										
Clamps & Accessories Fastening of workpieces										
Prisms & Supports Solid support surfaces										
Accessories Practical solutions for everyday work										
Sub Table Box Lockable storage space										
Bench vices Safe clamping of workpieces										
Table press Prestressing and straightening										
Magnetic Clamping Technology Clamping without interference contours										
Connecting Elements Cross-system solutions										
Maintenance products Cleaning and maintenance										
Positioner Easy positioning										

= Product Information



WELDING TABLES FROM THE WORLD'S MARKET LEADER

Success story from Oberottmarshausen

Over 30 years ago, Bernd Siegmund founded the company, which is now run by his son, Daniel Siegmund, in the second generation. As the world's number 1 in the field of welding tables, we are represented globally with five European locations and a sales network in over 60 countries.

Our products stand for maximum functionality and exclusive design and are used in almost all industries. In addition to machine, plant, metal and vehicle construction, they are particularly popular in prototype construction and series production with and without robot connection. The welding and clamping table systems are based on a well thought-out and flexible modular system. In combination with our large variety of accessories, we offer a simple and time-saving solution for every challenge.

The enthusiasm of our customers encourages us to new developments and innovative solution concepts. Our aim is to stick to this vision and to constantly develop ourselves and our products. We are able to do this with the help of our employees, who are committed to the company every day with heart, mind and energy.

With innovative strength, determination and the consistent pursuit of our visions, we not only want to maintain our success and our world market leadership, but continue to expand it.

The most important locations for welding table and accessory production

The Siegmund Group has around 75000 square meters of office, production and storage space available on a total of 160000 square meters of land.



Deggingen (D)

Mechanical production of welding tables, castings and aluminum profiles.



Skawina (PL)

Production of welded parts and welding tables.



Lublin (PL)

Production of welding tables and accessories.



Oberottmarshausen (D)

Approx. 4.000 welding and clamping tables and approx. 1 million accessories are stored on 18.000 square meters of hall space.

WHY SIEGMUND?

Save time and money with a welding table from Siegmund

Opt for a Siegmund table and save money. Thanks to the top quality of our welding tables, you get a tool with which you can work much more precisely and with a lower error rate. With the help of the modular system, you can combine welding tables, U-squares, stops etc. within a very short time and generate countless devices from them. This reduces the set-up time and saves storage space and costs.

Therefore Siegmund:

- ✓ 100.000 times in use worldwide
- ✓ high customer satisfaction
- ✓ 100% repeatability
- ✓ low set-up time / time saving
- ✓ No welding distortion
- ✓ Significantly less rework
- ✓ Highly resilient
- ✓ Rapid tooling changes
- ✓ Same basis for every project

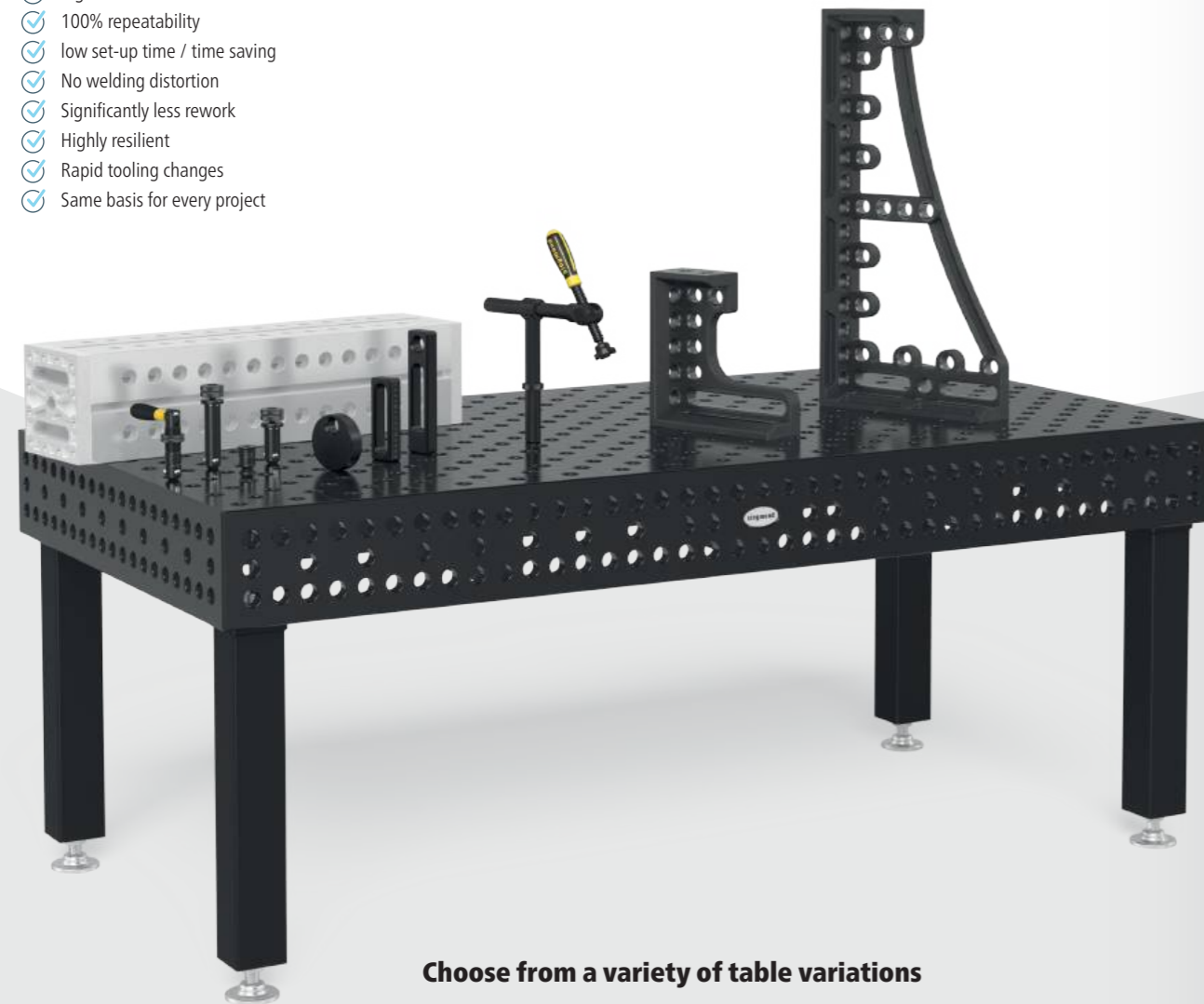

Choose from a variety of table variations

Our welding and clamping tables are available in the three sizes System 16 (borehole diameter 16 mm), System 22 (borehole diameter 22 mm) and System 28 (borehole diameter 28 mm). Based on these basic versions, you can choose between a large selection of materials, sizes, grid types and table legs. We offer the right working basis for every application.

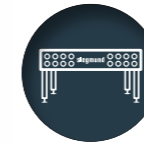

Siegmund

As the world market leader in the field of welding tables, with a dealer network in over 60 countries, our tables are in use 100.000 times over.



Quality

Siegmund stands for product innovations, high-quality materials and accurate processing. Our large development team works together with our customers on the constant further development of our products.



Storage capacity

Our Principle Aim: Availability from Stock! Approx. 4.000 welding and clamping tables and approx. 1 million accessories are stored on 18.000 square meters of hall space.



Hardest welding tables

The extraordinary hardness of the Extreme tables is achieved through specially developed special alloys and the subsequent plasma nitriding and BAR coating. The surface flatness is retained even after years of use.



Surface-hardened accessories

Our plasma nitriding is a unique surface finish that better protects our accessories from rust, scratches and weld spatter.



Innovative modular system

Modular, compatible, individual: workbenches, welding tables and clamping systems according to your requirements.



WE ARE A GLOBAL SUPPLIER

A basis of the world market leader is the close cooperation with selected trading partners.

Thanks to our worldwide sales network, there is also a qualified contact person in your area who will work with you – and in a personal consultation – to develop tailor-made solutions in your national language. Our various media are now also available in more than 36 languages. Every day craftsmen and industrial enterprises are relying on the steadiness of Siegmund welding tables, in more than 60 countries.



WE HAVE BEEN AWARDED

Maximum functionality and excellent design

All the awards we have received in the past at international design competitions are a recognition and incentive at the same time, to continue on this creative and innovative path with enthusiasm. We invite you to join us!

Our Company

We as a company have also received several awards as a medium-sized company with high innovative strength and strong growth.

BAYERN'S BEST 50
PREISTRÄGER 2019



Latest awards

We are very pleased that our products have regularly won over the specialist juries of international awards since 2012. We have compiled the most recent awards for you here.



WS161208
Siegmund Workbench



reddot winner 2024



160130.SE.RC1
Welding Cell 2400 - Black Edition



DESIGN AWARD 2023



reddot winner 2023
industrial design

WE ARE SPORTY

Strong partners in sport carry our name into the world, give our brand even more meaning and ensure enthusiasm and emotional moments.



BASKETBALL

German Basketball League
EuroLeague



German Ice Hockey League



2. German Basketball League



German Football League



SMALL OR LARGE PARTS TO BE WELDED?

With our welding tables, you can complete your tasks quickly and precisely.

Thanks to the boreholes in our welding tables, an extremely flexible and versatile clamping surface is created. This gives you the opportunity to quickly and easily produce a wide variety of constructions using squares, stops and clamps. The excellent precision of our welding tables enables you to position the components exactly and thereby achieve very good repeatability. We offer a perfectly coordinated modular system for every application, with which you can work conveniently and efficiently.

- ✔ modular system for everyone
- ✔ exact clamping of components
- ✔ convenient and efficient work
- ✔ Time saving through easy handling

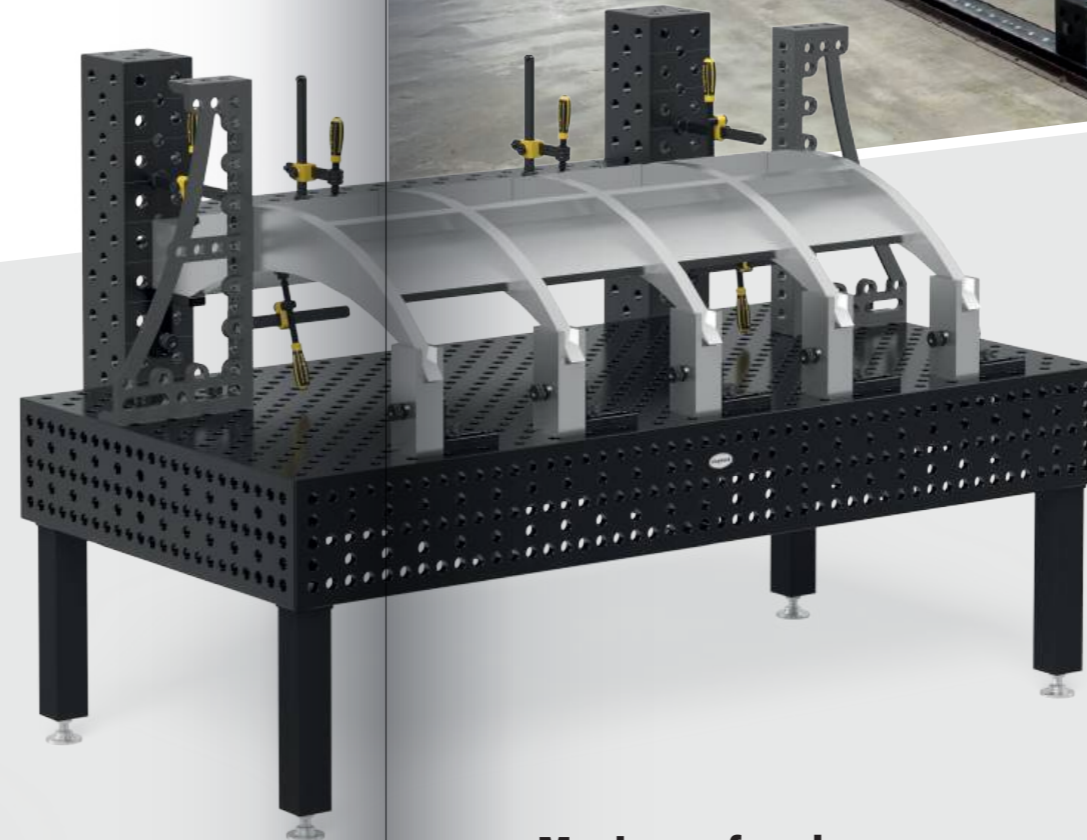
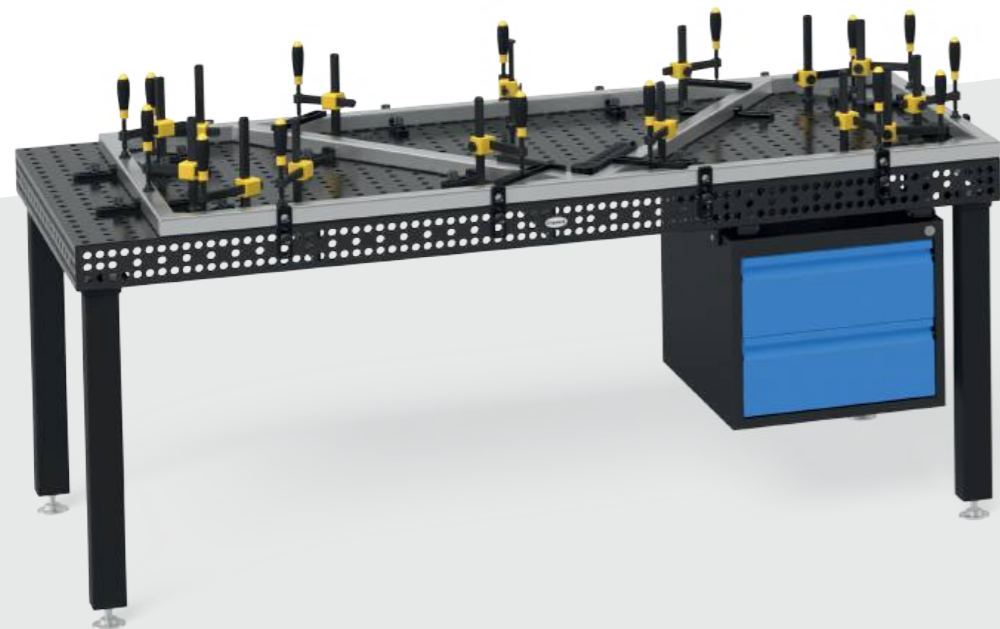

Flexibility that inspires

With a Siegmund welding table, you are well equipped for tasks of all dimensions. Regardless of whether it is individual production, series production or custom-made products, we offer you a coordinated and modular system for everyone in the best quality and with maximum flexibility.



Unlimited possibilities

With our rail systems, platform systems or manipulators, no project is too big for you. From building bridges or roller coasters to the production of buses and much more, we are happy to work with you to develop special solutions according to your individual needs and challenges.

Maximum freedom

Thanks to our modular system, your Siegmund tables easily grow with your tasks and requirements. Expand your work surface in every dimension, e.g. by connecting tables with U-squares or aluminum profiles.

CHOOSE YOUR SYSTEM

Our Siegmund modular system is based on three different bore sizes. The bore size defines the system. All tool parts and sets can be used on all table series within one system. If you want to work across systems, we also offer an extensive range of connecting elements.



Light to Heavy Duty Fabrications

Our largest system is ideal for light to heavy workpieces due to its high resilience and rigidity. The solid clamping devices also keep large components in shape and prevent distortion when welding the individual assemblies.

Recommended load up to 6000 kg*
 max. 2000 kg per leg basic equipment
 max. 3000 kg per leg basic equipment PLUS



Available table series:

- Basic (X8,7) Basic (750)
- Professional (750)
- Extreme (X8,7) Extreme (X8,8) PLUS

Boring Grid:



www.siegmund.com/F-tables

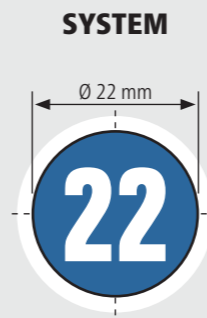

General Purpose Fabrication

We recommend our System 22 for fine details to medium-heavy fabrications. For everyone who cannot decide.

Recommended load up to 3000 kg*
 max. 1500 kg per leg basic equipment



Available table series:

- Professional (750)
- Extreme (X8,7) Extreme (X8,7) PLUS

Boring Grid:

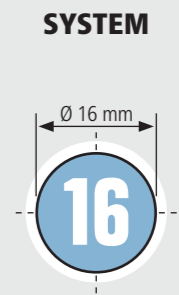

Fine Details Fabrication

Our System 16 is the right decision for fine details fabrications, such as railings or frame constructions.

Recommended load up to 2000 kg*
 max. 1000 kg per leg basic equipment

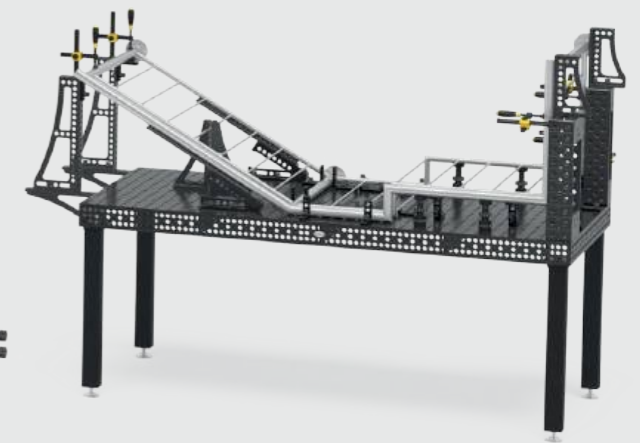

Available table series:

- Basic
- Professional (750)
- Extreme (X8,7) Extreme (X8,7) PLUS

Boring Grid:



UNIQUE WELDING TABLES FROM SIEGMUND

Proven 100.000 times worldwide

Our welding and clamping tables are characterized by the highest quality, resilience and precision. Not only welding work can be carried out on our tables, but also clamping and assembly work of all kinds with materials such as wood and plastic. We have invested a lot of development work in our welding tables in order to offer you a highly efficient working basis today.

- ✓ long lifetime
- ✓ unique materials
- ✓ high loads
- ✓ high precision and exact clamping
- ✓ same basis for all tasks
- ✓ high customer satisfaction

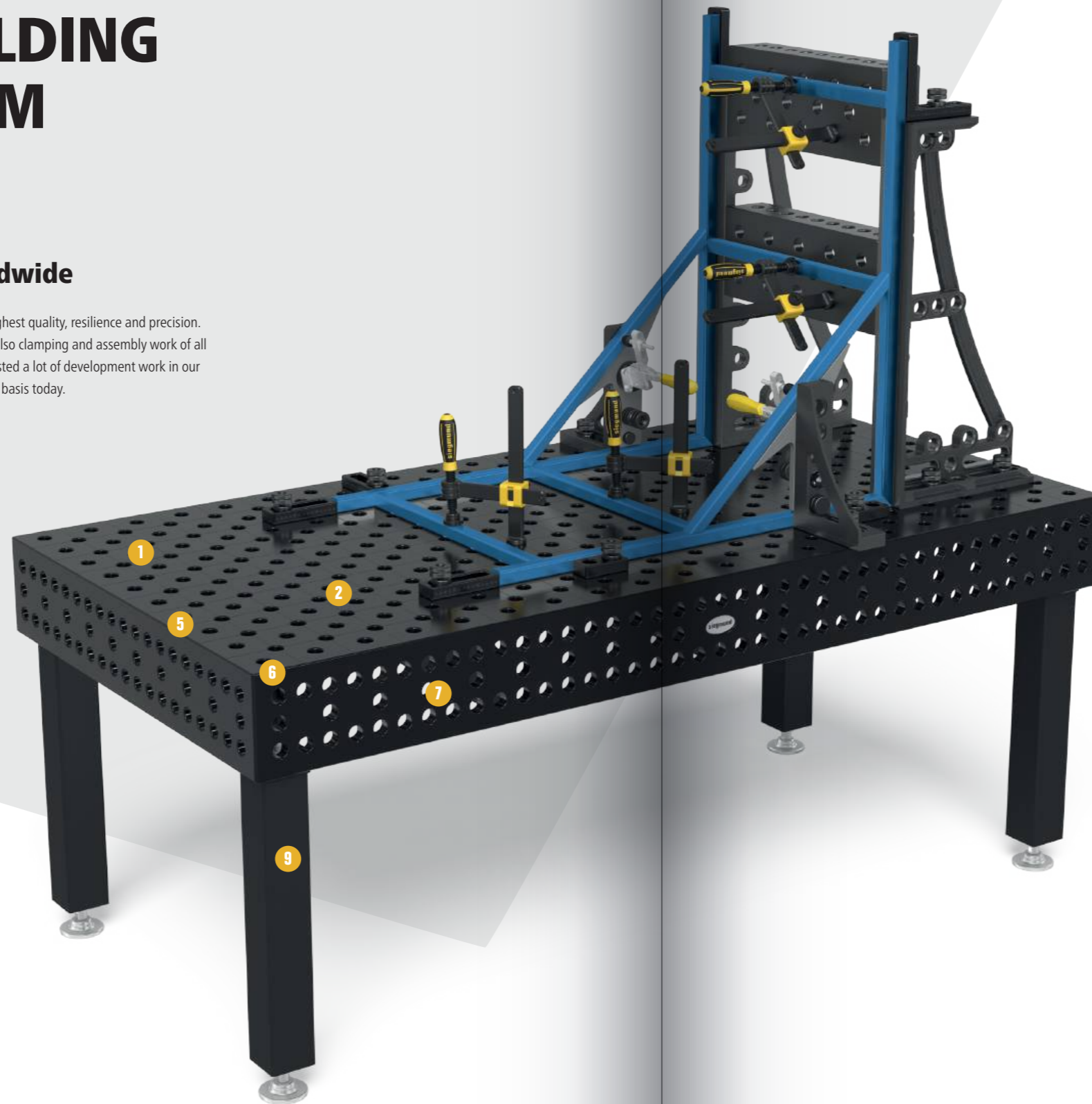

- 1 Unique materials developed by us**
Our material development has already received awards.
 - high basic hardness
 - improved nitriding results
 - improved dimensional stability
- 2 Surface**
 - precisely milled surface
 - reduced maintenance effort and improved corrosion protection through plasma nitriding
- 3 Radiused boreholes**
 - easier insertion of bolts and accessories
 - less adherence of welding spatters on bore edges
 - less damage to the borehole edges
- 4 Grid lines**
 - continuous lines for better orientation at a distance of 50 mm (System 16) or 100 mm (System 22 and 28)
 - enable precise clamping
- 5 Scale**
 - scaling on all four sides
 - saves time when clamping and setting up
- 6 Elaborate radiuses**
 - radiused edges and corners
 - reduce the risk of injury
 - protect components and accessories from getting damaged
- 7 Table side panel**
 - additional clamping surface
 - for extending and connecting tables
- 8 Ribbing**
 - for optimum stability and rigidity of the table top
 - for all table series and sizes
- 9 Stable table legs**
 - optimal pressure distribution
 - high strength ensures precision of the table surface
 - different versions available

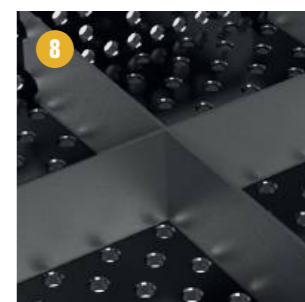
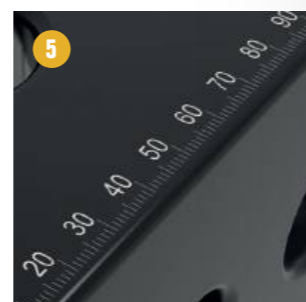
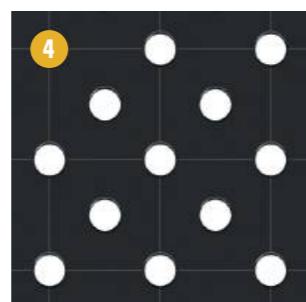
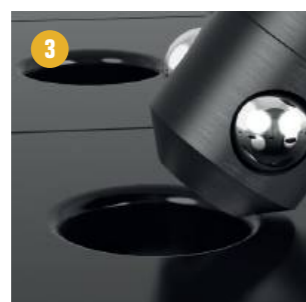
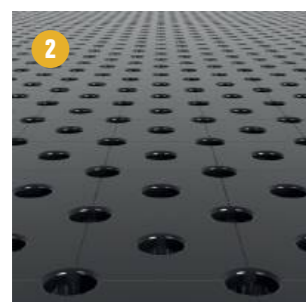



Basic 750 / Basic 8.7

- high quality steel S355J2+N or tool steel X8.7
- plasma nitrided and BAR coated
- for simple work
- System 16 with normal grid, System 28 with normal grid or diagonal grid
- no or shortened table side panel



Professional 750

- premium steel S355J2+N
- plasma nitrided and BAR coated
- Standard version with normal grid
- System 22 and 28 with diagonal grid as a special version
- Table side panel with two rows of boreholes



Extreme 8.7

- Through-hardened tool steel X8.7
- plasma nitrided and BAR coated
- significantly higher basic hardness
- highest precision even after use
- for demanding work
- System 16 with normal grid, system 22 and 28 with diagonal grid
- Table side panel made of steel S355J2+N
- System 16 and 28 with additional row of boreholes in the table side panel



TABLE SERIES AT A GLANCE

With our table series, we provide a suitable working basis for every challenge and every requirement. Choose from three different materials.



www.siegmund.com/F-hardness



Extreme 8.7 PLUS

- Through-hardened tool steel X8.7
- plasma nitrided and BAR coated
- significantly higher basic hardness
- highest precision even after use
- for particularly demanding work
- System 16 with normal grid, System 22 with diagonal grid
- Table side panel made of steel S355J2+N
- improved rigidity of the table top thanks to extra high side panels and ribbing



Extreme 8.8 PLUS

- Through-hardened tool steel X8.8
- plasma nitrided and BAR coated
- extremely high basic hardness
- maximum resistance to impact
- highest precision even after use
- for extraordinarily demanding work
- System 28 with diagonal grid
- Table side panel made of steel S355J2+N
- improved rigidity of the table top thanks to extra high side panels and ribbing



MATERIALS

With our evaluation, we would like to make it easier for you to compare the different materials and to support you in selecting the right welding table.

	750 Steel S355J2+N (without Plasma nitration)	750 Steel S355J2+N (with Plasma nitration)	X8.7 Tool Steel X8.7	X8.8 Tool Steel X8.8
Basic hardness	★★	★★	★★★★★★	★★★★★★
Surface hardness	★★	★★★★★★	★★★★★★	★★★★★★
Impact-proof	★★	★★★	★★★★★★	★★★★★★
Scratch-proof	★★	★★★★	★★★★★★	★★★★★★
Protection against weld spatter	★	★★★★★★	★★★★★★	★★★★★★
Corrosion resistance	★	★★★★★★	★★★★★★	★★★★★★
Point load	★★★	★★★★	★★★★★★	★★★★★★
Flatness in its new state	★★★★★★	★★★★★★	★★★★★★	★★★★★★
Maintenance of the flatness under heavy use	★	★★★	★★★★	★★★★
Life span	★★	★★★★	★★★★	★★★★

Basic hardness

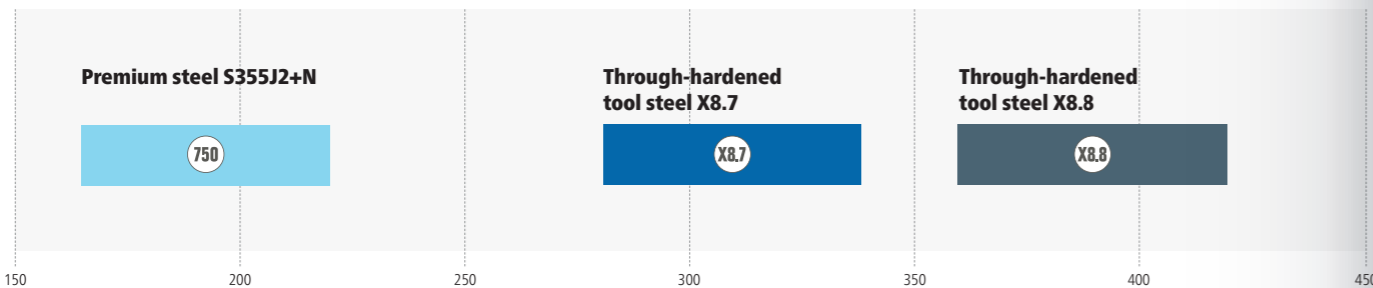

Surface hardness

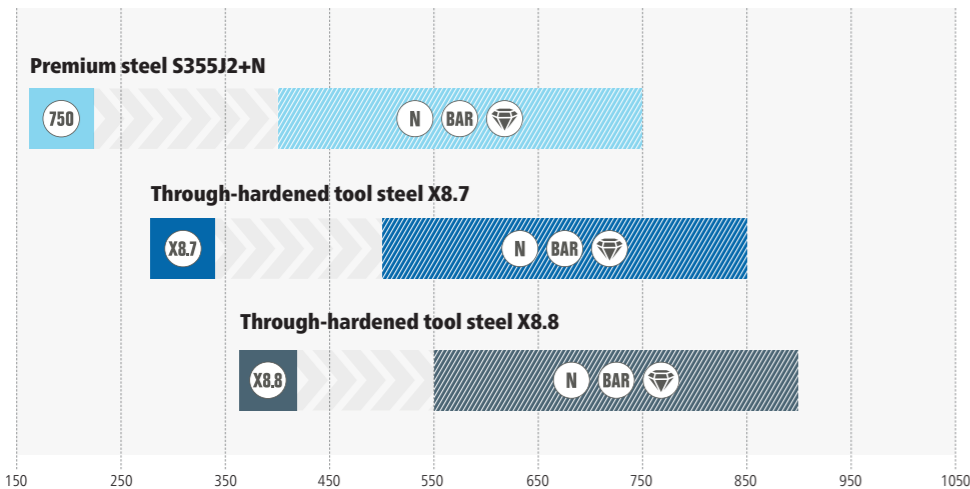

A high basic hardness is crucial for high impact resistance and the long service life of a welding table. The subsequent plasma nitration and BAR coating results in a surface refinement that hardens the material and protects it from scratches, corrosion and weld spatter adhesion. Only the combination of high basic hardness and plasma nitriding results in a low-wear and durable surface.

Approximate Vickers Hardness

PLASMA NITRATION

Proven surface finish

Siegmund's welding tables have been plasma nitrided as standard since 2009. With years of experience and ongoing process optimization, we have developed a welding table that stands out for its robustness and durability, making it nearly unmatched by other products.

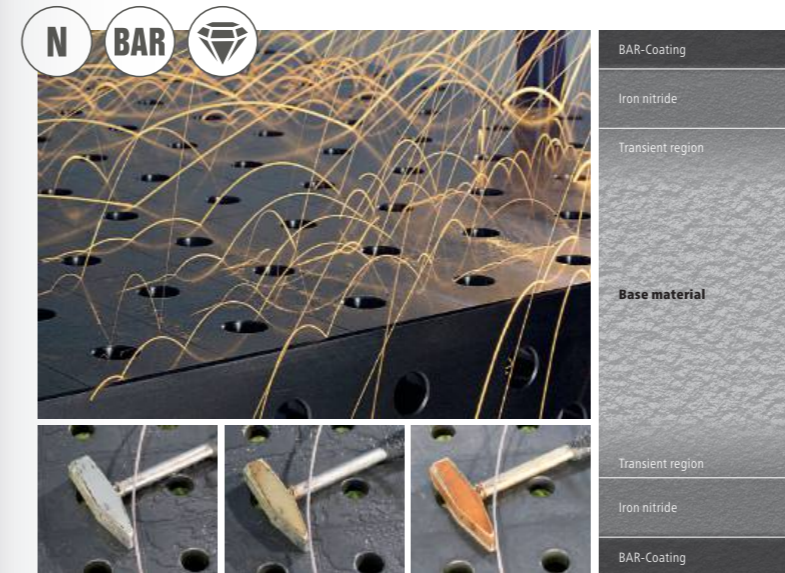

What is plasma nitration?

Plasma nitriding is a thermochemical diffusion process for surface layer hardening. The surface layer of a workpiece or component is enriched with nitrogen, which forms a wear and corrosion protection layer on the component surface and in the area close to the surface. The manufacturing process takes place under vacuum at around 500 degrees Celsius. In conjunction with additional production steps, we achieve a nearly distortion-free product.

Plasma nitriding is one of the most environmentally friendly hardening processes because only nitrogen, hydrogen and oxygen are required for the hardening process. These gases are the main components of the air. At Siegmund, the required energy is provided exclusively electrically, instead of the fossil fuels that are otherwise customary on the market for heating the components.

- ✓ Durable high wear resistant surfaces
- ✓ Scratch resistant
- ✓ Corrosion resistant
- ✓ Significantly less welding spatter adhesion

BAR-Coating

Unique to Siegmund is the subsequent BAR coating of the welding tables and many tool parts, which takes place after plasma nitriding. The BAR coating (Black-Anti-Rust Coating) additionally planes the surface and increases protection against rust.

- ✓ Reinforced rust protection
- ✓ Additional grading of the surfaces



www.siegmund.com/
F-plasma

OUR WELDING TABLES IN ACTION: FROM RAILING CONSTRUCTION TO A STARSHIP

As the largest welding table manufacturer in the world, we can draw on the wealth of experience of many international customers. Discover more than 200 practical examples directly from our customers' workshops on our website and benefit from the versatile application possibilities of our welding tables.



[www.siegmund.com/
F-practice](http://www.siegmund.com/F-practice)



Our products for industry and craftsmanship



Automation



Machine tools and
plant construction



Steel and metal
construction



Vehicle
construction



Shipbuilding



Aircraft construction



Agriculture



Stage technology

JARA MASCHINENBAU

Emsland (DE)



Machine tools and
plant construction

JARA Maschinenbau GmbH is a medium-sized company based in the Emsland region of Germany. Its core competencies include special-purpose machinery construction, customized lifting platforms, and specialized drilling systems.

The images show a formwork element that is part of a wind turbine formwork. Thanks to Siegmund's modular table system, fixtures can be precisely configured quickly and with little effort, even for the production of large components.



MHC GMBH

Beelen (DE)



At MHC, we rely on Siegmund products because they stand for the highest quality and precision. Siegmund's innovative welding tables and workbenches enable us to develop customized solutions for our customers while working efficiently and reliably. The modular design and diverse accessories give us the flexibility to master any challenge.



RUFFIAN CARS

Santa Ana, California (USA)



Ruffian stands for uncompromising craftsmanship and pure performance in pro-touring style. When classic muscle cars from the '60s and '70s meet modern supercar technology, Ruffian creates truly unique pieces – built with precision, passion, and style.

To ensure maximum accuracy in their custom builds, Ruffian relies on welding tables and clamping systems from Siegmund.

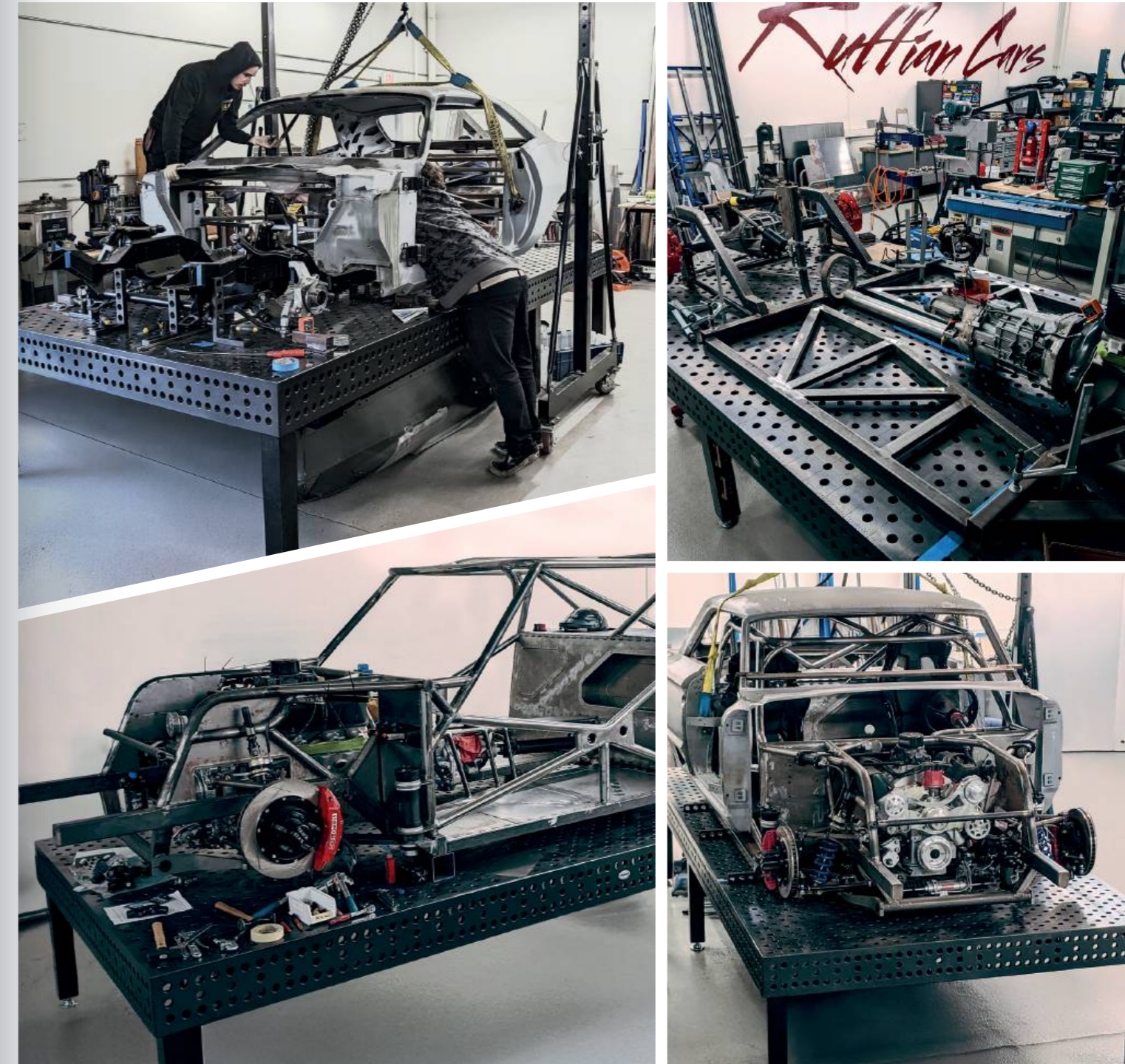

HAMLIN WELDING

Melbourne, Florida (USA)



Steel and metal construction

Hamlin Welding And Fabricating LLC in Florida specializes in custom-made furniture, sculptures, and various products for upscale residential construction. The versatility of Siegmund products and the high variability in the production of devices enable a fast, time-saving and precise production process.

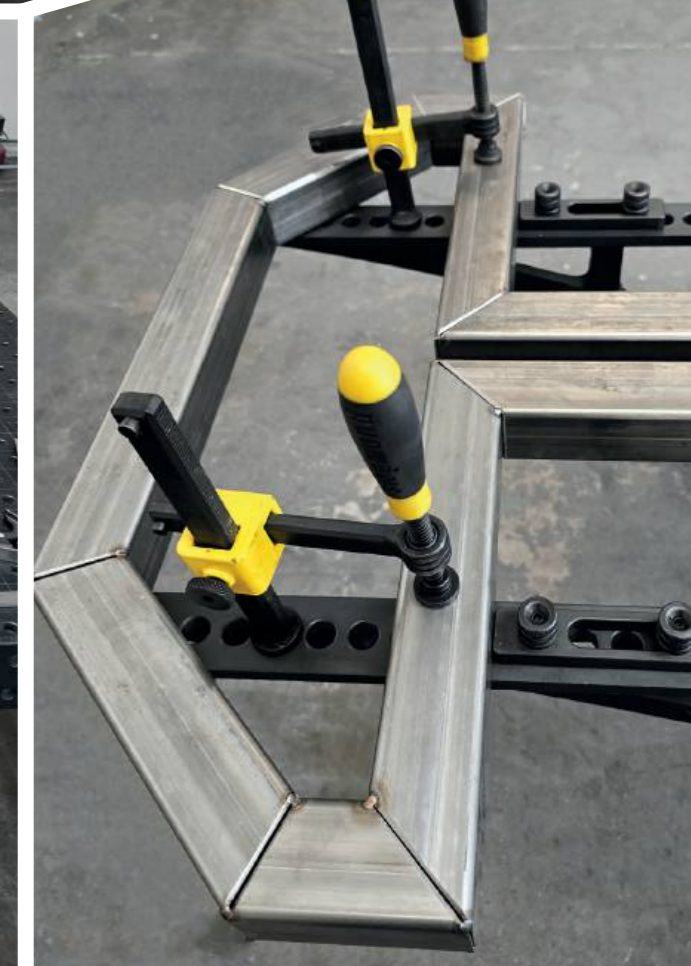
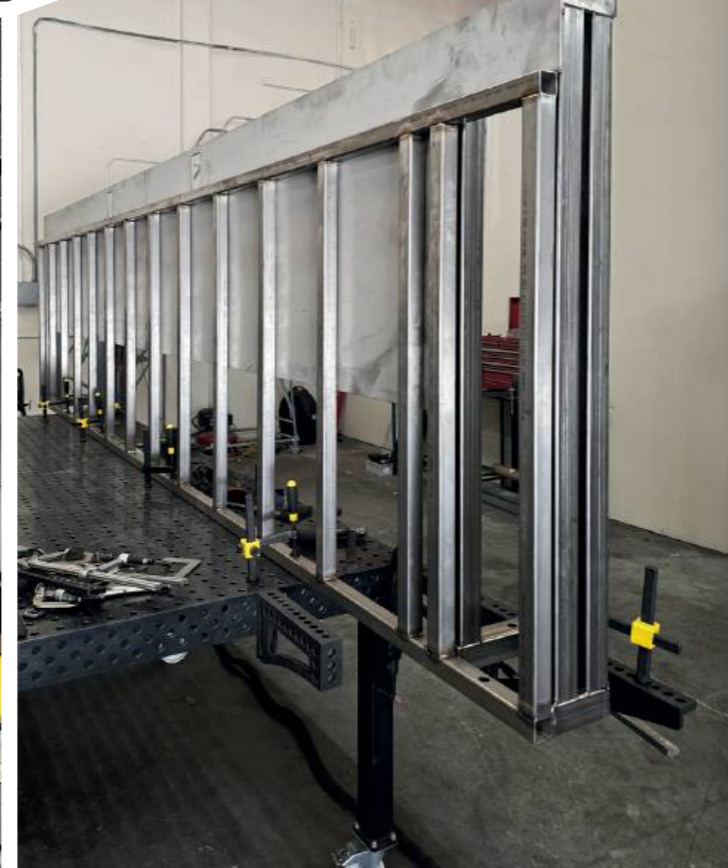
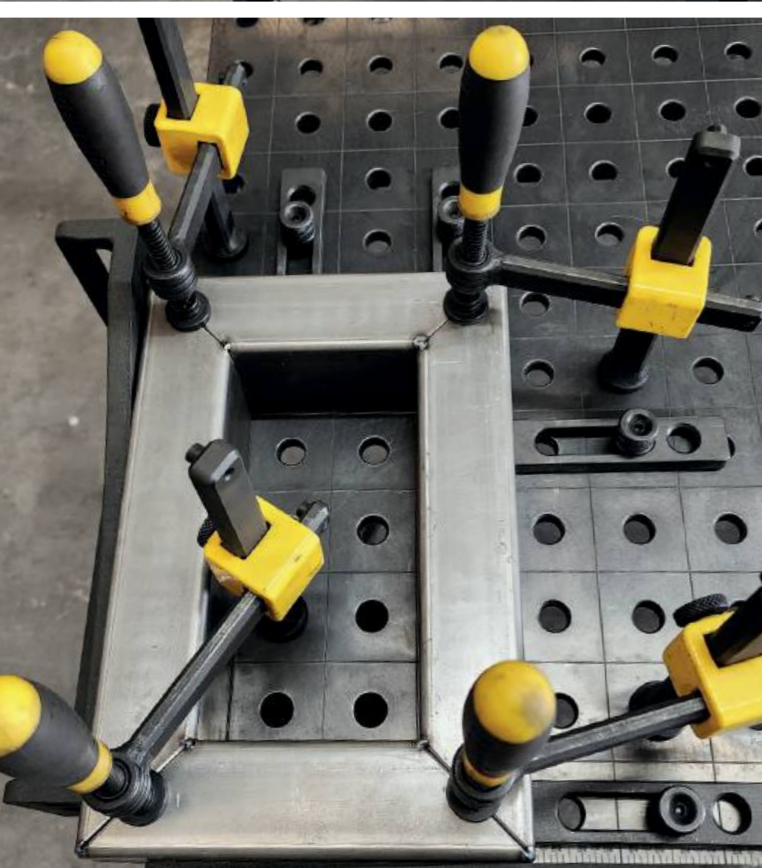

SUVI OÜ

Tartu (EE)



SUVI Performance stands for highest quality and individualization of motorsport products. Whether individual components or entire chassis – the production of special parts requires a high degree of variability and precision in clamping the individual parts. With our Professional Extreme 8.8 PLUS and accessories consisting of clamps, bolts and squares, projects can be implemented quickly without much rework.

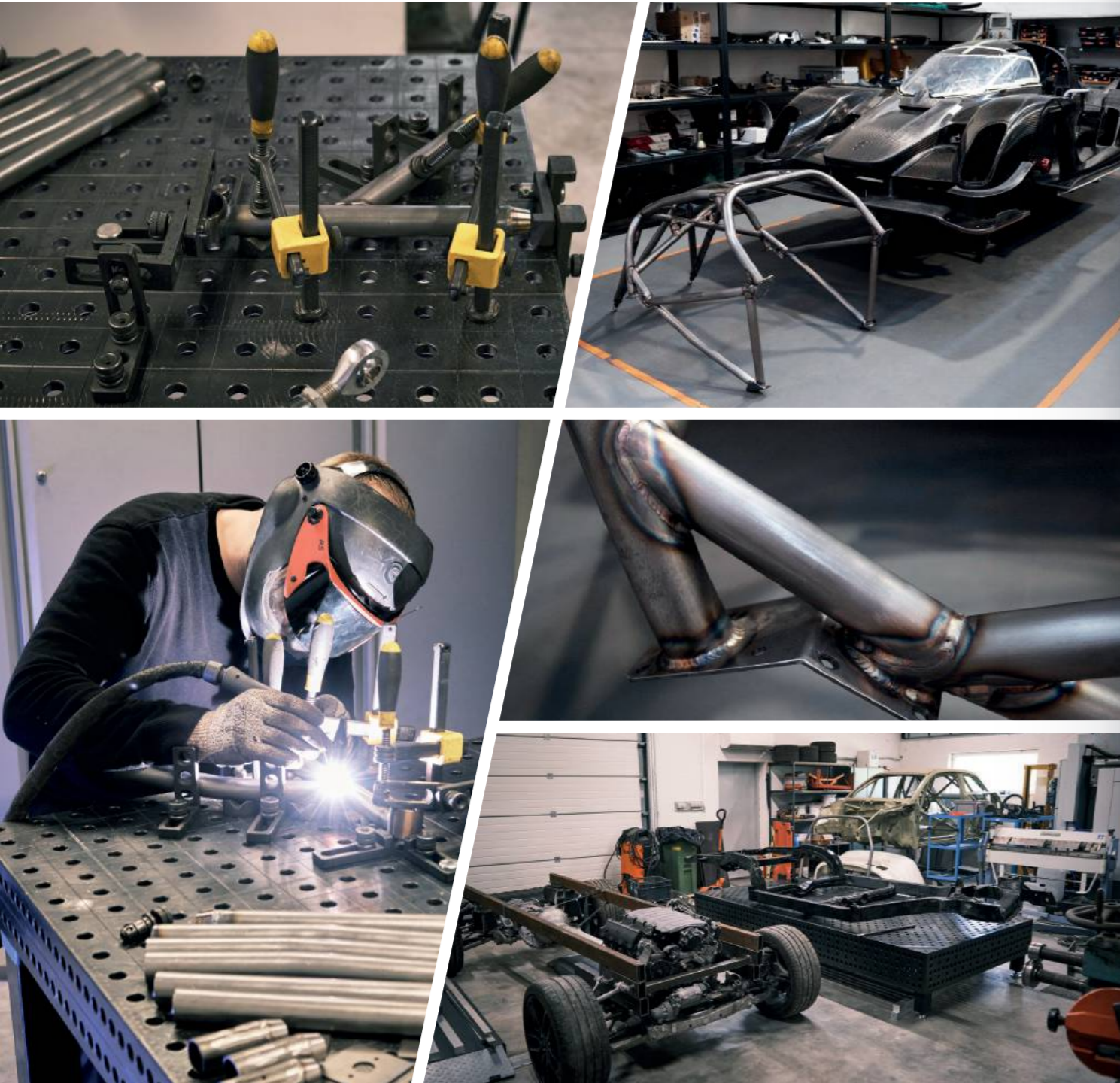

BAILEY BUILT WHEELCHAIRS

Wildomar, California (USA)



The wheelchairs of Bailey Built Wheelchairs make everyday life easier for people with limited mobility. Daily challenges such as uneven terrain can be easily mastered with the manual or automatic wheelchairs. In order to be able to implement the special requirements of the customers in a dimensionally accurate way, Bailey Built Wheelchairs relies on our Siegmund welding tables and accessories, which enable a fast and precise work application.



NEW THE PROFESSIONAL WORKBENCH FROM SIEGMUND

robust, versatile and well thought out



Equip your workshop now with a complete package

Whether sawing, screwing, or assembling, the high-quality Siegmund workbench offers you the stable and durable work surface you need for precise and safe work. Versatile in use for wood and metalworking, repairs, or creative projects, it's the ideal foundation for efficient work and professional results. Rely on quality when it matters most.

The Siegmund workbench adapts to your needs: Choose between plasma-nitrided steel plates or lightweight aluminum plates and complement them with our MDF protective plates. Thanks to the modular system, the workbench can be flexibly expanded – for example, with drawers, extension tables for machines, or work surface extensions.



More than just a workbench!

- ✔ versatile for metalworking, wood constructions or repairs
- ✔ stable and durable work surface for precise work
- ✔ various high-quality worktops to choose from
- ✔ modularly expandable with drawers or extension tables
- ✔ ergonomic working thanks to height-adjustable legs
- ✔ individually configurable for any workshop size
- ✔ perfect combination of functionality and design

from 760 €

Watch the video now:



www.siegmund.com/workbench-video



reddot winner 2024



Discover more products online or in our flyer!

www.siegmund.com/workbench-flyer

WORLD OF WORKSTATION

With the Siegmund Workstation you get a low-cost workplace in a small area with plenty of storage space in the usual Siegmund quality. All the accessories are compatible with the Workstation's perforated plates, allowing you to carry out all kinds of welding, clamping or assembly work on them. Regardless of whether you work with wood or build and weld metal constructions, the Workstation is as versatile as your ideas and tasks.

- ✓ precise work surface
- ✓ sturdy frame
- ✓ stable drawers
- ✓ versatile
- ✓ individually configurable
- ✓ different sizes
- ✓ Organization and storage space



Workstation 0806
Working surface 800x600 mm



Workstation 1208
Working surface 1200x800 mm

The essential component of every workbench – the worktop

A work plate has to withstand high loads. We have special work plates for you, according to your needs – whether sawing, drilling, welding, clamping etc. Depending on the version, the perforated plates are made of steel S355J2+N or tool steel X8.7, and are plasma nitrided and BAR-coated.



056 108 146



[www.siegmund.com/
F-workstation](http://www.siegmund.com/F-workstation)



Workstation 1212
Working surface 1200x1200 mm

The base – a sturdy frame

The sturdy frame offers a solid base for the most challenging tasks such as sawing, grinding or drilling.



RAIL SYSTEM STANDARD

With our standard rail system, there is just one connecting frame with the same track width, regardless of the chosen table size.

- ✔ uniform track width
- ✔ 3 table sizes
- ✔ 1 connecting frame in two working heights
- ✔ Hardened and rust-protected rails
- ✔ effortless positioning on the rail
- ✔ can be delivered quickly as all items are in stock as standard
- ✔ Above-floor and underfloor installation possible
- ✔ structured workspace with many clamping options



[www.siegmund.com/
F-railsystem](http://www.siegmund.com/F-railsystem)

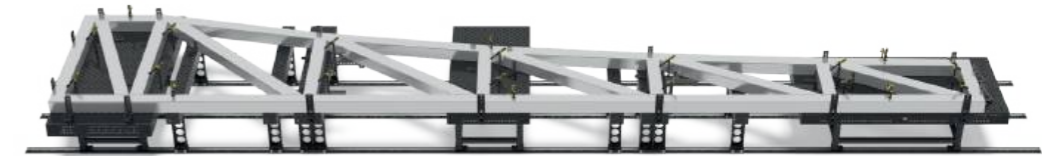

Hardened and rust-protected rails

The foundation rails with integrated round rail are made of high-quality steel S355J2+N and then plasma nitrided. This process not only gives the rails exceptional hardness and durability, but also reliably protects them against rust.

NEW THE MODULAR LASER WELDING CELL

Maximum safety and easy commissioning

Manual laser welding has quickly established itself as an indispensable process in welding technology. In order to meet the increased safety requirements, Siegmund introduced a laser welding cell as a protective enclosure in 2023. With the launch of a completely new, innovative and modular generation of laser welding cells, we are setting new standards in terms of safety and flexibility.

The Siegmund laser welding cell provides optimal protection against scattered radiation and reflections that can occur when working with lasers. With its innovative design and pre-assembled side walls, it is quickly ready for use. It is suitable for manual laser welding and laser cleaning in the wavelength range from 940 to 1090 nm.



www.siegmund.com/lasercell

Siegmund Laser welding cell

from 4.776 €



Discover more products online or in our flyer!

www.siegmund.com/lasercell-flyer



Pre-assembled side walls according to DIN EN 60825-4

- ✓ Aluminum composite panels (Color: RAL 9006, B1 certified)
- ✓ approved for a maximum laser power of 3 kW
- ✓ certified according to DIN EN 60825-4
- ✓ Wall thickness 4 mm
- ✓ with passive ventilation opening
- ✓ expandable anytime

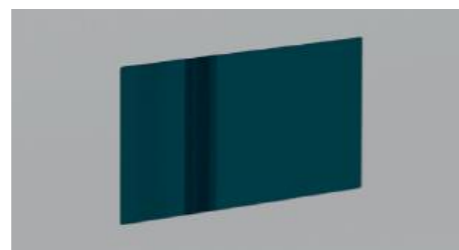

Certified laser protection window

- ✓ optimal eye protection when looking into the cell
- ✓ good visibility inside and out
- ✓ Window thickness 3 mm
- ✓ made of high-quality polycarbonate
- ✓ certified according to DIN EN 60825-4 and DIN EN 207



Our recommendation: Closed roof

- ✓ connection available for fume extraction system (Ø 200 mm)
- ✓ Aluminum composite panels (Color: RAL 9006, B1 certified)
- ✓ Wall thickness 4 mm
- ✓ certified according to DIN EN 60825-4
- ✓ upgrading possible at any time



Optional safety package

- ✓ Safety switch for monitoring and actively locking the door
- ✓ Display signal for laser operation
- ✓ Emergency stop switch
- ✓ Integration of lasers from all manufacturers
- ✓ upgrading possible at any time

PERFECT INTERACTION FOR YOUR SERIES PRODUCTION



Siegmund Welding Cell

- ✔ configured and expanded for each specific application
- ✔ compatible with all types of robots and cobots
- ✔ exclusive Siegmund cell design
- ✔ low initial costs and high efficiency
- ✔ compact design
- ✔ high security standard
- ✔ quick start-up



[www.siegmund.com/
F-cell](http://www.siegmund.com/F-cell)



reddot winner 2023
industrial design



Zero point clamping system

- ✔ Maximum vertical holding force 2 kN per module
- ✔ Zeroing with high precision
- ✔ Switch quickly between reused fixtures
- ✔ Minimization of non-productive welding times
- ✔ Suitable for use with and without welding robots
- ✔ High repeatable accuracy



[www.siegmund.com/
F-zero-point](http://www.siegmund.com/F-zero-point)



mechanical



pneumatic

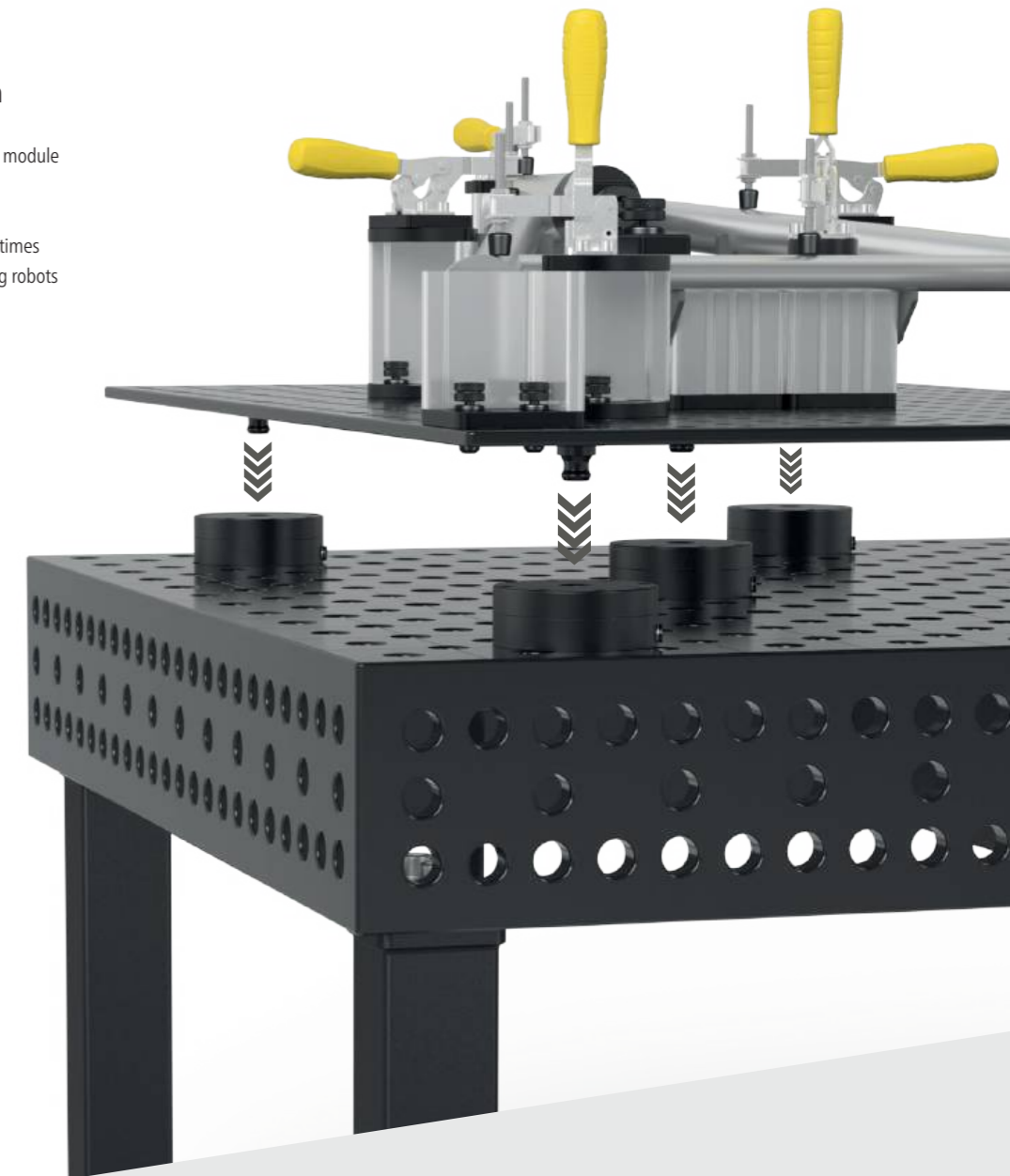

Clamping system

- ✔ Build fixtures yourself
- ✔ Easy combination with templates
- ✔ Modular system for maximum flexibility
- ✔ Profiles available in fixed lengths and as mass product



[www.siegmund.com/
F-clampingsystem](http://www.siegmund.com/F-clampingsystem)



SMALL REQUIRED SPACE, BIG IMPACT

Siegmund clamping claws: Our recommendation for robot welding

The clamping claws are characterized by their flexible clamping range, which allows workpieces of different sizes to be fixed easily and securely. They are also suitable for clamping flat structures. Thanks to their small interference contour, they create ideal working conditions, especially when used in automation and when using robots.

- ✔ low interference contour
- ✔ recommended for robot welding
- ✔ flexible clamping range
- ✔ reliable and precise fixation of workpieces
- ✔ quick and easy operation
- ✔ ideal for flat components

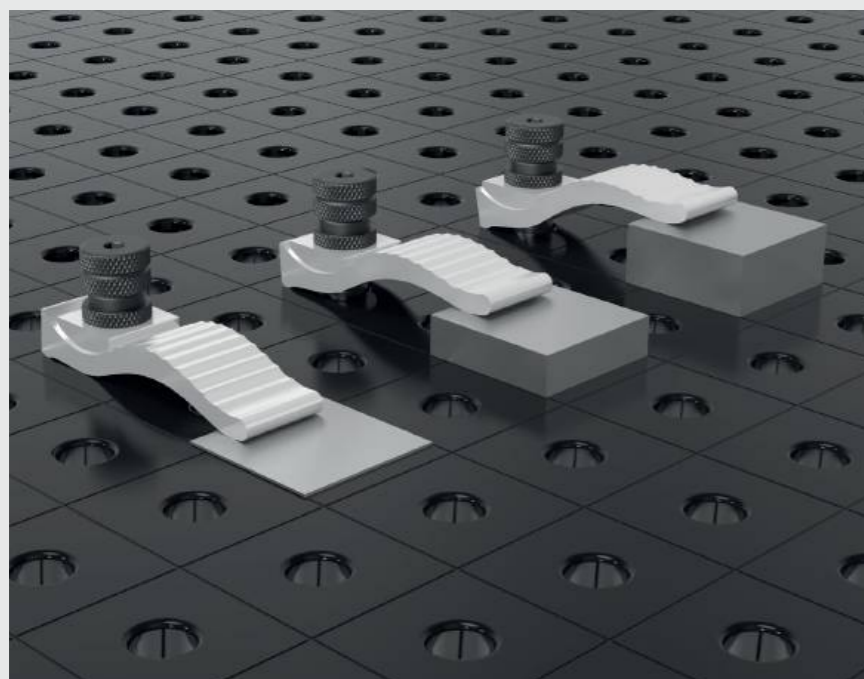

Siegmund clamping claws:
Ideal conditions in automation
thanks to low interference
contour



[www.siegmund.com/
F-clampingsystem](http://www.siegmund.com/F-clampingsystem)

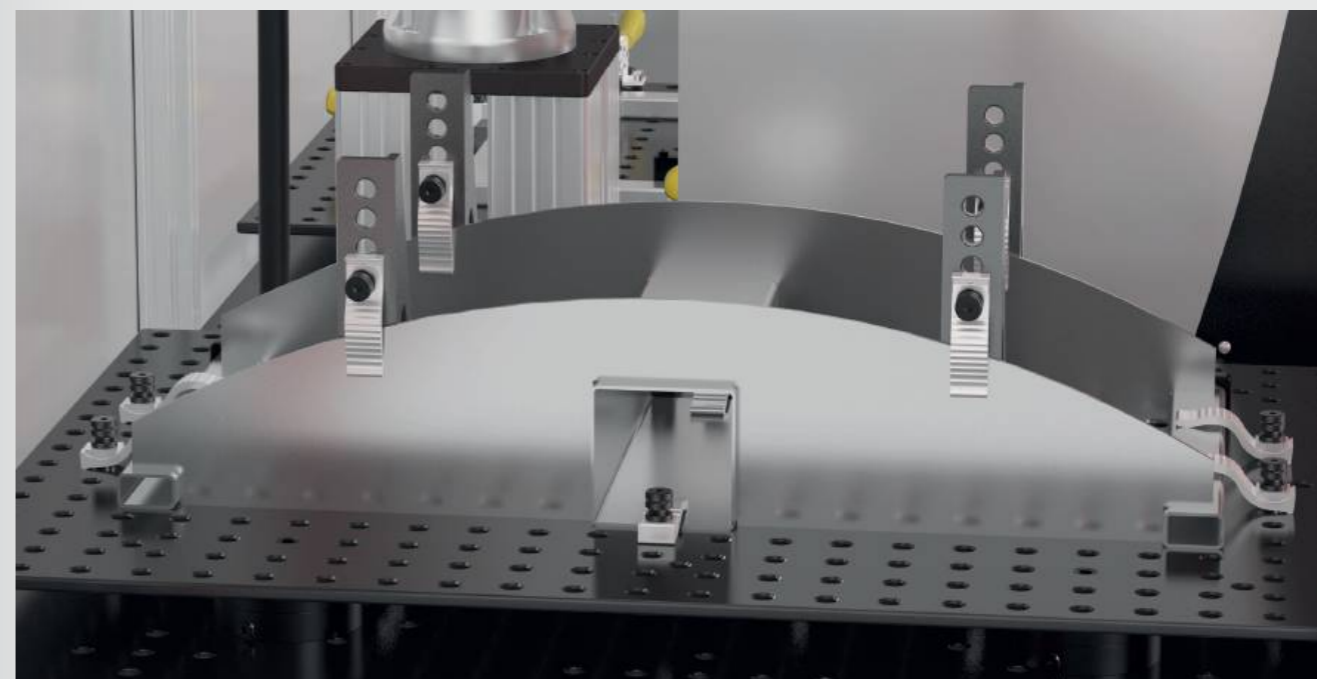

LIGHT TO HEAVY DUTY FABRICATIONS

Our largest system is ideal for light to heavy workpieces due to its high resilience and rigidity. The solid clamping devices also keep large components in shape and prevent distortion when welding the individual assemblies.

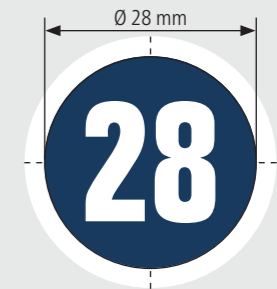

Recommended load up to 6000 kg

max. 2000 kg per leg basic equipment
max. 3000 kg per leg basic equipment PLUS

Basic 750

- premium steel S355J2+N
- Material thickness approx. 24,5 – 27 mm
- Borehole Ø 28 mm, Boreholes on the surface 100x100 mm grid
- M12-thread on 4 sides every 200 mm
- incl. leg standard equipment



Table size	Legs	Weight			
1200 x 1200 mm	4	354 kg	1.537 £	4-281015	•
1500 x 1000 mm	4	370 kg	1.558 £	4-281035	•
2000 x 1000 mm	4	475 kg	2.001 £	4-281020	•
2000 x 1200 mm	4	569 kg	2.264 £	4-281060	•
2400 x 1200 mm	6	697 kg	2.547 £	4-281030	•
3000 x 1500 mm	6	1043 kg	3.520 £	4-281040	•



Weight = Table Top + Pallet + Leg standard equipment
 Maximum recommended static total load with 4 legs 2000 kg based on even load distribution. (Data only for leg standard equipment)
 Without Plasma nitration: Unprotected against rust, scratches and welding spatters. Protection against welding spatters is only given by using anti-spatter spray.



www.siegmund.com/
F-tablebasic75028

Table Legs



	Standard equipment	Height adjustable	Caster, locking brake	Height adjustable, caster, locking brake	Floor anchoring
	161856	4-160877.1.XX	4-161855.XX	4-160879.XX	4-160874.XX
Capacity per table leg	1000 kg	1000 kg	500 kg	500 kg	1000 kg
Leg height	815 mm	550 – 950 mm	815 mm	600 – 900 mm	815 mm
Fine adjustment	50 mm	40 mm	30 mm	30 mm	50 mm
Surcharge per leg	included	61 £	68 £	101 £	58 £

Working height = height of table leg + height of side panel of table
 The specified load capacities refer to static load. Note: Not recommended for welding tables with 6 table legs. Because of risk of tipping not permitted for 1200x800 mm tables.

Basic sets



	280604	280511	280420.N	280110.N	280162.N
1	4-281200	4x	8x	6x	2x
2	4-281300	8x	12x	8x	4x
3	4-281400	10x	18x	10x	6x

Basic 8.7

- Through-hardened tool steel X8.7, plasma nitrided and BAR-coated
- Material thickness approx. 24,5 – 27 mm
- Borehole Ø 28 mm, Boreholes on the surface in diagonal grid
- M12-thread on 4 sides every 200 mm
- incl. leg standard equipment



Table size	Legs	Weight			
1000 x 1000 mm	4	236 kg	1.518 £	4-281010.XD7	•
1200 x 800 mm	4	229 kg	1.511 £	4-281025.XD7	•
1200 x 1200 mm	4	325 kg	1.836 £	4-281015.XD7	•
1500 x 1000 mm	4	340 kg	1.848 £	4-281035.XD7	•
2000 x 1000 mm	5	442 kg	2.386 £	4-281020.XD7	•
2000 x 1200 mm	5	527 kg	2.702 £	4-281060.XD7	•
2400 x 1200 mm	6	636 kg	3.053 £	4-281030.XD7	•
3000 x 1500 mm	6	948 kg	4.230 £	4-281040.XD7	•



Weight = Table Top + Pallet + Leg standard equipment
 Maximum recommended static total load with 4 legs 2000 kg based on even load distribution. (Data only for leg standard equipment)



www.siegmund.com/
F-tablebasicX728

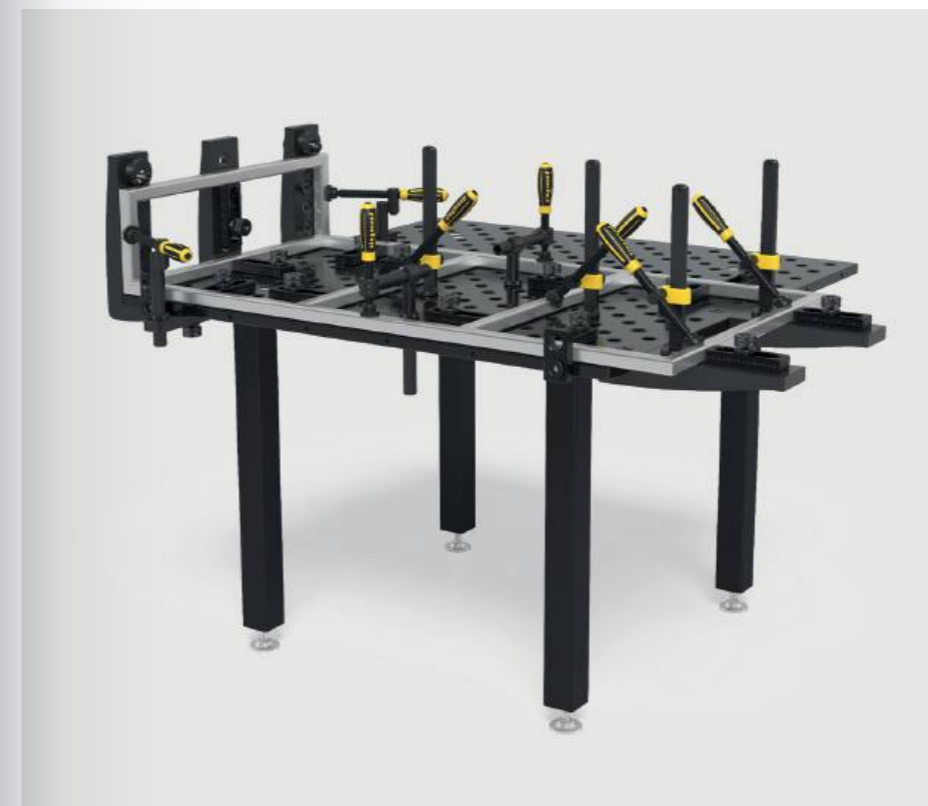

	280543	160415	284050.Set	283999	
	8x	8x		1x	1.264 £ •
	8x	8x	2x	1x	1.909 £ •
	8x	8x	4x	1x	3.377 £ •

Professional 750

- premium steel S355J2+N, plasma nitrided and BAR-coated
- Material thickness approx. 24,5 – 27 mm
- Borehole Ø 28 mm, Boreholes on the surface 100x100 mm grid
- Height of table side 200 mm, Borehole spacing of table side 50 mm
- incl. leg standard equipment



Table size	Legs	Weight			
1000 x 1000 mm	4	416 kg	2.552 £	4-280010.P	•
1200 x 800 mm	4	408 kg	2.545 £	4-280025.P	•
1200 x 1200 mm	4	544 kg	3.450 £	4-280015.P	•
1500 x 1000 mm	4	577 kg	3.547 £	4-280035.P	•
1500 x 1500 mm	4	801 kg	4.716 £	4-280050.P	•
2000 x 1000 mm	4	730 kg	4.204 £	4-280020.P	•
2000 x 1200 mm	4	843 kg	4.812 £	4-280060.P	•
2000 x 2000 mm	4	1299 kg	7.438 £	4-280045.P	•
2400 x 1200 mm	4	986 kg	5.416 £	4-280030.P	•
3000 x 1500 mm	6	1517 kg	7.944 £	4-280040.P	•
4000 x 2000 mm	8	2501 kg	12.091 £	4-280055.P	•

Weight = Table Top + Pallet + Leg standard equipment
 Maximum recommended static total load with 4 legs 4000 kg based on even load distribution. (Data only for leg standard equipment)
 All tables are available on order without plasma nitriding or with a diagonal grid: www.siegmund.com/F-table75028



www.siegmund.com/F-table75028

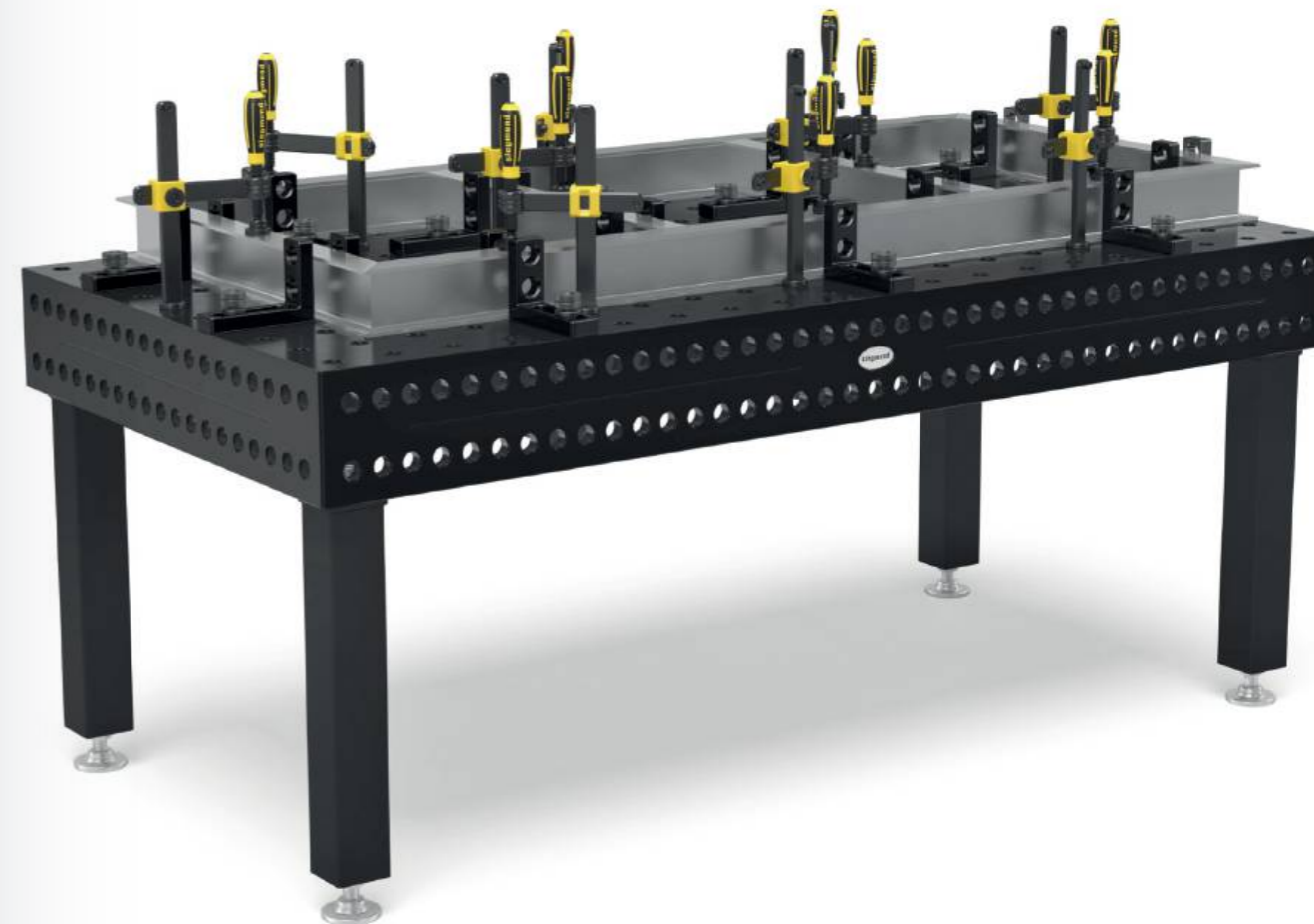

Table Legs



	Standard equipment	Standard equipment	Height adjustable	Height adjustable	Caster, locking brake	Height adjustable, caster, locking brake	Floor anchoring	Floor anchoring
	280858.X	280857.X	4-280878.1.XX	4-280877.1.XX	4-280876.XX	4-280879.XX	4-280874.XX	4-280875.XX
Capacity per table leg	2000 kg	2000 kg	2000 kg	2000 kg	1500 kg	1500 kg	2000 kg	2000 kg
Leg height	650 mm	750 mm	450 – 700 mm	550 – 900 mm	650 mm	550 – 750 mm	650 mm	750 mm
Fine adjustment	50 mm	50 mm	50 mm	50 mm	20 mm	20 mm	50 mm	50 mm
Surcharge per leg	included	Alternatively	86 £	88 £	111 £	144 £	58 £	58 £

Working height = height of table leg + height of side panel of table
 The specified load capacities refer to static load. Note castor: Not recommended for welding tables with 6 or 8 table legs.

Sets



		280610.N	280630.N	280648.1.N	280511	280740	280410.N	280420.N	280430.N
1	4-283100	4x	2x	2x	12x		4x	4x	
2	4-283200	6x	4x	4x	18x	4x	6x	6x	
3	4-283300	10x	6x	4x	24x	4x	8x	8x	
4	4-283400	14x	10x	6x	30x	8x	10x	10x	4x
5	4-283500	14x	10x	8x	36x	8x	12x	12x	4x



	280110.N	280152.N	280162.N	280164+65.N	280166+67.N	280144+46.N	280910	283999	
	2x	2x						1x	2.026 £ •
	4x	2x	2x					1x	3.575 £ •
	6x	2x	2x		1x			1x	5.159 £ •
	8x	2x	2x	1x	1x		1x	1x	8.115 £ •
	12x	2x	2x	1x	1x	1x	1x	1x	9.898 £ •

Professional Extreme 8.7

- Through-hardened tool steel X8.7, plasma nitrided and BAR-coated
- Material thickness approx. 24,5 – 27 mm
- Borehole Ø 28 mm, Boreholes on the surface in diagonal grid
- Height of table side 200 mm, Boreholes on table sides in diagonal grid
- Table side panel made of high quality steel S355J2+N
- incl. leg standard equipment



Table size	Legs	Weight			
1000 x 1000 mm	4	400 kg	3.187 £	4-280010.XD7D	•
1200 x 800 mm	4	392 kg	3.179 £	4-280025.XD7D	•
1200 x 1200 mm	4	521 kg	4.072 £	4-280015.XD7D	•
1500 x 1000 mm	4	554 kg	4.379 £	4-280035.XD7D	•
1500 x 1500 mm	4	767 kg	5.753 £	4-280050.XD7D	•
2000 x 1000 mm	4	699 kg	5.195 £	4-280020.XD7D	•
2000 x 1200 mm	4	806 kg	5.863 £	4-280060.XD7D	•
2000 x 2000 mm	4	1240 kg	8.950 £	4-280045.XD7D	•
2400 x 1200 mm	4	947 kg	6.642 £	4-280030.XD7D	•
3000 x 1500 mm	6	1425 kg	9.531 £	4-280040.XD7D	•
4000 x 2000 mm	8	2384 kg	14.807 £	4-280055.XD7D	•
4800 x 2400 mm	11	3275 kg	21.361 £	4-280065.XD7D	○



www.siegmund.com/
F-tableX728

Weight = Table Top + Pallet + Leg standard equipment
Maximum recommended static total load with 4 legs: 4000 kg based on even load distribution. (Data only for leg standard equipment)
All tables are available on order without plasma nitriding or with a 100x100 mm grid: www.siegmund.com/F-tableX728

Table Legs



	Standard equipment	Standard equipment	Height adjustable	Height adjustable	Caster, locking brake	Height adjustable, caster, locking brake	Floor anchoring	Floor anchoring
	280858.X	280857.X	4-280878.1.XX	4-280877.1.XX	4-280876.XX	4-280879.XX	4-280874.XX	4-280875.XX
Capacity per table leg	2000 kg	2000 kg	2000 kg	2000 kg	1500 kg	1500 kg	2000 kg	2000 kg
Leg height	650 mm	750 mm	450 – 700 mm	550 – 900 mm	650 mm	550 – 750 mm	650 mm	750 mm
Fine adjustment	50 mm	50 mm	50 mm	50 mm	20 mm	20 mm	50 mm	50 mm
Surcharge per leg	included	Alternatively	86 £	88 £	111 £	144 £	58 £	58 £

Working height = height of table leg + height of side panel of table
The specified load capacities refer to static load. Note: Not recommended for welding tables with 6 or 8 table legs.

Sets



		280610.N	280630.N	280648.1.N	280511	280740	280410.N	280420.N	280430.N
1	4-283100	4x	2x	2x	12x		4x	4x	
2	4-283200	6x	4x	4x	18x	4x	6x	6x	
3	4-283300	10x	6x	4x	24x	4x	8x	8x	
4	4-283400	14x	10x	6x	30x	8x	10x	10x	4x
5	4-283500	14x	10x	8x	36x	8x	12x	12x	4x

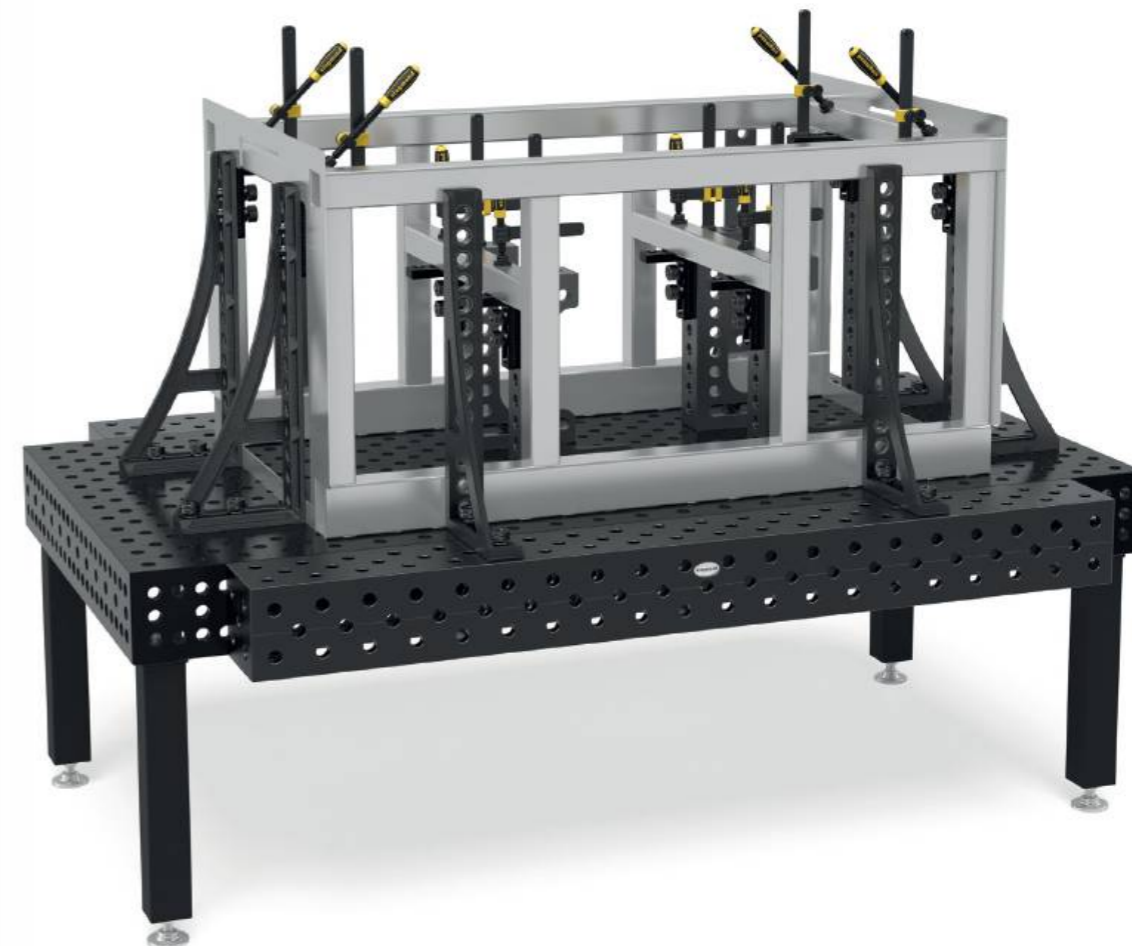

	280110.N	280152.N	280162.N	280164+65.N	280166+67.N	280144+46.N	280910	283999	
	2x	2x						1x	2.026 £ •
	4x	2x	2x					1x	3.575 £ •
	6x	2x	2x		1x			1x	5.159 £ •
	8x	2x	2x	1x	1x		1x	1x	8.115 £ •
	12x	2x	2x	1x	1x	1x	1x	1x	9.898 £ •

Professional Extreme 8.8 PLUS

- Through-hardened tool steel X8.8, plasma nitrided and BAR-coated
- Material thickness approx. 24,5 – 27 mm
- Borehole Ø 28 mm, Boreholes on the surface in diagonal grid
- Height of table side 300 mm, Boreholes on table side 3 rows with 50 mm spacing, 2 rows with 100 mm spacing
- Table side panel made of high quality steel S355J2+N
- incl. leg standard equipment



Table size	Legs	Weight			
1200 x 1200 mm	4	612 kg	4.535 £	4-280015.XD8PL	•
1500 x 1000 mm	4	655 kg	4.892 £	4-280035.XD8PL	•
1500 x 1500 mm	4	901 kg	6.389 £	4-280050.XD8PL	•
2000 x 1000 mm	4	826 kg	5.769 £	4-280020.XD8PL	•
2400 x 1200 mm	4	1102 kg	7.335 £	4-280030.XD8PL	•
3000 x 1500 mm	6	1656 kg	10.488 £	4-280040.XD8PL	•
4000 x 2000 mm	8	2746 kg	16.182 £	4-280055.XD8PL	•

Weight = Table Top + Pallet + Leg standard equipment
 Maximum recommended static total load with 4 legs 6000 kg based on even load distribution. (Data only for leg standard equipment)
 All tables are available on order without plasma nitriding: www.siegmund.com/F-tableX828plus



www.siegmund.com/
F-tableX828plus

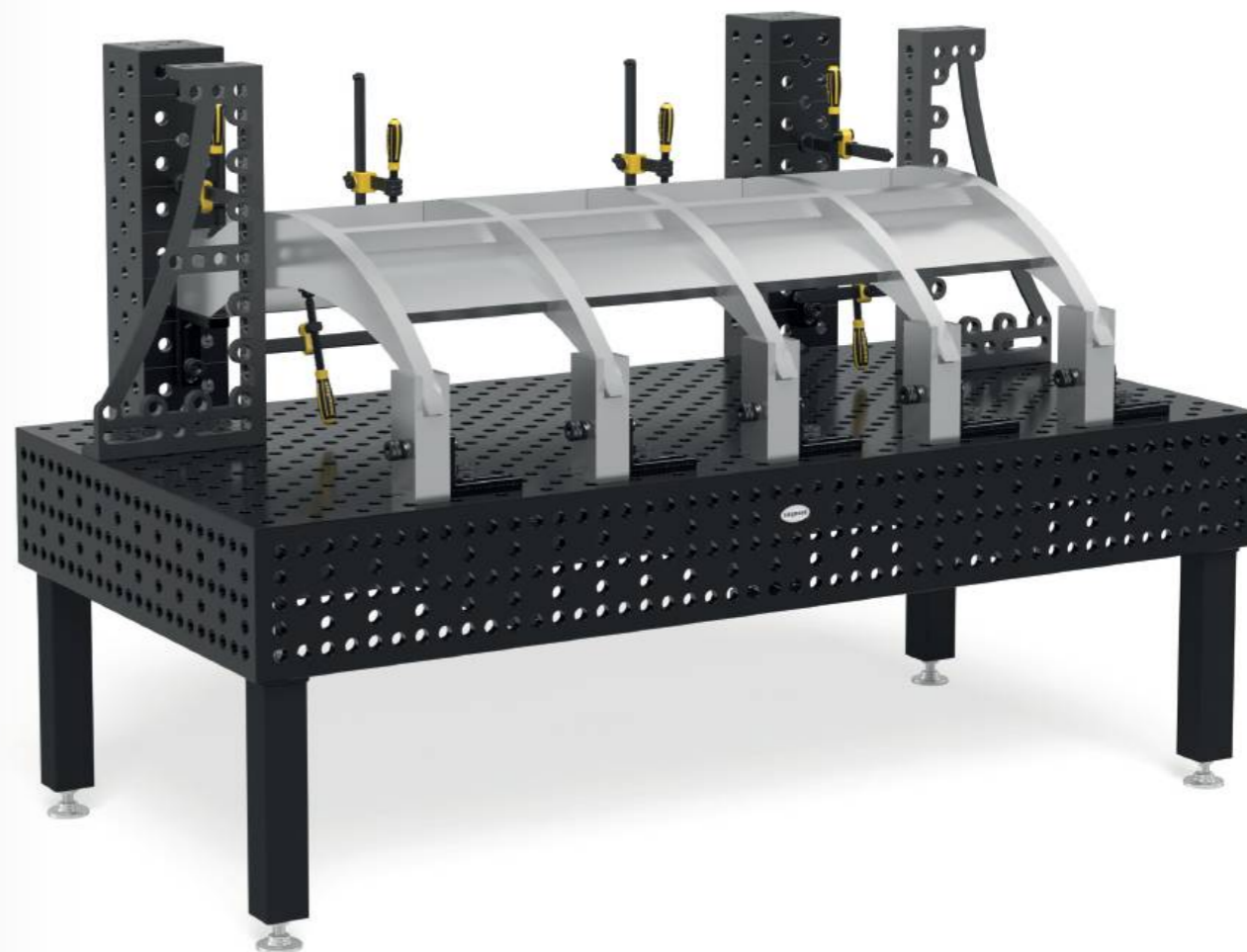

Table Legs



	Standard equipment	Standard equipment	Height adjustable	Height adjustable	Caster, locking brake	Height adjustable, caster, locking brake	Floor anchoring
	280853.X	280857.X	4-280878.1.XX	4-280877.1.XX	4-280860.XX	4-280879.XX	4-280872.XX
Capacity per table leg	3000 kg	2000 kg	2000 kg	2000 kg	1500 kg	1500 kg	3000 kg
Leg height	550 mm	750 mm	450 – 700 mm	550 – 900 mm	550 mm	550 – 750 mm	550 mm
Fine adjustment	50 mm	50 mm	50 mm	50 mm	20 mm	20 mm	50 mm
Surcharge per leg	included	Alternatively	86 £	88 £	109 £	144 £	58 £

Working height = height of table leg + height of side panel of table
 The specified load capacities refer to static load. Note castor: Not recommended for welding tables with 6 or 8 table legs.

Sets



	280610.N	280630.N	280648.1.N	280511	280740	280410.N	280420.N	280430.N
1	4-283100	4x	2x	2x	12x	4x	4x	
2	4-283200	6x	4x	4x	18x	4x	6x	
3	4-283300	10x	6x	4x	24x	4x	8x	
4	4-283400	14x	10x	6x	30x	8x	10x	4x
5	4-283500	14x	10x	8x	36x	8x	12x	4x



	280110.N	280152.N	280162.N	280164+65.N	280166+67.N	280144+46.N	280910	283999	
	2x	2x						1x	2.026 £ •
	4x	2x	2x					1x	3.575 £ •
	6x	2x	2x		1x			1x	5.159 £ •
	8x	2x	2x	1x	1x		1x	1x	8.115 £ •
	12x	2x	2x	1x	1x	1x	1x	1x	9.898 £ •

Hexagon Slot Table

- Through-hardened tool steel X8.7, plasma nitrided and BAR-coated
- Material thickness approx. 24,5 – 27 mm
- Hexagonal Slot distance 100 mm
- Borehole Ø 28 mm, Boreholes on the surface 100x100 mm grid
- Height of table side 200 mm, Boreholes on table sides in diagonal grid
- Table side panel made of high quality steel S355J2+N
- incl. leg standard equipment



Table size	Legs	Weight			
1200 x 1200 mm	4	500 kg	4.436 £	4-280015.HNK	•
1500 x 1000 mm	4	531 kg	4.738 £	4-280035.HNK	•
1500 x 1500 mm	4	734 kg	6.120 £	4-280050.HNK	•
2000 x 1000 mm	4	668 kg	5.690 £	4-280020.HNK	•
2400 x 1200 mm	6	920 kg	7.025 £	4-280030.HNK	•
3000 x 1500 mm	6	1356 kg	10.382 £	4-280040.HNK	•
4000 x 2000 mm	8	2262 kg	16.196 £	4-280055.HNK	•

Weight = Table Top + Pallet + Leg standard equipment
 Maximum recommended static total load with 4 legs 4000 kg based on even load distribution. (Data only for leg standard equipment)



www.siegmund.com/
F-hexagotable

Free with every Hexagon Slot Table

- HN283999:
 4x HN280547 Sliding Block 25 mm
 4x 280546.4 Clamp Bushing



Table Legs



	Standard equipment	Standard equipment	Height adjustable	Height adjustable	Caster, locking brake	Height adjustable, caster, locking brake	Floor anchoring	Floor anchoring
	280858.X	280857.X	4-280878.1.XX	4-280877.1.XX	4-280876.XX	4-280879.XX	4-280874.XX	4-280875.XX
Capacity per table leg	2000 kg	2000 kg	2000 kg	2000 kg	1500 kg	1500 kg	2000 kg	2000 kg
Leg height	650 mm	750 mm	450 – 700 mm	550 – 900 mm	650 mm	550 – 750 mm	650 mm	750 mm
Fine adjustment	50 mm	50 mm	50 mm	50 mm	20 mm	20 mm	50 mm	50 mm
Surcharge per leg	included	Alternatively	86 £	88 £	111 £	144 £	58 £	58 £

Working height = height of table leg + height of side panel of table
 The specified load capacities refer to static load. Note castor: Not recommended for welding tables with 6 or 8 table legs.

Sets



		280610.N	280630.N	280648.1.N	280511	280740	280410.N	280420.N	280430.N
1	4-283100	4x	2x	2x	12x		4x	4x	
2	4-283200	6x	4x	4x	18x	4x	6x	6x	
3	4-283300	10x	6x	4x	24x	4x	8x	8x	
4	4-283400	14x	10x	6x	30x	8x	10x	10x	4x
5	4-283500	14x	10x	8x	36x	8x	12x	12x	4x



	280110.N	280152.N	280162.N	280164+65.N	280166+67.N	280144+46.N	280910	283999	
	2x	2x						1x	2.026 £ •
	4x	2x	2x					1x	3.575 £ •
	6x	2x	2x		1x			1x	5.159 £ •
	8x	2x	2x	1x	1x		1x	1x	8.115 £ •
	12x	2x	2x	1x	1x	1x	1x	1x	9.898 £ •

Siegmund lifting platform

- with two lifting cylinders
- high resilience
- easy handling
- massive scissors and steel rollers
- Contact strip protects against crushing
- Above-floor and underfloor installation possible



Lifting platform 2010

for 2000x1000 mm table, Overall height when retracted: 330 mm, Lifting range: 1100 mm, Lifting time loaded: 45~55 seconds, Force 2,2 kW, Operating voltage 400 V 50 Hz, Maximum load capacity: Basic frame (without a table) 4000 kg, incl. insulation plates

16 22 28

	L (a)	B (b)	G	
4-HB4020.1	1990 mm	990 mm	470 kg	7.197 £ •



Lifting platform 2012

for 2000x1200 mm table, Overall height when retracted: 330 mm, Lifting range: 1100 mm, Lifting time loaded: 45~55 seconds, Force 2,2 kW, Operating voltage 400 V 50 Hz, Maximum load capacity: Basic frame (without a table) 4000 kg, incl. insulation plates

16 22 28

	L (a)	B (b)	G	
4-HB4060.1	1990 mm	1190 mm	490 kg	7.461 £ •



Lifting platform 2412

for 2400x1200 mm table, Overall height when retracted: 330 mm, Lifting range: 1100 mm, Lifting time loaded: 45~55 seconds, Force 2,2 kW, Operating voltage 400 V 50 Hz, Maximum load capacity: Basic frame (without a table) 4000 kg, incl. insulation plates

16 22 28

	L (a)	B (b)	G	
4-HB4030.1	2390 mm	1190 mm	530 kg	7.974 £ •



Lifting platform 3015

for 3000x1500 mm table, Overall height when retracted: 430 mm, Lifting range: 650 mm, Lifting time loaded: 35~45 seconds, Force 2,2 kW, Operating voltage 400 V 50 Hz, Maximum load capacity: Basic frame (without a table) 6000 kg, incl. insulation plates

16 22 28

	L (a)	B (b)	G	
4-HB4040.1	2990 mm	1490 mm	865 kg	12.330 £ •

Lifting platform 2010 with welding table

- incl. welding table 2000x1000 mm and insulation plates
- Material thickness Table Top approx. 24,5 – 27 mm
- Dimensions (L x W): approx. 1990x990 mm
- Weight (without a table) approx. 470 kg
- Overall height when retracted: 330 mm, Lifting range: 1100 mm
- Working height is overall height plus table side panel
- Maximum load capacity: Basic frame (without a table) 4000 kg
- Lifting time loaded: 45~55 seconds
- Force 2,2 kW, Operating voltage 400 V 50 Hz



Size Working surface	Specifications Working surface	G	
2000 x 1000 mm	28 750 N BAR	1166 kg	11.125 £ 4-HB280020.P •
2000 x 1000 mm	28 XB.7 N BAR	1135 kg	12.117 £ 4-HB280020.XD7D •
2000 x 1000 mm	28 XB.8 N BAR	1266 kg	12.691 £ 4-HB280020.XD8PL •
2000 x 1000 mm	28 XB.7 N BAR	1104 kg	12.612 £ 4-HB280020.HNK •

Lifting platform 2012 with welding table

- incl. welding table 2000x1200 mm and insulation plates
- Material thickness Table Top approx. 24,5 – 27 mm
- Dimensions (L x W): approx. 1990x1190 mm
- Weight (without a table) approx. 490 kg
- Overall height when retracted: 330 mm, Lifting range: 1100 mm
- Working height is overall height plus table side panel
- Maximum load capacity: Basic frame (without a table) 4000 kg
- Lifting time loaded: 45~55 seconds
- Force 2,2 kW, Operating voltage 400 V 50 Hz



Size Working surface	Specifications Working surface	G	
2000 x 1200 mm	28 750 N BAR	1299 kg	11.998 £ 4-HB280060.P •
2000 x 1200 mm	28 XB.7 N BAR	1262 kg	13.048 £ 4-HB280060.XD7D •

Lifting platform 2412 with welding table

- incl. welding table 2400x1200 mm and insulation plates
- Material thickness Table Top approx. 24,5 – 27 mm
- Dimensions (L x W): approx. 2390x1190 mm
- Weight (without a table) approx. 530 kg
- Overall height when retracted: 330 mm, Lifting range: 1100 mm
- Working height is overall height plus table side panel
- Maximum load capacity: Basic frame (without a table) 4000 kg
- Lifting time loaded: 45~55 seconds
- Force 2,2 kW, Operating voltage 400 V 50 Hz



Size Working surface	Specifications Working surface	G	
2400 x 1200 mm	28 750 N BAR	1482 kg	13.114 £ 4-HB280030.P •
2400 x 1200 mm	28 XB.7 N BAR	1443 kg	14.340 £ 4-HB280030.XD7D •
2400 x 1200 mm	28 XB.8 N BAR	1602 kg	15.033 £ 4-HB280030.XD8PL •
2400 x 1200 mm	28 XB.7 N BAR	1399 kg	14.585 £ 4-HB280030.HNK •

Lifting platform 3015 with welding table

- incl. welding table 3000x1500 mm and insulation plates
- Material thickness Table Top approx. 24,5 – 27 mm
- Dimensions (L x W): approx. 2990x1490 mm
- Weight (without a table) approx. 865 kg
- Overall height when retracted: 430 mm, Lifting range: 650 mm
- Working height is overall height plus table side panel
- Maximum load capacity: Basic frame (without a table) 6000 kg
- Lifting time loaded: 34~45 seconds
- Force 2,2 kW, Operating voltage 400 V 50 Hz



Size Working surface	Specifications Working surface	G	
3000 x 1500 mm	28 750 N BAR	2331 kg	19.859 £ 4-HB280040.P •
3000 x 1500 mm	28 XB.7 N BAR	2239 kg	21.447 £ 4-HB280040.XD7D •
3000 x 1500 mm	28 XB.8 N BAR	2476 kg	22.404 £ 4-HB280040.XD8PL •
3000 x 1500 mm	28 XB.7 N BAR	2170 kg	22.298 £ 4-HB280040.HNK •



You can find more information and accessories for these products online.



www.siegmund.com/
F-h-lift

Rotating table height adjustable static

- Dimensions (L x W): approx. 785x785 mm
- Weight (without plate): approx. 70 kg
- Working height between 780 mm and 1100 mm
- Due to the danger of tipping, we exclusively recommend the sizes shown
- Only compatible with specified worktops (special attachment points in the worktop)
- Maximum load capacity: Basic frame (without plate) 1000 kg



Size Working surface	Specifications Working surface	MS (d)	G			
1000 x 1000 mm	28 X.B.7 N BAR	25 mm	245 kg	2.372 £	2-DS281010.XD7	•
1200 x 800 mm	28 X.B.7 N BAR	25 mm	238 kg	2.365 £	2-DS281025.XD7	•
1200 x 1200 mm	28 X.B.7 N BAR	25 mm	321 kg	2.690 £	2-DS281015.XD7	•
1000 x 1000 mm	28 X.B.7 N BAR	15 mm	179 kg	2.043 £	2-DS804024.XD7	•
1200 x 1200 mm	28 X.B.7 N BAR	15 mm	226 kg	2.554 £	2-DS804034.XD7	•
1200 x 800 mm	28 X.B.7 N BAR	15 mm	182 kg	2.041 £	2-DS804004.X7	•
Ø 1100 mm	28 X.B.7 N BAR	15 mm	173 kg	2.320 £	2-DS804211.XD7	•

Material thickness 15 mm: For clamping with 280511 bolts a Spacer Ring 800653.1.N is required.

Rotating table height adjustable portable

- Dimensions (L x W): approx. 795x795 mm
- Weight (without plate): approx. 70 kg
- Working height between 780 mm and 1100 mm
- Due to the danger of tipping, we exclusively recommend the sizes shown
- Only compatible with specified worktops (special attachment points in the worktop)
- Maximum load capacity: Basic frame (without plate) 1000 kg



Size Working surface	Specifications Working surface	MS (d)	G			
1000 x 1000 mm	28 X.B.7 N BAR	25 mm	245 kg	2.514 £	2-DM281010.XD7	•
1200 x 800 mm	28 X.B.7 N BAR	25 mm	238 kg	2.507 £	2-DM281025.XD7	•
1200 x 1200 mm	28 X.B.7 N BAR	25 mm	321 kg	2.831 £	2-DM281015.XD7	•
1000 x 1000 mm	28 X.B.7 N BAR	15 mm	179 kg	2.185 £	2-DM804024.XD7	•
1200 x 1200 mm	28 X.B.7 N BAR	15 mm	226 kg	2.696 £	2-DM804034.XD7	•
1200 x 800 mm	28 X.B.7 N BAR	15 mm	182 kg	2.182 £	2-DM804004.X7	•
Ø 1100 mm	28 X.B.7 N BAR	15 mm	173 kg	2.462 £	2-DM804211.XD7	•

Material thickness 15 mm: For clamping with 280511 bolts a Spacer Ring 800653.1.N is required.

Magnetic ground connection

Magnetic ground connection with rotary joint for a high holding force on clean and smooth surfaces. No more twisting cables thanks to the quick and easy grounding. Connection can be clamped or hard-wired. In combination with an adapter plate and countersunk-head screw, it is perfectly suited as a retrofit set for the rotating table.



Magnetic ground connection for rotating table

quick and easy grounding, no cable twisting, high holding force on clean and smooth surfaces, Delivery contents: Adapter plate and countersunk-head screw

16 22 28

	G	
2-00003399	0,92 kg	40 £ •

You can find more information and accessories for these products online.
www.siegmond.com/F-rotating

Mobile lifting table 500 kg

- Dimensions (L x W): approx. 1115x630 mm
- Weight (without plate): approx. 65 kg
- Working height from approx. 700 to 1000 mm
- Only compatible with specified worktops (special attachment points in the worktop)
- Maximum load capacity: Basic frame (without plate) 500 kg



Size Working surface	Specifications Working surface	MS (d)	G			
1200 x 800 mm	28 X.B.7 N BAR	15 mm	177 kg	2.479 £	2-HT804004.X7	•
1500 x 1000 mm	28 X.B.7 N BAR	15 mm	227 kg	2.874 £	2-HT804014.XD7	•

Material thickness 15 mm: For clamping with 280511 bolts a Spacer Ring 800653.1.N is required.

Mobile lifting table 1000 kg

- Dimensions (L x W): approx. 1490x990 mm
- Weight (without plate): approx. 200 kg
- Working height from approx. 700 to 1000 mm
- Fastening via the boreholes
- Maximum load capacity: Basic frame (without plate) 1000 kg



Size Working surface	Specifications Working surface	MS (d)	G			
1500 x 1000 mm	28 X.B.7 N BAR	15 mm	362 kg	3.334 £	2-HS804014.XD7	•
2000 x 1000 mm	28 X.B.7 N BAR	15 mm	417 kg	3.772 £	2-HS804044.XD7	•

Material thickness 15 mm: For clamping with 280511 bolts a Spacer Ring 800653.1.N is required.

Mobile lifting table 1200 kg

- Dimensions (L x W): approx. 1490x990 mm
- Weight (without plate): approx. 210 kg
- Working height from approx. 800 to 1100 mm
- Maximum load capacity: Basic frame (without plate) 1200 kg



Size Working surface	Specifications Working surface	MS (d)	G			
1500 x 1000 mm	28 X.B.7 N BAR	25 mm	678 kg	6.973 £	2-HS280035.XD7D	•

Product recommendation



Supplementary set, load-bearing capacity 1700 kg

Second lifting cylinder for 1700 kg load-bearing capacity (minus plate), Only compatible with mobile lifting table 1200 kg, Scope of delivery: 1x lifting cylinder, 1x foot pedal, fastening material

16 22 28

	G	
2-HS009921	4 kg	474 £ •



Spacer Ring for Premium Light pack of 4 nitrided

distance between two clamping elements, is required for clamping to material thickness 15 mm with bolt 280511, Scope of delivery: 4 pieces

16 22 28

	MS (d)	G	
2-800653.1.N	10 mm	0,04 kg	10 £ •

You can find more information and accessories for these products online.
www.siegmond.com/F-lifting

MS: Material thickness, G: Weight, Ø: Diameter

Siegmund Workstation 1208

- left and right 600 mm space for drawers
- incl. Perforated plate 1200x800 mm Premium Light
- Through-hardened tool steel X8.7, plasma nitrided and BAR-coated
- Borehole Ø 28 mm
- Boreholes on the surface 100x100 mm grid
- Maximum load capacity: base plate 1000 kg (without plate) / Castor 400 kg (without plate)



Siegmund Workstation 1208		Delivery contents: 1x 004002.1 Siegmund Workstation 1208 Basic frame, 1x 804004.X7 Perforated plate						
	L (a)	B (b)	H (c)	G	Special offer price			
2-284400	1200 mm	800 mm	850 mm	144 kg	1.494 £	• instead of 1.517 £		
Siegmund Workstation 1208 incl. Shelves		Delivery contents: 1x 004002.1 Siegmund Workstation 1208 Basic frame, 1x 804004.X7 Perforated plate, 1x 284030 Clamp holder, 1x 004620 Shelf, 1x 284635 Bolt and prism holder, 1x 004025.1 Toolwall incl. Shelf						
2-284401	1200 mm	800 mm	850 mm	153,79 kg	1.629 £	• instead of 1.661 £		
Siegmund Workstation 1208 half closed incl. 3 drawers		Delivery contents: 1x 004002.1 Siegmund Workstation 1208 Basic frame, 1x 804004.X7 Perforated plate, 2x 004230 Drawer 180 mm, 1x 004235 Drawer 240 mm, 1x 004120 Set side walls						
2-284407	1200 mm	800 mm	850 mm	176,50 kg	1.924 £	• instead of 1.953 £		
Siegmund Workstation 1208 closed incl. 6 drawers		Delivery contents: 1x 004002.1 Siegmund Workstation 1208 Basic frame, 1x 804004.X7 Perforated plate, 4x 004230 Drawer 180 mm, 2x 004235 Drawer 240 mm, 2x 004120 Set side walls						
2-284409	1200 mm	800 mm	850 mm	209 kg	2.354 £	• instead of 2.388 £		

Material thickness 15 mm. For clamping with 280511 bolts a Spacer Ring 800653.1.N is required. plus packaging / Shipping

Siegmund Workstation 1208 – Configuration

Equipment with 4 castors for Workstation 1208		switch between feet and castors possible						
	TF	G				Special offer price		
2-004100.1	400 kg	5,30 kg				78 £	•	
Drawer with clip rail and mounting for Workstation 0806 / 1208		powder coated finish, upgrading possible at any time, for Workstation 0806 / 1208 without side walls, mounting is required if there are no side walls in the Workstation						
	L (a)	B (b)	H (c)	TF	G	Special offer price		
2-004220.WS	590 mm	400 mm	60 mm	50 kg	7,50 kg	87 £	•	
2-004225.WS	590 mm	400 mm	120 mm	50 kg	9 kg	98 £	•	
2-004230.WS	590 mm	400 mm	180 mm	50 kg	9,50 kg	109 £	•	
2-004235.WS	590 mm	400 mm	240 mm	50 kg	10 kg	120 £	•	



Product recommendation

Set Extension Premium Light for perforated plates Premium Light 1 row of holes		Consisting of: 1x 804050 Extension Premium Light for perforated plates Premium Light 1 row of holes incl. 4 set screws, 1x 800528 Flush Mount Bolt Premium Light <-> Premium Light						
	L (a)	L (a1)	B (b)	H (c)	G	Special offer price		
2-804050.Set	381 mm	300 mm	99 mm	40 mm	4,90 kg	120 £	• instead of 138 £	
Set External stop bracket Premium Light for perforated plates Premium Light		Consisting of: 1x 804051 External stop bracket Premium Light for perforated plates Premium Light incl. 4 set screws, 1x 800528 Flush Mount Bolt Premium Light <-> Premium Light						
2-804051.Set	340 mm	300 mm	99 mm	114 mm	5,10 kg	120 £	• instead of 138 £	
Spacer Ring for Premium Light pack of 4 nitrided		distance between two clamping elements, is required for clamping to material thickness 15 mm with bolt 280511, Scope of delivery: 4 pieces						
2-800653.1.N	MS (d)		G					
		10 mm		0,04 kg		10 £	•	

Siegmund Workstation 1212

- left and right 600 mm space for drawers
- incl. Perforated plate 1200x1200 mm Premium Light
- Through-hardened tool steel X8.7, plasma nitrided and BAR-coated
- Borehole Ø 28 mm
- Boreholes on the surface 100x100 mm grid
- Maximum load capacity: base plate 1000 kg (without plate) / Castor 400 kg (without plate)



Siegmund Workstation 1212

Delivery contents: 1x 004602 Siegmund Workstation 1212 Basic frame, 1x 804034.X7 Perforated plate



	L (a)	B (b)	H (c)	G	Special offer price
2-284600	1200 mm	1200 mm	850 mm	208,80 kg	1.862 £ • instead of 1.883 £

Siegmund Workstation 1212 incl. Shelves

Delivery contents: 1x 004602 Siegmund Workstation 1212 Basic frame, 1x 804034.X7 Perforated plate, 1x 284630 Clamp holder, 1x 004620 Shelf, 1x 284635 Bolt and prism holder, 1x 004625 Toolwall incl. Shelf



	L (a)	B (b)	H (c)	G	Special offer price
2-284601	1200 mm	1200 mm	850 mm	221,55 kg	2.006 £ • instead of 2.037 £

Siegmund Workstation 1212 half closed incl. 3 drawers

Delivery contents: 1x 004602 Siegmund Workstation 1212 Basic frame, 1x 804034.X7 Perforated plate, 2x 004230 Drawer 180 mm, 1x 004235 Drawer 240 mm, 1x 004720 Set side walls



	L (a)	B (b)	H (c)	G	Special offer price
2-284607	1200 mm	1200 mm	850 mm	242,80 kg	2.300 £ • instead of 2.327 £

Siegmund Workstation 1212 closed incl. 6 drawers

Delivery contents: 1x 004602 Siegmund Workstation 1212 Basic frame, 1x 804034.X7 Perforated plate, 4x 004230 Drawer 180 mm, 2x 004235 Drawer 240 mm, 2x 004720 Set side walls



	L (a)	B (b)	H (c)	G	Special offer price
2-284609	1200 mm	1200 mm	850 mm	276,80 kg	2.738 £ • instead of 2.770 £

Material thickness 15 mm. For clamping with 280511 bolts a Spacer Ring 800653.1.N is required. plus packaging / Shipping

Siegmund Workstation 1212 – Configuration

Equipment with 4 castors for Workstation 1212

switch between feet and castors possible



	TF	G	Special offer price
2-004700	400 kg	4,30 kg	86 £ •

Drawer with clip rail and mounting for Workstation 1212

powder coated finish, upgrading possible at any time, for Workstation 1212 without side walls, mounting is required if there are no side walls in the Workstation

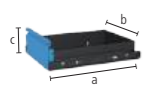

	L (a)	B (b)	H (c)	TF	G	Special offer price
2-004820.WS	590 mm	400 mm	60 mm	50 kg	8 kg	92 £ •
2-004825.WS	590 mm	400 mm	120 mm	50 kg	9,50 kg	103 £ •
2-004830.WS	590 mm	400 mm	180 mm	50 kg	10 kg	114 £ •
2-004835.WS	590 mm	400 mm	240 mm	50 kg	10,50 kg	125 £ •



Product recommendation

Tool-Set A

2x 280610.N Clamp, 6x 280511 Bolt, 2x 800653.1.N Spacer Ring, 6x 280412 Stop, 1x 280852.1 Hex wrench



	G	Special offer price
2-287320	9,79 kg	482 £ • instead of 685 £

Tool-Set B

4x 280610.N Clamp, 8x 280511 Bolt, 3x 800653.1.N Spacer Ring, 6x 280412 Stop, 2x 280420.N Stop, 1x 280852.1 Hex wrench, 1x 284320 Bench vice incl. Set of vice jaw covers



	G	Special offer price
2-287340.1	37,72 kg	983 £ • instead of 1.505 £

Tool-Set C

6x 280610.N Clamp, 12x 280511 Bolt, 4x 800653.1.N Spacer Ring, 4x 280412 Stop, 2x 280420.N Stop, 2x 280152.N Square, 2x 804050 Extension for perforated plates, 2x 800528 Flush Mount Bolt, 1x 280852.1 Hex wrench, 1x 284320 Set Siegmund bench vice 125



	G	Special offer price
2-287360	66,74 kg	1.727 £ • instead of 2.467 £



Configure your workstation



www.siegmund.com/
F-workstation

Octagonal Table 200

fixation via adapter plate (not included in the scope of delivery), Adapter plate available on request at an additional cost, Discount: starting at 2 pieces: 5%, starting at 5 pieces: 10%



	L (a)	B (b)	H (c)	MS (d)	Ø	G	
2-920800.P	331 mm	800 mm	200 mm	25 mm	866 mm	261 kg	5.750 £ ◦
2-921000.P	414 mm	1000 mm	200 mm	25 mm	1082 mm	386 kg	6.595 £ ◦
2-921200.P	497 mm	1200 mm	200 mm	25 mm	1299 mm	514 kg	9.808 £ ◦
2-921400.P	580 mm	1400 mm	200 mm	25 mm	1515 mm	660 kg	10.654 £ ◦
2-921500.P	621 mm	1500 mm	200 mm	25 mm	1624 mm	726 kg	11.499 £ ◦
2-921600.P	663 mm	1600 mm	200 mm	25 mm	1732 mm	825 kg	12.344 £ ◦
2-921700.P	704 mm	1700 mm	200 mm	25 mm	1840 mm	896 kg	13.395 £ ◦
2-921800.P	746 mm	1800 mm	200 mm	25 mm	1948 mm	974 kg	13.190 £ ◦

Octagonal Table 100

fixation via adapter plate (not included in the scope of delivery), Adapter plate available on request at an additional cost, Discount: starting at 2 pieces: 5%, starting at 5 pieces: 10%



	L (a)	B (b)	H (c)	MS (d)	Ø	G	
2-920800.1.P	331 mm	800 mm	100 mm	25 mm	866 mm	203 kg	5.071 £ ◦
2-921000.1.P	414 mm	1000 mm	100 mm	25 mm	1082 mm	279 kg	5.750 £ ◦
2-921200.1.P	497 mm	1200 mm	100 mm	25 mm	1299 mm	380 kg	7.439 £ ◦
2-921400.1.P	580 mm	1400 mm	100 mm	25 mm	1515 mm	501 kg	9.132 £ ◦
2-921500.1.P	621 mm	1500 mm	100 mm	25 mm	1624 mm	557 kg	9.808 £ ◦
2-921600.1.P	663 mm	1600 mm	100 mm	25 mm	1732 mm	649 kg	10.146 £ ◦
2-921700.1.P	704 mm	1700 mm	100 mm	25 mm	1840 mm	705 kg	11.386 £ ◦
2-921800.1.P	746 mm	1800 mm	100 mm	25 mm	1948 mm	780 kg	12.344 £ ◦

Octagonal Plate

fixation through bore holes using support sleeves (280500), M8 thread on the side, Discount: starting at 2 pieces: 5%, starting at 5 pieces: 10%

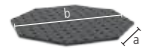

	L (a)	B (b)	H (c)	MS (d)	Ø	G	
2-940600.P	249 mm	600 mm	25 mm	25 mm	650 mm	94 kg	2.705 £ ◦
2-940800.P	331 mm	800 mm	25 mm	25 mm	866 mm	139 kg	3.381 £ ◦
2-941000.P	414 mm	1000 mm	25 mm	25 mm	1083 mm	198 kg	4.057 £ ◦
2-941200.P	497 mm	1200 mm	25 mm	25 mm	1299 mm	280 kg	5.113 £ ◦
2-941400.P	580 mm	1400 mm	25 mm	25 mm	1516 mm	388 kg	6.434 £ ◦
2-941500.P	621 mm	1500 mm	25 mm	25 mm	1636 mm	435 kg	6.820 £ ◦

Weight = Octagonal Plate + Pallet
Due to customer specific adaptation the weight can vary.
Further table sizes are available on request.
Foot plates or adapter plates are not included as standard in the octagonal tables.

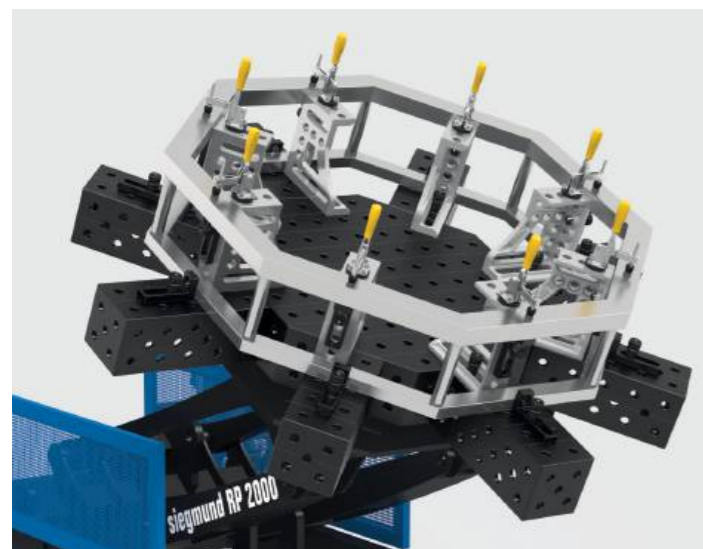

Octagonal Table Premium Light 200

Up to 40% weight reduction compared to conventionally used material, fixation via adapter plate (not included in the scope of delivery), Discount: starting at 2 pieces: 5%, starting at 5 pieces: 10%



	L (a)	B (b)	H (c)	MS (d)	Ø	G	
2-820800.X7	331 mm	800 mm	200 mm	15 mm	866 mm	221 kg	5.750 £ ◦
2-821000.X7	414 mm	1000 mm	200 mm	15 mm	1082 mm	285 kg	6.595 £ ◦
2-821200.X7	497 mm	1200 mm	200 mm	15 mm	1299 mm	373 kg	9.808 £ ◦
2-821400.X7	580 mm	1400 mm	200 mm	15 mm	1515 mm	467 kg	10.654 £ ◦
2-821500.X7	621 mm	1500 mm	200 mm	15 mm	1624 mm	511 kg	11.499 £ ◦
2-821600.X7	663 mm	1600 mm	200 mm	15 mm	1732 mm	585 kg	12.344 £ ◦
2-821700.X7	704 mm	1700 mm	200 mm	15 mm	1840 mm	640 kg	13.395 £ ◦
2-821800.X7	746 mm	1800 mm	200 mm	15 mm	1948 mm	679 kg	13.190 £ ◦

Octagonal Table Premium Light 100

Up to 40% weight reduction compared to conventionally used material, fixation via adapter plate (not included in the scope of delivery), Discount: starting at 2 pieces: 5%, starting at 5 pieces: 10%



	L (a)	B (b)	H (c)	MS (d)	Ø	G	
2-820800.1.X7	331 mm	800 mm	100 mm	15 mm	866 mm	152 kg	5.071 £ ◦
2-821000.1.X7	414 mm	1000 mm	100 mm	15 mm	1082 mm	199 kg	5.750 £ ◦
2-821200.1.X7	497 mm	1200 mm	100 mm	15 mm	1299 mm	269 kg	7.439 £ ◦
2-821400.1.X7	580 mm	1400 mm	100 mm	15 mm	1515 mm	350 kg	9.132 £ ◦
2-821500.1.X7	621 mm	1500 mm	100 mm	15 mm	1624 mm	381 kg	9.808 £ ◦
2-821600.1.X7	663 mm	1600 mm	100 mm	15 mm	1732 mm	450 kg	10.146 £ ◦
2-821700.1.X7	704 mm	1700 mm	100 mm	15 mm	1840 mm	487 kg	11.386 £ ◦
2-821800.1.X7	746 mm	1800 mm	100 mm	15 mm	1948 mm	527 kg	12.344 £ ◦

Octagonal Plate Premium Light

Up to 40% weight reduction compared to conventionally used material, fixation through bore holes using support sleeves (280500), M8 thread on the side, Discount: starting at 2 pieces: 5%, starting at 5 pieces: 10%



	L (a)	B (b)	H (c)	MS (d)	Ø	G	
2-840600.X7	249 mm	600 mm	15 mm	15 mm	650 mm	69 kg	2.705 £ ◦
2-840800.X7	331 mm	800 mm	15 mm	15 mm	866 mm	95 kg	3.381 £ ◦
2-841000.X7	414 mm	1000 mm	15 mm	15 mm	1083 mm	142 kg	4.057 £ ◦
2-841200.X7	497 mm	1200 mm	15 mm	15 mm	1299 mm	205 kg	5.113 £ ◦
2-841400.X7	580 mm	1400 mm	15 mm	15 mm	1516 mm	254 kg	6.434 £ ◦
2-841500.X7	621 mm	1500 mm	15 mm	15 mm	1636 mm	310 kg	6.820 £ ◦

Weight = Octagonal Plate + Pallet
Due to customer specific adaptation the weight can vary.
Further table sizes are available on request.
Foot plates or adapter plates are not included as standard in the octagonal tables.

Adapter plate available on request at an additional cost

Surcharge for customizing Adapter Plate

for octagonal tables with side panels



0-940000

719 £ ◦

Surcharge for customization of the drill circle

for octagonal plates

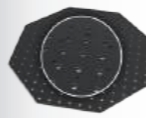

0-940000.1

535 £ ◦

You can find more information and accessories for these products online.
www.siegmund.com/F-octagonal28

Eccentric Stop Ø 60 / Ø 100 nitrided
also serves as a support surface, stepless adjusting



	MS (d)	Ø	G	
2-280401.N	25 mm	60 mm	0,42 kg	23 £ •
2-280403.N	25 mm	100 mm	1,40 kg	28 £ •

Eccentric Stop Ø 60 with M10 thread nitrided
for ground connection, stepless adjusting



	MS (d)	Ø	G	
2-280402.N	25 mm	60 mm	0,41 kg	28 £ •

Flex Stop 25x140 Steel Galvanized
elongated hole, used where space is restricted



	L (a)	B (b)	VB (f)	MS (d)	WS (d1)	G	
2-280416	140 mm	40 mm	100 mm	25 mm	6 mm	0,37 kg	25 £ •

Flex Stop 25x156 Aluminum
elongated hole, used where space is restricted



	L (a)	B (b)	VB (f)	MS (d)	WS (d1)	G	
2-280412	156 mm	52 mm	100 mm	25 mm	12 mm	0,30 kg	24 £ •

Universal Stop 150 L / 200 L / 250 L nitrided
elongated hole



	L (a)	B (b)	VB (f)	MS (d)	G	
2-280410.N	150 mm	50 mm	100 mm	25 mm	0,78 kg	41 £ •
2-280410.1.N	200 mm	50 mm	150 mm	25 mm	1 kg	48 £ •
2-280410.2.N	250 mm	50 mm	200 mm	25 mm	1,20 kg	51 £ •

Universal Stop 150 L / 225 L Aluminum
elongated hole

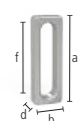

	L (a)	B (b)	VB (f)	MS (d)	G	
2-280410.A	150 mm	50 mm	100 mm	25 mm	0,30 kg	43 £ •
2-280420.A	225 mm	50 mm	100 mm	25 mm	0,55 kg	62 £ •

Universal Stop 225 L nitrided
combination of borehole and elongated hole, for use with both prisms and adapters



	L (a)	B (b)	VB (f)	MS (d)	G	
2-280420.N	225 mm	50 mm	100 mm	25 mm	1,40 kg	62 £ •

Universal Stop 300 / 325 L / 500 / 525 L nitrided
combination of borehole and elongated hole

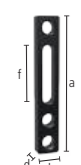

	L (a)	B (b)	VB (f)	MS (d)	G	
2-280426.N	300 mm	50 mm	100 mm	25 mm	1,85 kg	62 £ •
2-280422.N	325 mm	50 mm	100 mm	25 mm	2,10 kg	64 £ •
2-280427.N	500 mm	50 mm	100 mm	25 mm	3,30 kg	83 £ •
2-280424.N	525 mm	50 mm	100 mm	25 mm	3,50 kg	79 £ •



Universal Stop 225 L FDS with spring pressure part burnished
with spring pressure part, combination of borehole and elongated hole



	L (a)	B (b)	VB (f)	MS (d)	G	
2-280421	225 mm	50 mm	100 mm	25 mm	1,40 kg	62 £ •

Universal Stop 100 / 150 / 250 nitrided
with boreholes, no elongated hole, borehole spacing 50 mm



	L (a)	B (b)	MS (d)	G	
2-280407.N	100 mm	50 mm	25 mm	0,75 kg	26 £ •
2-280408.N	150 mm	50 mm	25 mm	1,10 kg	33 £ •
2-280409.N	250 mm	50 mm	25 mm	1,80 kg	48 £ •

Angle Alignment Template nitrided
incl. 2x Spacer Sleeve, infinite adjustment from 0-90°



	L (a)	B (b)	MS (d)	G	
2-280455.N	250 mm	250 mm	5 mm	1,50 kg	57 £ •

Universal Stop 500 S / 750 S / 1000 S nitrided
combination of borehole and elongated hole



	L (a)	B (b)	VB (f)	MS (d)	G	
2-280430.N	500 mm	100 mm	200 mm	25 mm	7,90 kg	86 £ •
2-280432.N	750 mm	100 mm	200 mm	25 mm	12,10 kg	109 £ •
2-280434.N	1000 mm	100 mm	200 mm	25 mm	16,30 kg	123 £ •

Flat Square 175 / 500 burnished
combination of borehole and elongated hole



	L (a)	B (b)	H (c)	MS (d)	G	
2-280445	175 mm	175 mm	50 mm	25 mm	1,85 kg	87 £ •
2-280444	500 mm	375 mm	100 mm	25 mm	12 kg	218 £ •

You can find more information and accessories for these products online.



www.siegmund.com/
F-stop28

Stop and Clamping Square 75 L / 175 VL nitrided
with boreholes, no elongated hole

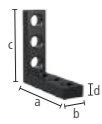

	L (a)	B (b)	H (c)	MS (d)	G	
2-280105.N	75 mm	50 mm	75 mm	25 mm	1 kg	51 £ •
2-280113.N	175 mm	50 mm	175 mm	25 mm	2,40 kg	99 £ •

Stop and Clamping Square 175 SL / 175 ML / 175 L / 275 L nitrided
combination of borehole and elongated hole

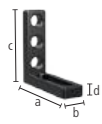

	L (a)	B (b)	H (c)	MS (d)	G	
2-280109.N	175 mm	50 mm	75 mm	25 mm	1,40 kg	84 £ •
2-280109.1.N	175 mm	50 mm	125 mm	25 mm	1,80 kg	90 £ •
2-280110.N	175 mm	50 mm	175 mm	25 mm	1,95 kg	107 £ •
2-280112.N	175 mm	50 mm	275 mm	25 mm	2,80 kg	117 £ •

Stop and Clamping Square 275 WL nitrided
combination of borehole and elongated hole, elongated hole 200 mm

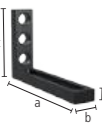

	L (a)	B (b)	H (c)	MS (d)	G	
2-280115.N	275 mm	50 mm	175 mm	25 mm	2,50 kg	117 £ •

Stop and Clamping Square 175 L Aluminum
combination of borehole and elongated hole

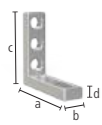

	L (a)	B (b)	H (c)	MS (d)	G	
2-280110.A	175 mm	50 mm	175 mm	25 mm	0,80 kg	119 £ •

Stop and Clamping Square 175 WL nitrided
elongated hole, flexible in any direction



	L (a)	B (b)	H (c)	MS (d)	G	
2-280111.N	175 mm	50 mm	175 mm	25 mm	1,80 kg	107 £ •



Stop and Clamping Square 200 L nitrided
combination of borehole and elongated hole

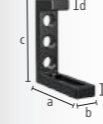

	L (a)	B (b)	H (c)	MS (d)	G	
2-280114.N	175 mm	50 mm	200 mm	25 mm	2,71 kg	129 £ •

Stop and Clamping Square 300 G / 500 G / 750 G nitrided
usable as table extension, material: GGG40, recommended as a pair

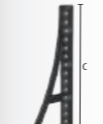

	L (a)	B (b)	H (c)	MS (d)	G		
2-280152.N	left	200 mm	75 mm	300 mm	27 mm	6,52 kg	167 £ •
2-280162.N	left	200 mm	75 mm	500 mm	27 mm	9,40 kg	218 £ •
2-280166.N	left	276 mm	85 mm	750 mm	27 mm	13,60 kg	267 £ •
2-280167.N	right	276 mm	85 mm	750 mm	27 mm	13,60 kg	267 £ •

Stop and Clamping Square 300 GK / 500 GK nitrided
usable as table extension, for heavy components, material: GGG40, recommended as a pair

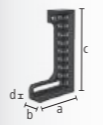

	L (a)	B (b)	H (c)	MS (d)	G		
2-280124.N	left	280 mm	95 mm	300 mm	27 mm	12,90 kg	263 £ •
2-280126.N	right	280 mm	95 mm	300 mm	27 mm	12,90 kg	263 £ •
2-280130.N	left	280 mm	95 mm	500 mm	27 mm	17,50 kg	326 £ •
2-280132.N	right	280 mm	95 mm	500 mm	27 mm	17,50 kg	326 £ •

Stop and Clamping Square 500 G with rotation angle nitrided
usable as table extension, material: GGG40, recommended as a pair

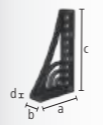

	L (a)	B (b)	H (c)	MS (d)	G		
2-280164.N	left	276 mm	95 mm	500 mm	27 mm	11,50 kg	305 £ •
2-280165.N	right	276 mm	95 mm	500 mm	27 mm	11,50 kg	305 £ •

Stop and Clamping Square 600 GK / 800 GK nitrided
usable as table extension, for heavy components, material: GGG40, recommended as a pair

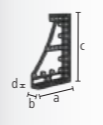

	L (a)	B (b)	H (c)	MS (d)	G		
2-280134.N	left	376 mm	95 mm	600 mm	27 mm	22,50 kg	395 £ •
2-280136.N	right	376 mm	95 mm	600 mm	27 mm	22,50 kg	395 £ •
2-280144.N	left	376 mm	95 mm	800 mm	27 mm	27 kg	483 £ •
2-280146.N	right	376 mm	95 mm	800 mm	27 mm	27 kg	483 £ •

Stop and Clamping Square 300 GK / 600 GK / 800 GK / 1200 GK
usable as table extension, for heavy components, hardness of nitrided cast steel is not achieved, recommended as a pair

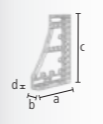

	L (a)	B (b)	H (c)	MS (d)	G		
2-280120	left	280 mm	95 mm	300 mm	27 mm	5 kg	304 £ •
2-280121	right	280 mm	95 mm	300 mm	27 mm	5 kg	304 £ •
2-280138	left	376 mm	95 mm	600 mm	27 mm	8,70 kg	475 £ •
2-280139	right	376 mm	95 mm	600 mm	27 mm	8,70 kg	475 £ •
2-280140	left	376 mm	95 mm	800 mm	27 mm	10,40 kg	584 £ •
2-280141	right	376 mm	95 mm	800 mm	27 mm	10,40 kg	584 £ •
2-280148	left	376 mm	95 mm	1200 mm	27 mm	13,50 kg	923 £ •
2-280149	right	376 mm	95 mm	1200 mm	27 mm	13,50 kg	923 £ •

Corner Connection small / large Cast Iron nitrided
45° diagonal table extension, material: GGG40



	L (a)	B (b)	H (c)	G	
2-280190.N	200 mm	150 mm	120 mm	11,80 kg	235 £ •
2-280191.N	200 mm	200 mm	170 mm	15,70 kg	315 £ •

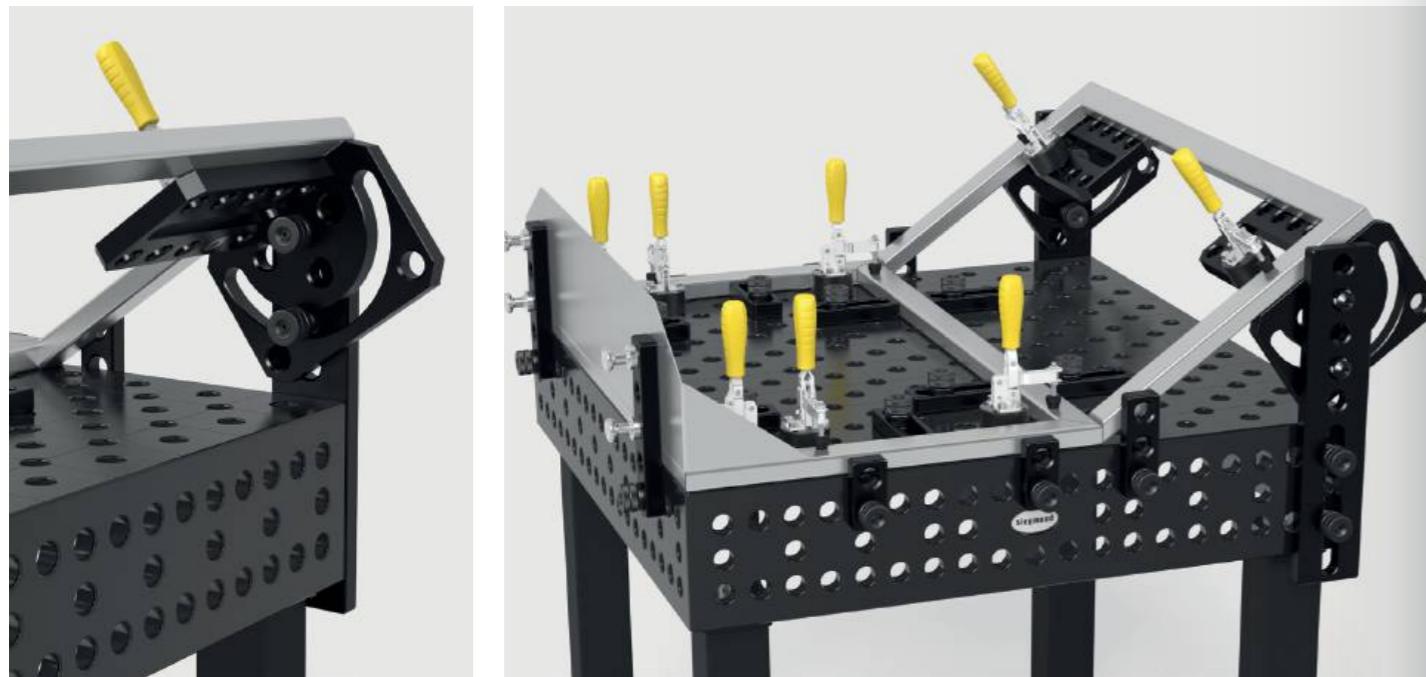

Sliding Base nitrided

Combination of a square with the sliding base enables sliding in two axes, material: GGG40



	L (a)	B (b)	H (c)	G	
2-280195.N	350 mm	300 mm	50 mm	16 kg	339 £ •

Rotation Angle 275 nitrided

180° infinite adjustment

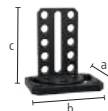

	L (a)	B (b)	H (c)	G	
2-280101.N	180 mm	250 mm	275 mm	10,20 kg	362 £ •

Universal Angle Mechanical Clamping nitrided

includes setting template, 10° to 150° adjustment

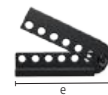

	SL (e)	G	
2-280170.N	350 mm	14,50 kg	395 £ •

Universal Angle Hydromechanical Clamping nitrided

225° infinite adjustment, suitable matching hex wrench 14 (280854) not included



	SL (e)	G	
2-280171.N	475 mm	23 kg	655 £ •

Support and Clamping Frame, Cast Iron 300x200x100 nitrided

borehole spacing 50 mm, material: GGG40



	L (a)	B (b)	H (c)	MS (d)	G	
2-280300.N right	300 mm	200 mm	100 mm	25 mm	19,50 kg	337 £ •
2-280301.N left	300 mm	200 mm	100 mm	25 mm	19,50 kg	337 £ •



You can find more information and accessories for these products online.



www.siegmund.com/
F-square28

Clamping Block 400x350x200 Plasma nitrided

five-sided, borehole spacing 50 mm



	L (a)	B (b)	H (c)	MS (d)	G	
2-280285.P	400 mm	350 mm	200 mm	25 mm	60 kg	759 £ •

Moveable Square nitrided

four-sided table extension, table setup or stop bar, material: GGG40



	L (a)	B (b)	H (c)	G	
2-280302.N	500 mm	100 mm	100 mm	15,80 kg	279 £ •

Clamping Rail nitrided

versatile connecting element

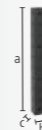

	L (a)	B (b)	H (c)	MS (d)	G	
2-280303.P	1000 mm	100 mm	100 mm	25 mm	48 kg	757 £ •
2-280303.1.P	2000 mm	100 mm	100 mm	25 mm	95 kg	1.230 £ •
2-280303.2.P	3000 mm	100 mm	100 mm	25 mm	141 kg	1.992 £ •

Square U-Shape 200x100 elongated hole Plasma nitrided

with elongated hole, to connect tables (with connecting bolt 280563), as table extension and vertical superstructure, from 500 mm with mounting holes for table legs, from 1000 mm support through table leg required



	L (a)	B (b)	H (c)	MS (d)	G	
2-280311.P	500 mm	200 mm	100 mm	25 mm	40 kg	548 £ •
2-280312.P	500 mm	200 mm	100 mm	25 mm	40 kg	548 £ •
2-280321.P	1000 mm	200 mm	100 mm	25 mm	72 kg	869 £ •
2-280322.P	1000 mm	200 mm	100 mm	25 mm	72 kg	869 £ •



Square U-Shape 200x100 Plasma nitrided

to connect tables (with connecting bolt 280563), as table extension and vertical superstructure, from 1000 mm with mounting holes for table legs, from 1000 mm support through table leg required

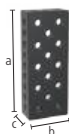

	L (a)	B (b)	H (c)	MS (d)	G	
2-280310.P	500 mm	200 mm	100 mm	25 mm	31 kg	452 £ •
2-280320.P	1000 mm	200 mm	100 mm	25 mm	75 kg	790 £ •
2-280330.P	1500 mm	200 mm	100 mm	25 mm	108 kg	1.195 £ •
2-280340.P	2000 mm	200 mm	100 mm	25 mm	141 kg	1.532 £ •

Square U-Shape 200x200 Plasma nitrided

to connect tables (with connecting bolt 280563), as table extension and vertical superstructure, from 500 mm with mounting holes for table legs, from 1000 mm support through table leg required, can be used on foundation rail with leg 280371



	L (a)	B (b)	H (c)	MS (d)	G	
2-280396.P	100 mm	200 mm	200 mm	25 mm	21 kg	363 £ •
2-280396.1.P	200 mm	200 mm	200 mm	25 mm	31 kg	444 £ •
2-280360.P	500 mm	200 mm	200 mm	25 mm	67 kg	572 £ •
2-280362.P	600 mm	200 mm	200 mm	25 mm	77 kg	726 £ •
2-280366.P	800 mm	200 mm	200 mm	25 mm	99 kg	878 £ •
2-280370.P	1000 mm	200 mm	200 mm	25 mm	120 kg	969 £ •
2-280374.P	1200 mm	200 mm	200 mm	25 mm	140 kg	1.207 £ •
2-280378.P	1400 mm	200 mm	200 mm	25 mm	162 kg	1.334 £ •
2-280380.P	1500 mm	200 mm	200 mm	25 mm	172 kg	1.381 £ •
2-280382.P	1600 mm	200 mm	200 mm	25 mm	182 kg	1.491 £ •
2-280386.P	1800 mm	200 mm	200 mm	25 mm	204 kg	1.620 £ •
2-280390.P	2000 mm	200 mm	200 mm	25 mm	225 kg	1.706 £ •
2-280391.P	2400 mm	200 mm	200 mm	25 mm	266 kg	2.094 £ •
2-280392.P	3000 mm	200 mm	200 mm	25 mm	331 kg	2.625 £ •
2-280394.P	4000 mm	200 mm	200 mm	25 mm	439 kg	3.252 £ •

Square U-Shape 200x200 Premium Light Plasma nitrided

to connect tables (with connecting bolt 800564), for clamping with 280511 bolts Spacer Ring 800653.1.N is required, from 500 mm with mounting holes for table legs, from 1000 mm support through table leg required, can be used on foundation rail with leg 280371



	L (a)	B (b)	H (c)	MS (d)	G	
2-800360.X7	500 mm	200 mm	200 mm	15 mm	42 kg	551 £ •
2-800370.X7	1000 mm	200 mm	200 mm	15 mm	76 kg	933 £ •
2-800380.X7	1500 mm	200 mm	200 mm	15 mm	110 kg	1.330 £ •
2-800390.X7	2000 mm	200 mm	200 mm	15 mm	143 kg	1.639 £ •

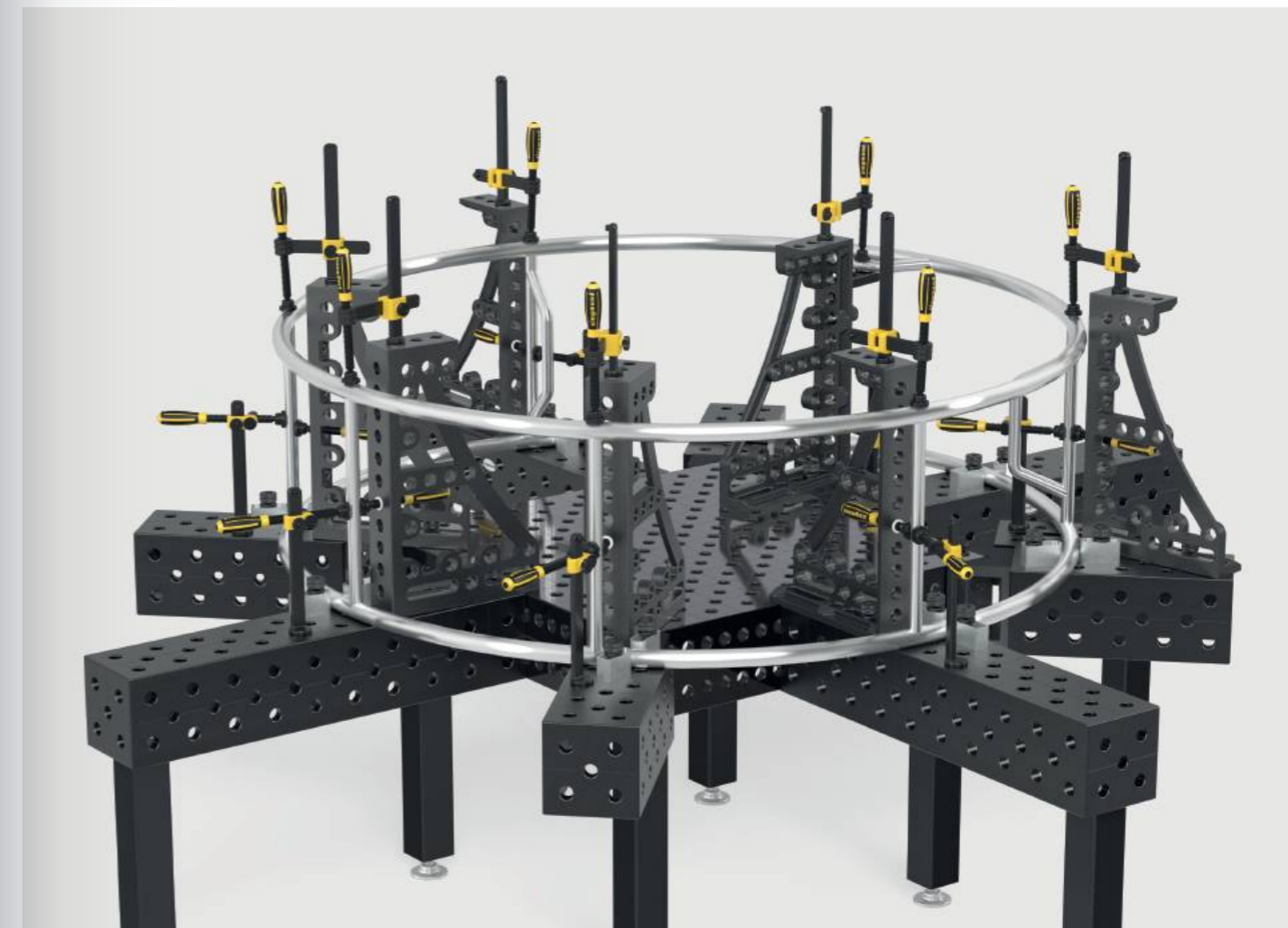

Square U-Shape 400x200 Plasma nitrided

to connect tables (with connecting bolt 280563), as table extension and vertical superstructure, from 500 mm with mounting holes for table legs, from 1000 mm support through table leg required, can be used on foundation rail with leg 280371

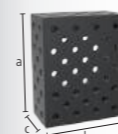

	L (a)	B (b)	H (c)	MS (d)	G	
2-280360.2.P	500 mm	400 mm	200 mm	25 mm	107 kg	892 £ •
2-280370.2.P	1000 mm	400 mm	200 mm	25 mm	188 kg	1.453 £ •
2-280374.2.P	1200 mm	400 mm	200 mm	25 mm	216 kg	2.053 £ •
2-280380.2.P	1500 mm	400 mm	200 mm	25 mm	260 kg	2.235 £ •
2-280390.2.P	2000 mm	400 mm	200 mm	25 mm	336 kg	2.666 £ •
2-280391.2.P	2400 mm	400 mm	200 mm	25 mm	392 kg	3.212 £ •
2-280392.2.P	3000 mm	400 mm	200 mm	25 mm	489 kg	3.950 £ •
2-280394.2.P	4000 mm	400 mm	200 mm	25 mm	641 kg	5.235 £ •

Square U-Shape 400x400 Plasma nitrided

to connect tables (with connecting bolt 280563), from 500 mm with mounting holes for table legs, from 1000 mm support through table leg required, can be used on foundation rail with leg 280371, Diagonal grid upon request

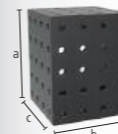

	L (a)	B (b)	H (c)	MS (d)	G	
2-280360.3.P	500 mm	400 mm	400 mm	25 mm	176 kg	1.373 £ •
2-280370.3.P	1000 mm	400 mm	400 mm	25 mm	295 kg	2.290 £ •
2-280374.3.P	1200 mm	400 mm	400 mm	25 mm	340 kg	2.599 £ •
2-280380.3.P	1500 mm	400 mm	400 mm	25 mm	414 kg	3.308 £ •
2-280390.3.P	2000 mm	400 mm	400 mm	25 mm	533 kg	4.021 £ •
2-280391.3.P	2400 mm	400 mm	400 mm	25 mm	622 kg	5.013 £ •
2-280392.3.P	3000 mm	400 mm	400 mm	25 mm	770 kg	6.043 £ •
2-280394.3.P	4000 mm	400 mm	400 mm	25 mm	1007 kg	8.196 £ •

Aluminum profile square

- Quickly ready for use thanks to clamping plates on the front ends
- Flexible mounting options thanks to integrated hexagonal slot
- Lightweight design for easy handling
- Ideal as a table extension or additional vertical clamping surface
- Cost-optimized through integrated components

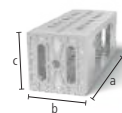

Aluminum profile square 500x200x200 with hexagonal slot

Clamping plate on both ends, with hexagonal slot HX14, as table extension and vertical clamping surface, from 1000 mm support through table leg required (2x Reduction Bushing 000546 required), Flatness tolerance < 0,9 mm / 1000 mm

NEW



	L (a)	B (b)	H (c)	G	
4-AQ28HX500	500 mm	200 mm	200 mm	10,20 kg	263 £ •
4-AQ28HX800	800 mm	200 mm	200 mm	14,30 kg	369 £ •
4-AQ28HX1000	1000 mm	200 mm	200 mm	17,20 kg	440 £ •
4-AQ28HX1200	1200 mm	200 mm	200 mm	19,50 kg	512 £ •
4-AQ28HX1500	1500 mm	200 mm	200 mm	23,90 kg	618 £ •
4-AQ28HX2000	2000 mm	200 mm	200 mm	30,90 kg	798 £ •

Sliding Blocks

Sliding Block HX14 Standard nitrided

with M12 thread, attachment of accessories with M12 screw, place it into the desired position by inserting it into the slot from the side



	L (a)	B (b)	H (c)	G	
2-HN280547	25 mm	30 mm	14 mm	0,06 kg	8 £ •

Sliding Block HX14 rotatable nitrided

attachment of accessories with M12 screw, enables placement in the slot from above, tensions in the slot when turning in the direction of fastening the screw



	L (a)	B (b)	H (c)	G	
2-HN280547.1	40 mm	30 mm	14 mm	0,04 kg	10 £ •

Sliding Block HX14 long nitrided

with M12 thread



	L (a)	B (b)	H (c)	G	
2-HN280547.2	40 mm	30 mm	14 mm	0,08 kg	10 £ •



You can find more information and accessories for these products online.



www.siegmund.com/
F-profile

Aluminum profile bracket

Aluminum profile bracket 200x50 mm (50 mm Grid)

Version with full grid with many clamping options, Requires Clamping Bolt without slot Triple, as table extension and vertical clamping surface, from 1000 mm support through table leg required (2x Reduction Bushing 000546 required)

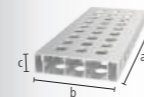

	L (a)	B (b)	H (c)	G	
4-AR28014050.V	500 mm	200 mm	50 mm	2,76 kg	57 £ •
4-AR28014080.V	800 mm	200 mm	50 mm	4,37 kg	89 £ •
4-AR28014100.V	1000 mm	200 mm	50 mm	5,44 kg	103 £ •
4-AR28014120.V	1200 mm	200 mm	50 mm	6,52 kg	125 £ •
4-AR28014150.V	1500 mm	200 mm	50 mm	8,13 kg	166 £ •
4-AR28014200.V	2000 mm	200 mm	50 mm	10,82 kg	206 £ •

Aluminum profile bracket 200x50 mm (50 mm Grid with elongated hole)

Variable clamping also possible at an angle, Requires Clamping Bolt without slot Triple, as table extension and vertical clamping surface, from 1000 mm support through table leg required (2x Reduction Bushing 000546 required)

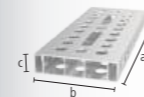

	L (a)	B (b)	H (c)	G	
4-AR28014050.VL	500 mm	200 mm	50 mm	2,69 kg	65 £ •
4-AR28014080.VL	800 mm	200 mm	50 mm	4,23 kg	101 £ •
4-AR28014100.VL	1000 mm	200 mm	50 mm	5,27 kg	118 £ •
4-AR28014120.VL	1200 mm	200 mm	50 mm	6,31 kg	144 £ •
4-AR28014150.VL	1500 mm	200 mm	50 mm	7,89 kg	188 £ •
4-AR28014200.VL	2000 mm	200 mm	50 mm	10,48 kg	237 £ •

Accessories

Adapter for screw clamps nitrided

for using screw clamps in aluminum profiles, for Screw Clamps: 280610.N, 280630.N, 280615.N, 280611.1, 280611.2



	L (a)	Ø	G	
2-AP280605.N basic	80 mm	45 mm	0,54 kg	15 £ •
2-AP280602.N double	105 mm	45 mm	0,65 kg	18 £ •

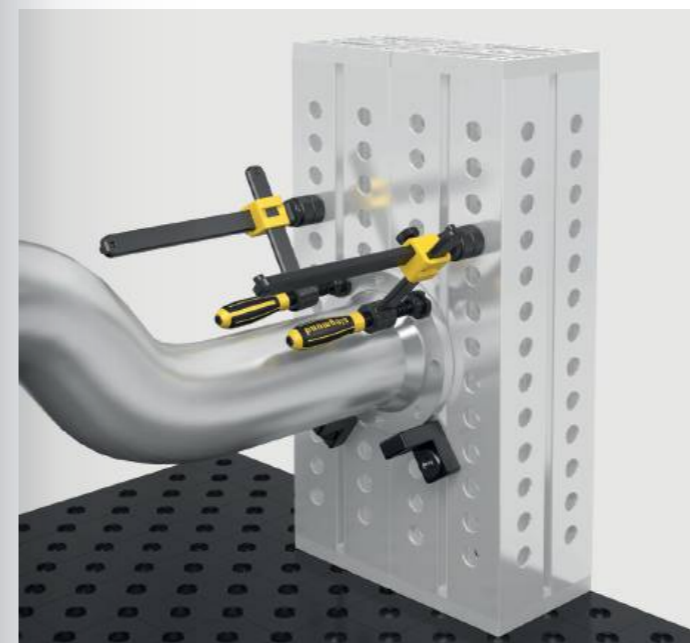



Areal Clamping Bolt burnished

280590: Clamping range approx. 47-53 mm, 280590.3: Clamping range approx. 72-78 mm, 280590.4: Clamping range approx. 97-103 mm, recommended for clamping aluminum profiles, MUST NOT be used for connecting tables and U-shaped squares

B 28

		L (a)	SK	ZK1	ZK	AM1	AM	G	
2-280590	double	100 mm	200 kN	6 kN	20 kN	20 Nm	50 Nm	0,56 kg	65 £ •
2-280590.3	triple	125 mm	200 kN	6 kN	20 kN	20 Nm	50 Nm	0,68 kg	69 £ •
2-280590.4	quadruple	150 mm	200 kN	6 kN	20 kN	20 Nm	50 Nm	0,80 kg	75 £ •



Areal Clamping Flush Mount Bolt burnished

countersunk connection of components, 280595: Clamping range approx. 47-53 mm, 280595.3: Clamping range approx. 72-78 mm, 280595.4: Clamping range approx. 97-103 mm, not suitable for elongated holes, MUST NOT be used for connecting tables and U-shaped squares

B 28

		L (a)	SK	ZK1	ZK	AM1	AM	G	
2-280595	double	65 mm	200 kN	6 kN	10 kN	20 Nm	50 Nm	0,29 kg	45 £ •
2-280595.3	triple	90 mm	200 kN	6 kN	10 kN	20 Nm	50 Nm	0,41 kg	51 £ •
2-280595.4	quadruple	115 mm	200 kN	6 kN	10 kN	20 Nm	50 Nm	0,52 kg	56 £ •



Fast Clamping Bolt without slot burnished

without O-ring slot for a smooth surface, MUST NOT be used for connecting tables and U-shaped squares

B 28

		L (a)	SK	ZK	AM1	AM	G	
2-280511	double	95 mm	220 kN	25 kN	10 Nm	25 Nm	0,54 kg	56 £ •
2-280513	triple	120 mm	220 kN	25 kN	10 Nm	25 Nm	0,65 kg	62 £ •
2-280515	quadruple	145 mm	220 kN	25 kN	10 Nm	25 Nm	0,76 kg	68 £ •



Flush Mount Bolt without slot burnished

countersunk connection of components, only for clamping aluminum profiles, tighten aluminum parts only hand-tight

B 28

		L (a)	SK	ZK	AM1	AM	G	
2-AP280528	double	65 mm	220 kN	3 kN	10 Nm	0,28 kg		36 £ •
2-AP280529	triple	92 mm	220 kN	3 kN	10 Nm	0,40 kg		43 £ •
2-AP280530	quadruple	117 mm	220 kN	3 kN	10 Nm	0,50 kg		50 £ •



Flush Mount Bolt Premium Light <-> Premium Light burnished

clamping of 2 components Premium Light (material thickness 15 mm), countersunk connection of components, not suitable for aluminum profiles, not suitable for elongated holes

B 28

		L (a)	Ø	SK	ZK	AM	G	
2-800528		46 mm	31 mm	220 kN	10 kN	25 Nm	0,20 kg	44 £ •



Flush Mount Bolt burnished

countersunk connection of components, MUST NOT be used for connecting tables and U-shaped squares, not suitable for aluminum profiles, not suitable for elongated holes

B 28

		L (a)	SK	ZK	AM	G	
2-280528	double	66 mm	220 kN	10 kN	25 Nm	0,30 kg	45 £ •
2-280529	triple	91 mm	220 kN	10 kN	25 Nm	0,41 kg	52 £ •



Connecting Bolt with collar burnished

to connect tables, U-squares and aluminum profiles, suitable for elongated holes, fixed long-term connection

B 28

		L (a)	SK	ZK	AM1	AM	G	
2-280583	double	70 mm	200 kN	15 kN	60 Nm	70 Nm	0,39 kg	28 £ •
2-280584	triple	95 mm	200 kN	15 kN	60 Nm	70 Nm	0,51 kg	33 £ •
2-280585	quadruple	120 mm	200 kN	15 kN	60 Nm	70 Nm	0,63 kg	39 £ •



Fast Clamping Bolt flat without slot burnished

minimal protrusion, MUST NOT be used for connecting tables and U-shaped squares, suitable for aluminum profiles, suitable for elongated holes

B 28

		L (a)	SK	ZK	AM1	AM	G	
2-280524	double	74 mm	220 kN	25 kN	10 Nm	25 Nm	0,36 kg	50 £ •
2-280525	triple	99 mm	220 kN	25 kN	10 Nm	25 Nm	0,42 kg	56 £ •



Fast Clamping Bolt adjustable without slot burnished

280571: Clamping range approx. 25-50 mm, 280573: Clamping range approx. 50-75 mm, clamping of customized laser cut profiles, suitable for aluminum profiles, tighten aluminum parts only hand-tight, MUST NOT be used for connecting tables and U-shaped squares

100 B 28

		L (a)	SK	ZK	AM1	AM	G	
2-280571	double	115 mm	220 kN	25 kN	10 Nm	25 Nm	0,67 kg	62 £ •
2-280573	triple	140 mm	220 kN	25 kN	10 Nm	25 Nm	0,83 kg	76 £ •



Universal Bolt Comfort burnished

280532: Clamping range approx. 45-53 mm, 280533: Clamping range approx. 70-78 mm, MUST NOT be used for connecting tables and U-shaped squares

B 28

		L (a)	SK	ZK	AM1	AM	G	
2-280532	double	100 mm	200 kN	25 kN	10 Nm	25 Nm	0,60 kg	59 £ •
2-280533	triple	125 mm	200 kN	25 kN	10 Nm	25 Nm	0,70 kg	66 £ •

Style: double / triple / quadruple



You can find more information and accessories for these products online.



www.siegmund.com/
F-bolt28



Connecting Bolt XL / Siegmund Light <-> Siegmund Light burnished

to connect Siegmund Light products (15 mm material thickness), not suitable for aluminum profiles, fixed long-term connection, hardened

NEW



	L (a)	SK	ZK	AM	G	
2-800563	52 mm	200 kN	20 kN	420 Nm	0,29 kg	23 £ •

Connecting Bolt XL / Siegmund <-> Siegmund Light burnished

to connect Siegmund and Siegmund Light (25 mm and 15 mm material thickness), not suitable for aluminum profiles, fixed long-term connection, hardened

NEW



	L (a)	SK	ZK	AM	G	
2-800564	62 mm	200 kN	20 kN	420 Nm	0,32 kg	23 £ •

Connecting Bolt XL burnished

to connect tables and U-squares, not suitable for aluminum profiles, not suitable for elongated holes, fixed long-term connection, hardened

NEW



	L (a)	SK	ZK	AM	G	
2-280563	double	200 kN	20 kN	420 Nm	0,35 kg	23 £ •
2-280564	triple	200 kN	20 kN	420 Nm	0,44 kg	29 £ •



Fast Clamping Bolt with handle burnished

clamping without the use of tools, Clamping range 33-60 mm, MUST NOT be used for connecting tables and U-shaped squares

B 28

	L (a)	SK	ZK	G	
2-280516	235 mm	220 kN	25 kN	0,63 kg	73 £ •



Positioning Bolt burnished

substitutes a second clamping bolt cost-effectively, MUST NOT be used for connecting tables and U-shaped squares

B 28

	L (a)	G	
2-280540	70 mm	0,40 kg	15 £ •



Universal Bolt Basic burnished

280536: Clamping range approx. 42-57 mm, 280537: Clamping range approx. 67-82 mm, MUST NOT be used for connecting tables and U-shaped squares, clean boreholes before use, not suitable for aluminum profiles

B 28

		L (a)	SK	ZK	AM	G	
2-280536	double	84 mm	200 kN	25 kN	25 Nm	0,43 kg	48 £ •
2-280537	triple	108 mm	200 kN	25 kN	25 Nm	0,55 kg	54 £ •



Magnetic Clamping Bolt Aluminum

clamping without the use of tools, suitable for pressure-sensitive parts or when counterholding is not possible

AL 28

		HK	L (a)	SF	G	
2-280740		0,18 kN	68 mm	25 mm	0,09 kg	29 £ •
2-280740.1		0,18 kN	93 mm	50 mm	0,13 kg	34 £ •
2-280740.2		0,18 kN	118 mm	75 mm	0,16 kg	40 £ •

Spacer Ring for Magnetic Bolt burnished

distance between two clamping elements

B 28



	L (a)	G	
2-280741	25 mm	0,12 kg	8 £ •



Spacer Ring for Premium Light pack of 4 nitrided

distance between two clamping elements, is required for clamping to material thickness 15 mm with bolt 280511, Scope of delivery: 4 pieces

BAR N 28

	MS (d)	G	
2-800653.1.N	10 mm	0,04 kg	10 £ •





Professional Screw Clamp nitrided

interchangeable prism, ball diameter spindle 16 mm, Trapezoid thread of spindle 20x4 mm, Vertical Bar reinforced



2-280610.N

SP	B (b)	H (c)	G
5 kN	220 mm	310 mm	2,39 kg

84 £ •



Professional Screw Clamp XL nitrided

interchangeable prism, ball diameter spindle 16 mm, Trapezoid thread of spindle 20x4 mm, Vertical Bar reinforced



2-280612.N

SP	B (b)	H (c)	G
7 kN	220 mm	310 mm	3,52 kg

96 £ •



Professional Screw Clamp 45°/90° nitrided

interchangeable prism, ball diameter spindle 16 mm, Trapezoid thread of spindle 20x4 mm, stepless rotation from 0-360°, Vertical Bar reinforced



2-280630.N

SP	H (c)	G
5 kN	310 mm	2,84 kg

78 £ •



Professional Fast Tension Clamp nitrided

Vertical Bar reinforced



2-280615.N

SP	B (b)	H (c)	G
5 kN	275 mm	310 mm	2,62 kg

108 £ •



Basic Pipe Clamp 180° burnished / nitrided

interchangeable prism, ball diameter spindle 16 mm, Trapezoid thread of spindle 20x4 mm, clamping at a 180° angle, fastening with an adjusting ring



2-280625

SP	B (b)	H (c)	G
3 kN	220 mm	250 mm	2,28 kg

70 £ •



Pipe Clamp Universal burnished / nitrided

interchangeable prism, ball diameter spindle 16 mm, Trapezoid thread of spindle 20x4 mm, clamping at an angle of +/- 42°, fastening with an adjusting ring



2-280604

SP	B (b)	H (c)	G
3 kN	265 mm	250 mm	2,57 kg

85 £ •

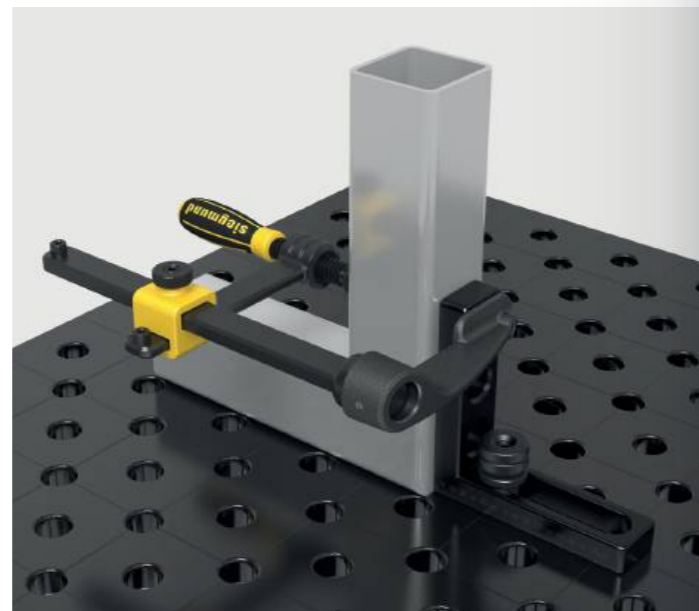

Basic Pipe Clamp 90° nitrided

interchangeable prism, ball diameter spindle 16 mm, clamping at an angle of 90°, Trapezoid thread of spindle 20x4 mm, stepless rotation from 0-360°, fastening with an adjusting ring



2-280608.N

SP	H (c)	G
3 kN	230 mm	1,42 kg

57 £ •



Vertical Toggle Clamp

for Screw Clamps: 280611.1, 280611.2, usable in borehole with thread bushing 280618.N, Trapezoid thread of spindle 20x4 mm



2-009902.1

H (c)	G
85 mm	0,88 kg

81 £ •



Professional Screw Clamp with vertical action toggle

interchangeable prism, ball diameter spindle 16 mm, Trapezoid thread of spindle 20x4 mm, Vertical Bar reinforced



2-280611.1

SP	B (b)	H (c)	G
2,50 kN	222 mm	310 mm	2,86 kg

118 £ •



Professional Screw Clamp 45°/90° with vertical action toggle

interchangeable prism, ball diameter spindle 16 mm, Trapezoid thread of spindle 20x4 mm, Vertical Bar reinforced



2-280611.2

SP	H (c)	G
2,50 kN	310 mm	2,50 kg

116 £ •



Extension for clamps nitrided

Compatible with: 280604, 280610.N, 280611.1, 280615.N, 280625



2-280680.N

L (a)	B (b)	H (c)	G
206 mm	66 mm	45 mm	0,98 kg

20 £ •



Fast Tension Clamp, Standard

clamping independent of borehole grid



2-280616

L (a)	B (b)	G
200 mm	100 mm	1,39 kg

68 £ •

2-280616.1

250 mm	120 mm	1,56 kg
--------	--------	---------

78 £ •

2-280616.2

300 mm	140 mm	2,29 kg
--------	--------	---------

92 £ •

2-280616.3

400 mm	120 mm	2,47 kg
--------	--------	---------

98 £ •

Quick-Change Clamp 100

Length clamping arm 100 mm, Clamping range 0-100 mm, Mounting in system boreholes



	L (a)	B (b)	H (c)	G	
2-280706	340 mm	30 mm	150 mm	1 kg	70 £ •

Quick-Change Clamp 160

Length clamping arm 160 mm, Clamping range 0-140 mm, Mounting in system boreholes



	L (a)	B (b)	H (c)	G	
2-280707	360 mm	30 mm	150 mm	1,10 kg	70 £ •

Vertical clamp 1800 with Adapter

Adapter CS280715.4, for system borehole 28 mm



	SP	G	Special offer price
4-CS280790	1,80 kN	0,91 kg	53 £ •
			instead of 57 £

Vertical clamp 2200 with Adapter

Adapter CS280715.4, for system borehole 28 mm



	SP	G	Special offer price
4-CS280791	2,20 kN	1,18 kg	57 £ •
			instead of 61 £

Horizontal clamp 1800 with Adapter

Adapter CS280715.4, for system borehole 28 mm



	SP	G	Special offer price
4-CS280794	1,80 kN	0,91 kg	51 £ •
			instead of 54 £

Horizontal clamp 3000 with Adapter

Adapter CS280715.4, for system borehole 28 mm



	SP	G	Special offer price
4-CS280795	3 kN	1,21 kg	58 £ •
			instead of 62 £

Horizontal Toggle Clamp 2500 with Adapter

Adapter CS280715.4, for system borehole 28 mm



	SP	G	Special offer price
4-CS280792	2,50 kN	0,99 kg	65 £ •
			instead of 69 £

Horizontal Toggle Clamp 4000 with Adapter

Adapter CS280715.4, for system borehole 28 mm



	SP	G	Special offer price
4-CS280793	4 kN	1,48 kg	81 £ •
			instead of 87 £



You can find more information and accessories for these products online.



www.siegmund.com/
F-clamp28

Thread Bushing Tr 20x4 nitrided

for 280610.N, 280612.N, 280625, 280611.1, Acme trapezoidal thread 20x4 mm for system 28 screw clamp arbor, usable in every system borehole



	H (c)	Ø	G	
2-280618.N	22 mm	30 mm	0,04 kg	8 £ •

Thread Bushing Tr 12x3 burnished

Acme trapezoidal thread 12x3 mm for system 16 screw clamp arbor, usable in every system borehole



	H (c)	Ø	G	
2-280619	23 mm	32 mm	0,09 kg	10 £ •

Prism for Screw Clamps

for spindle with ball diameter 16 mm



	H (c)	Ø	G	
2-280657.1.N	24 mm	40 mm	0,10 kg	11 £ •
2-280658.E	21 mm	40 mm	0,09 kg	15 £ •
2-280659.PA	24 mm	40 mm	0,01 kg	13 £ •
2-280657.1.AE	28 mm	40 mm	0,07 kg	20 £ •

Pressure Ball for Screw Clamps

for spindle with ball diameter 16 mm, only suitable for clamps, for clamping in corners or grooves



	H (c)	Ø	G	
2-280660	20 mm	35 mm	0,07 kg	11 £ •
2-280660.E	20 mm	35 mm	0,08 kg	15 £ •
2-280660.PA	20 mm	35 mm	0,01 kg	13 £ •

Pressure Ball Blank for Screw Clamps Polished

for spindle with ball diameter 16 mm, compatible with 28 mm boreholes and clamps, as specified by customer



	H (c)	Ø	G	
2-280661	30 mm	40 mm	0,19 kg	15 £ •

Duo Prism Ø 40

for spindle with ball diameter 16 mm



	H (c)	Ø	G	
2-280650	35 mm	40 mm	0,17 kg	22 £ •
2-280650.A	35 mm	40 mm	0,09 kg	24 £ •
2-280650.PA	35 mm	40 mm	0,02 kg	24 £ •

Clamping Bridge 2P for Screw Clamps

2 clamping spots simultaneously, interchangeable prism, Delivery includes: 1 clamping bridge, 2 ball pins, 2 prisms



	L (a)	B (b)	H (c)	G	
2-280210	170 mm	35 mm	20 mm	0,51 kg	53 £ •

Clamping Bridge 3P for Screw Clamps

3 clamping points simultaneously, interchangeable prism, Delivery includes: 1 clamping bridge, 3 ball pins, 3 prisms



	L (a)	B (b)	H (c)	G	
2-280211	170 mm	35 mm	20 mm	0,58 kg	66 £ •



Prism Ø 50 135° with screwed-in collar
M16 thread for e.g. prism extensions Item No. 280649, for pipes up to Ø 80 mm

		H (c)	Ø	G	
2-280648.1.N	28 IN BAR	20 mm	50 mm	0,20 kg	31 £ •
2-280648.1.A	28 AL	20 mm	50 mm	0,07 kg	36 £ •
2-280648.1.PA	28 PA	20 mm	50 mm	0,03 kg	40 £ •



Vario Prism Ø 50 90° / 120° with screwed-in collar
M16 thread for e.g. prism extensions Item No. 280649, for round and square pipes up to Ø 50 mm

		H (c)	Ø	G	
2-280645.1	28 B	20 mm	50 mm	0,20 kg	34 £ •
2-280645.1.A	28 AL	20 mm	50 mm	0,07 kg	40 £ •
2-280645.1.PA	28 PA	20 mm	50 mm	0,03 kg	42 £ •



Prism Ø 60 135° with screwed-in collar
M16 thread for e.g. prism extensions Item No. 280649, for pipes up to Ø 80 mm

		H (c)	Ø	G	
2-280651.1.N	28 IN BAR	30 mm	60 mm	0,52 kg	34 £ •
2-280651.1.A	28 AL	30 mm	60 mm	0,18 kg	40 £ •
2-280651.1.PA	28 PA	30 mm	60 mm	0,08 kg	42 £ •



Prism Ø 80 90° with screwed-in collar
M16 thread for e.g. prism extensions Item No. 280649, for round and square pipes up to Ø 100 mm

		H (c)	Ø	G	
2-280647.1	28 B	40 mm	80 mm	1,01 kg	42 £ •
2-280647.1.A	28 AL	40 mm	80 mm	0,55 kg	48 £ •
2-280647.1.PA	28 PA	40 mm	80 mm	0,19 kg	51 £ •

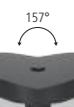

Prism Ø 120 157° with screwed-in collar
M16 thread for e.g. prism extensions Item No. 280649, for pipes up to Ø 400 mm

		H (c)	Ø	G	
2-280652.1	28 B	30 mm	120 mm	1,70 kg	58 £ •
2-280652.1.A	28 AL	30 mm	120 mm	0,70 kg	70 £ •
2-280652.1.PA	28 PA	30 mm	120 mm	0,30 kg	79 £ •

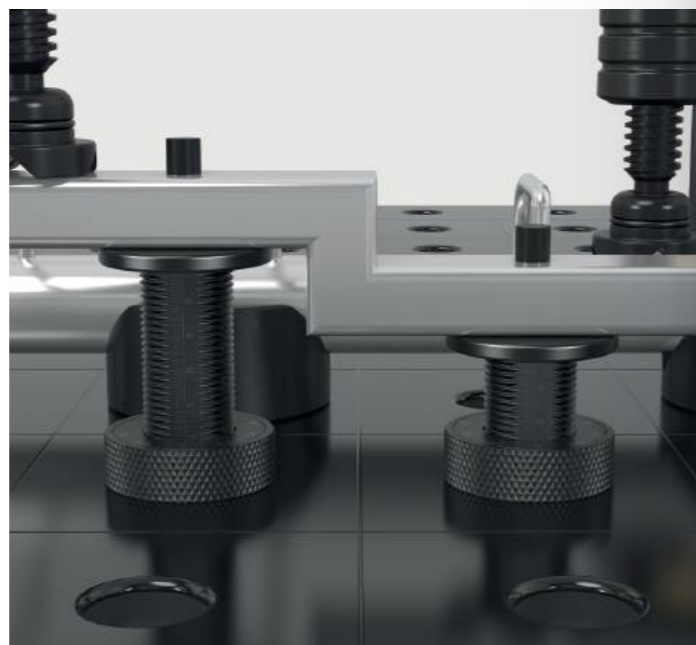

Clamping Cone burnished
for holding round and square pipes up to Ø 80 mm, clamping with bolts

	H (c)	Ø	G	
2-280670	70 mm	80 mm	1,40 kg	39 £ •



Screw Support Ø 80 burnished
vernier adjustment height in a range of 75-110 mm, combinable with support set 280821 and prism extensions

	H (c)	Ø	G	
2-280822	75-110 mm	80 mm	2,30 kg	87 £ •



Support height adjustable with scale burnished
incl. Set screw, height infinite adjustable between 20-105 mm, Set screw for connecting with prisms

	H (c)	Ø	G	
2-280824	144 mm	50 mm	0,87 kg	53 £ •

Prism Collar Screw with countersunk bolt nitrided
to mount prisms in boreholes



	L (a)	Ø	G	
2-280669.N	17 mm	28 mm	0,14 kg	11 £ •

Prism Extension burnished
compatible with prisms, support set 280821 and screw support 280822



	L (a)	Ø	G	
2-280649	25 mm	28 mm	0,11 kg	14 £ •
2-280649.1	50 mm	28 mm	0,22 kg	17 £ •
2-280649.2	100 mm	28 mm	0,45 kg	20 £ •
2-280649.3	150 mm	28 mm	0,69 kg	26 £ •

Set of Supports 11 pieces burnished
compensation of 1-100 mm height difference, with M10 thread



	L (a)	Ø	G	
2-280821	125 mm	50 mm	1,95 kg	57 £ •

Tower for Supports burnished
variable support surface, with M10 thread



	L (a)	Ø	G	
2-280821.1	125 mm	50 mm	0,60 kg	29 £ •

Washer Set
gradation of discs: 1 / 2 / 3 / 4 / 5 / 10 / 20 / 40 / 50 mm incl. 1/10" disc 2,54 mm



	Ø	G	
2-280821.2	50 mm	1,35 kg	29 £ •

Thread Bushing for M16 thread burnished
for Spacer



	H (c)	Ø	G	
2-280825	23 mm	30 mm	0,07 kg	17 £ •

Spacer 100
with thread bushing 280825 adaptable in squares and stops, M16 thread



	L (a)	Ø	G	
2-280175	100 mm	50 mm	0,52 kg	43 £ •
2-280176	100 mm	75 mm	0,92 kg	48 £ •
2-280177	100 mm	100 mm	1,42 kg	52 £ •

Spacer 150
with thread bushing 280825 adaptable in squares and stops, M16 thread



	L (a)	Ø	G	
2-280175.1	150 mm	50 mm	0,60 kg	45 £ •
2-280176.1	150 mm	75 mm	1 kg	50 £ •
2-280177.1	150 mm	100 mm	1,50 kg	54 £ •

Vertical Pipe
for Multi Clamp Tower modular



	H (c)	Ø	G	
2-280646.1	225 mm	57 mm	1,63 kg	58 £ •
2-280646.2	475 mm	57 mm	2,93 kg	66 £ •
2-280646.3	725 mm	57 mm	4,24 kg	74 £ •
2-280646.4	975 mm	57 mm	5,53 kg	85 £ •

Plate small / large
for Multi Clamp Tower modular



	L (a)	B (b)	H (c)	G	
2-280646	120 mm	120 mm	25 mm	2,22 kg	29 £ •
2-280646.5	150 mm	100 mm	25 mm	2,59 kg	44 £ •

Cast Iron Cross incl. Handwheel
for Multi Clamp Tower modular, Compatible horizontal bars: 280638.N, 280638.1.N, 280638.2.N



	L (a)	B (b)	H (c)	G	
2-280617.5H	104 mm	80 mm	56 mm	1,35 kg	35 £ •

For a clamping tower, you will need the following parts:

1. Vertical Pipe (280646.1 / 280646.2 / 280646.3 / 280646.4)
2. Plate for Multi Clamp Tower modular (280646 / 280646.5)
3. Cast Iron Cross incl. Handwheel (280617.5H)
4. Horizontal Bar (280638.N / 280638.1.N / 280638.2.N)
5. Thread Bushing (280618.N)
6. Arbor (280634.N / 280634.1.N / 280634.2.N / 280635.N / 280635.1.N / 280635.2.N / 280636.N / 280636.1.N / 280636.2.N)
7. Prism for Screw Clamps (280657.1.N / 280657.1.AE / 280657.1.E / 280659.PA / ...)



You can find more information and accessories for these products online.



www.siegmund.com/
F-prism28

Basic

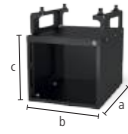

Sub Table Box lockable for Basic

powder coated finish, Storage space at your welding table, 360 mm space for drawers, lockable, incl. two keys

28

	L (a)	B (b)	H (c)	TF	G	
2-281990	630 mm	485 mm	430 mm	100 kg	31 kg	386 £ •



Set Sub Table Box lockable for Basic incl. 2 drawers

incl. drawers (2x 004230), powder coated finish, Storage space at your welding table, lockable, incl. two keys, delivered pre-assembled, drawer pull-out length 500 mm

28

	L (a)	B (b)	H (c)	TF	G	Special offer price
2-281990.1	630 mm	485 mm	430 mm	100 kg	45 kg	548 £ • instead of 554 £



Set Sub Table Box lockable for Basic incl. 3 drawers

incl. drawers (1x 004220, 1x 004225, 1x 004230), powder coated finish, Storage space at your welding table, lockable, incl. two keys, delivered pre-assembled, drawer pull-out length 500 mm

28

	L (a)	B (b)	H (c)	TF	G	Special offer price
2-281990.2	630 mm	485 mm	430 mm	100 kg	50 kg	601 £ • instead of 616 £



You can find more information and accessories for these products online.



www.siegmund.com/
F-stbox

Professional 750 / Extreme 8.7 / Extreme 8.8 PLUS

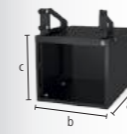

Sub Table Box lockable

powder coated finish, Storage space at your welding table, 360 mm space for drawers, lockable, incl. two keys, Compatible with PLUS tables

28

	L (a)	B (b)	H (c)	TF	G	
2-280990	630 mm	485 mm	430 mm	100 kg	30 kg	386 £ •



Set Sub Table Box lockable incl. 2 drawers

incl. drawers (2x 004230), powder coated finish, Storage space at your welding table, lockable, incl. two keys, Compatible with PLUS tables, delivered pre-assembled, drawer pull-out length 500 mm

28

	L (a)	B (b)	H (c)	TF	G	Special offer price
2-280990.1	630 mm	485 mm	430 mm	100 kg	44 kg	548 £ • instead of 554 £



Set Sub Table Box lockable incl. 3 drawers

incl. drawers (1x 004220, 1x 004225, 1x 004230), powder coated finish, Storage space at your welding table, lockable, incl. two keys, Compatible with PLUS tables, delivered pre-assembled, drawer pull-out length 500 mm

28

	L (a)	B (b)	H (c)	TF	G	Special offer price
2-280990.2	630 mm	485 mm	430 mm	100 kg	49 kg	601 £ • instead of 616 £

Configuration

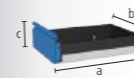

Drawer with clip rail

powder coated finish, upgrading possible at any time, for Sub Table Box, for Workstation 0806 / 1208 / 1212 with side walls

16 22 28

	L (a)	B (b)	H (c)	TF	G	
2-004220	590 mm	400 mm	60 mm	50 kg	5,50 kg	69 £ •
2-004225	590 mm	400 mm	120 mm	50 kg	6,50 kg	77 £ •
2-004230	590 mm	400 mm	180 mm	50 kg	7 kg	85 £ •
2-004235	590 mm	400 mm	240 mm	50 kg	7,50 kg	92 £ •



Bench vice 125



Siegmund bench vice 125

Fastening at a 45° or 90° angle, Jaw width 125 mm, Opening stroke 125 mm, Mounting: System 16: 2x 160511 + 2x 000546, System 22: 2x 220513 + 2x 000544, System 28: 2x 280511

16 22 28

	SP	G	
2-004320	30 kN	17,50 kg	266 £ •



Set of vice jaw covers 125 incl. bag

Delivery contents: 2x Fiber, 2x Rubber, 2x Aluminum neutral, 2x Aluminum prisms

16 22 28

	G	
2-004325	0,85 kg	59 £ •



Set Siegmund bench vice 125 System 28

Fastening at a 45° or 90° angle, Jaw width 125 mm, Opening stroke 125 mm, Delivery contents: 1x Bench vice 004320, 2x Bolt 280511, 1x Set of vice jaw covers 004325

28

	SP	G	
2-284320	30 kN	19,43 kg	407 £ •

Bench vice 150



Siegmund bench vice 150

Fastening at a 45° or 90° angle, Jaw width 150 mm, Opening stroke 150 mm, Mounting: System 16: 2x 160511 + 2x 000546, System 22: 2x 220513 + 2x 000544, System 28: 2x 280511

16 22 28

	SP	G	
2-004330	40 kN	24 kg	345 £ •



Set of vice jaw covers 150 incl. bag

Delivery contents: 2x Fiber, 2x Rubber, 2x Aluminum neutral, 2x Aluminum prisms

16 22 28

	G	
2-004335	1 kg	67 £ •



Set Siegmund bench vice 150 System 28

Fastening at a 45° or 90° angle, Jaw width 150 mm, Opening stroke 150 mm, Delivery contents: 1x Bench vice 004330, 2x Bolt 280511, 1x Set of vice jaw covers 004335

28

	SP	G	
2-284330	40 kN	26,08 kg	488 £ •



Vice jaw covers

The basic body of the vice jaw covers consists of solid aluminum profiles. The integrated magnets in the profiles hold the covers reliably on the vice and enable quick and easy changing, depending on the workpiece or processing step. Despite the very high magnetic force, workpieces are not magnetized. The vice jaw covers are right-angled and plane-parallel, which means that the high level of accuracy of the Siegmund vice keeps retained.

Set of vice jaw covers

2x Fiber: suitable for finely milled, finely planed, ground or polished surfaces, 2x Rubber: suitable for wooden and plastic parts, 2x Aluminum neutral: secure clamping of coarse to medium-fine machined workpieces thanks to grooves, 2x Aluminum prisms: Clamping of round or oval workpieces using prisms



You can find more information and accessories for these products online.



www.siegmund.com/
F-benchvice

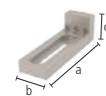

Table press System 28

compressive force of 2,5 tons, total stroke 60 mm, operating force 330 N, fixation always required in two places

28

	G	
2-280780	6,70 kg	1.180 £ •



Special Square System 28

as an extension and vertical fixation of the press

28

	L (a)	B (b)	H (c)	G	
2-280702	195 mm	60 mm	60 mm	1,87 kg	107 £ •

Thrust Piece

000701.AL: recommended for steel work, 000701.PA: recommended for applications with stainless steel



	H (c)	Ø	G	
2-000701.AL	15 mm	55 mm	0,08 kg	24 £ •
2-000701.PA	15 mm	55 mm	0,03 kg	20 £ •



Stamp 90° with extention pipe

for pressing in corners without damaging the weld seam

16 22 28

	L (a)	B (b)	H (c)	G	
2-000706	168 mm	50 mm	50 mm	0,82 kg	103 £ •



Pipe Adapter POM-C

for straightening pipes, for pipes Ø 21,4 mm: 000703.1, for pipes Ø 26,9 mm: 000703.4, for pipes Ø 33,7 mm: 000703.2, for pipes Ø 42,4 mm: 000703.3

16 22 28

	L (a)	Ø	G	
2-000703.1	35 mm	55 mm	0,08 kg	23 £ •
2-000703.4	35 mm	55 mm	0,08 kg	23 £ •
2-000703.2	35 mm	55 mm	0,08 kg	23 £ •
2-000703.3	35 mm	55 mm	0,07 kg	23 £ •



Pipe Bending Plug POM-C

for bending and straightening pipes, for pipes Ø 21,4 mm: 000704.1, for pipes Ø 26,9 mm: 000704.4, for pipes Ø 33,7 mm: 000704.2, for pipes Ø 42,4 mm: 000704.3

16 22 28

	L (a)	B (b)	H (c)	G	
2-000704.1	120 mm	35 mm	60 mm	0,25 kg	42 £ •
2-000704.4	120 mm	35 mm	60 mm	0,26 kg	42 £ •
2-000704.2	120 mm	35 mm	60 mm	0,25 kg	42 £ •
2-000704.3	120 mm	35 mm	60 mm	0,23 kg	42 £ •



Counter block POM-C

as a counter block for bending and straightening pipes, Plug socket required for fastening, fastened with bolt 160515 / 220515 / 280513 (not included in the delivery), for pipes Ø 21,4 mm: 000705.1, for pipes Ø 26,9 mm: 000705.4, for pipes Ø 33,7 mm: 000705.2, for pipes Ø 42,4 mm: 000705.3

16 22 28

	L (a)	B (b)	H (c)	G	
2-000705.1	60 mm	114 mm	55 mm	0,37 kg	54 £ •
2-000705.4	60 mm	111 mm	55 mm	0,35 kg	53 £ •
2-000705.2	60 mm	102 mm	55 mm	0,31 kg	52 £ •
2-000705.3	60 mm	93 mm	55 mm	0,27 kg	48 £ •



Plug socket

for rotatable fastening of the counter block in the boreholes, for fixing: 280513

28

	L (a)	Ø	G	
2-280701	50 mm	40 mm	0,11 kg	23 £ •

Product recommendation



Basic-Set

Included in the set: 1x 000701.PA, 1x 000701.AL, 1x 280702

28

	G	Special offer price
2-280783	1,98 kg	120 £ •
		instead of 151 £



Pipe straightening set for Ø 21,4

Included in the set: 1x 000703.1, 1x 000704.1, 2x 000705.1, 2x 280701, fastened with bolt 280513 (not included in the delivery)

28

	G	Special offer price
2-280782.1	1,29 kg	175 £ •
		instead of 219 £



Pipe straightening set for Ø 26,9

Included in the set: 1x 000703.4, 1x 000704.4, 2x 000705.4, 2x 280701, fastened with bolt 280513 (not included in the delivery)

28

	G	Special offer price
2-280782.4	1,26 kg	174 £ •
		instead of 217 £



Pipe straightening set for Ø 33,7

Included in the set: 1x 000703.2, 1x 000704.2, 2x 000705.2, 2x 280701, fastened with bolt 280513 (not included in the delivery)

28

	G	Special offer price
2-280782.2	1,17 kg	171 £ •
		instead of 213 £



Pipe straightening set for Ø 42,4

Included in the set: 1x 000703.3, 1x 000704.3, 2x 000705.3, 2x 280701, fastened with bolt 280513 (not included in the delivery)

28

	G	Special offer price
2-280782.3	1,06 kg	165 £ •
		instead of 206 £



You can find more information and accessories for these products online.



www.siegmund.com/
F-tablepress

Rail System Standard

- uniform track width
- 3 table sizes
- 1 connecting frame
- Hardened and rust-protected rails
- effortless positioning on the rail
- can be delivered quickly as all items are in stock as standard
- Above-floor and underfloor installation possible
- structured workspace with many clamping options
- System 16 / System 22: upon request

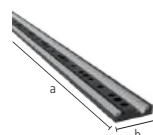

Foundation rail with round rail Plasma nitrided

Hardened and rust-protected rails, Above-floor and underfloor installation possible



	L (a)	B (b)	H (c)	G	
2-RSR2000.P	2000 mm	160 mm	40 mm	80 kg	1.179 £ •
2-RSR3000.P	3000 mm	160 mm	40 mm	120 kg	1.690 £ •



Connecting Frame SB 1800x900 with inserted Roller

Standard frame for table tops with track width 1800x900, caster can be repositioned depending on the direction of movement, connection of table top and connection frame with 4x 280528, fastening to the rail with 2x 280511

	L (a)	B (b)	H (c)	G	
2-RSF200	1970 mm	998 mm	200 mm	77 kg	2.343 £ •
2-RSF650	1970 mm	998 mm	650 mm	135 kg	2.643 £ •



Professional Extreme 8.7 table top SB 1800x900

only compatible with connecting frame SB 1800x900



	L (a)	B (b)	H (c)	G	
2-RST2820.XD7D	2000 mm	1000 mm	200 mm	665 kg	5.030 £ •
2-RST2830.XD7D	2400 mm	1200 mm	200 mm	950 kg	6.477 £ •
2-RST2840.XD7D	3000 mm	1500 mm	200 mm	1475 kg	9.284 £ •

New rail system

With our standard rail system, there is just one connecting frame with the same track width, regardless of the chosen table size.



Square U-Shape SB 1800

Square U-Shape 200x200 SB 1800 Plasma nitrided

with footplates for track width 1800



	L (a)	B (b)	H (c)	MS (d)	G	
2-RSU2000.P	2000 mm	200 mm	200 mm	25 mm	228 kg	1.706 £ •
2-RSU2400.P	2400 mm	200 mm	200 mm	25 mm	271 kg	2.094 £ •
2-RSU3000.P	3000 mm	200 mm	200 mm	25 mm	339 kg	2.625 £ •

Square U-Shape 400x200 SB 1800 Plasma nitrided

with footplates for track width 1800



	L (a)	B (b)	H (c)	MS (d)	G	
2-RSU2000W.P	2000 mm	400 mm	200 mm	25 mm	336 kg	2.666 £ •
2-RSU2400W.P	2400 mm	400 mm	200 mm	25 mm	396 kg	3.212 £ •
2-RSU3000W.P	3000 mm	400 mm	200 mm	25 mm	496 kg	3.950 £ •

Square U-Shape SB 900

Square U-Shape 200x200 SB 900 Plasma nitrided

with footplates for track width 900



	L (a)	B (b)	H (c)	MS (d)	G	
2-280370.P	1000 mm	200 mm	200 mm	25 mm	120 kg	969 £ •
2-RSU1200.P	1200 mm	200 mm	200 mm	25 mm	142 kg	1.207 £ •
2-RSU1500.P	1500 mm	200 mm	200 mm	25 mm	174 kg	1.381 £ •

Square U-Shape 400x200 SB 900 Plasma nitrided

with footplates for track width 900



	L (a)	B (b)	H (c)	MS (d)	G	
2-280370.2.P	1000 mm	400 mm	200 mm	25 mm	188 kg	1.453 £ •
2-RSU1200W.P	1200 mm	400 mm	200 mm	25 mm	211 kg	2.053 £ •
2-RSU1500W.P	1500 mm	400 mm	200 mm	25 mm	258 kg	2.235 £ •





Leg with inserted roller



Leg with inserted roller for Square U-shape 200x200

connection of U-Square and leg with inserted roller with 2x 280528, fastening to the rail with 2x 280513, with tilt protection

	L (a)	B (b)	H (c)	G	
2-RSUF200	196 mm	138 mm	200 mm	14,50 kg	840 £ •
2-RSUF650	196 mm	138 mm	650 mm	21,50 kg	955 £ •



Leg with inserted roller for Square U-shape 400x200

connection of U-Square and leg with inserted roller with 2x 280528, fastening to the rail with 2x 280513, with tilt protection

	L (a)	B (b)	H (c)	G	
2-RSUF200W	396 mm	138 mm	200 mm	30 kg	1.019 £ •
2-RSUF650W	396 mm	138 mm	650 mm	43 kg	1.120 £ •



Product recommendation



Stopping bolt for rail system burnished

with rubber buffer, is attached to the ends of the support and foundation rails, prevents driving out of the round rail and limits the travel distance, flat design for minimal interfering contour

	L (a)	G	
2-280241	45 mm	0,30 kg	15 £ •



Flush Mount Bolt burnished

countersunk connection of components, MUST NOT be used for connecting tables and U-shaped squares, not suitable for aluminum profiles, not suitable for elongated holes

	L (a)	SK	ZK	AM	G	
2-280528	66 mm	220 kN	10 kN	25 Nm	0,30 kg	45 £ •



Fast Clamping Bolt without slot burnished

without O-ring slot for a smooth surface, MUST NOT be used for connecting tables and U-shaped squares

	L (a)	SK	ZK	AM1	AM	G	
2-280511	95 mm	220 kN	25 kN	10 Nm	25 Nm	0,54 kg	56 £ •
2-280513	120 mm	220 kN	25 kN	10 Nm	25 Nm	0,65 kg	62 £ •



You can find more information and accessories for these products online.



www.siegmund.com/
F-railsystem

GENERAL PURPOSE FABRICATION

We recommend our System 22 for fine details to medium-heavy fabrications.
For everyone who cannot decide.

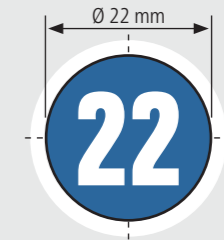

**Recommended load
up to 3000 kg**
max. 1500 kg per leg basic equipment

Load depends on the type and amount of table legs. The individual components are significantly higher. Based on our experience, we recommend the specified loads for your safety.

Professional 750

- premium steel S355J2+N, plasma nitrided and BAR-coated
- Material thickness approx. 17 – 19 mm
- Borehole Ø 22 mm, Boreholes on the surface 100x100 mm grid
- Height of table side 150 mm, Borehole spacing of table side 50 mm
- incl. leg standard equipment



Table size	Legs	Weight			
1000 x 1000 mm	4	301 kg	1.930 £	4-220010.P	•
1200 x 1200 mm	4	395 kg	2.489 £	4-220015.P	•
1500 x 1000 mm	4	420 kg	2.509 £	4-220035.P	•
1500 x 1500 mm	4	585 kg	3.550 £	4-220050.P	•
2000 x 1000 mm	4	529 kg	3.176 £	4-220020.P	•
2400 x 1200 mm	6	740 kg	4.095 £	4-220030.P	•
3000 x 1500 mm	6	1097 kg	5.971 £	4-220040.P	•



Weight = Table Top + Pallet + Leg standard equipment
 Maximum recommended static total load with 4 legs 3000 kg based on even load distribution. (Data only for leg standard equipment)
 All tables are available on order without plasma nitriding or with a diagonal grid: www.siegmund.com/F-table75022



[www.siegmund.com/
F-table75022](http://www.siegmund.com/F-table75022)



Table Legs



	Standard equipment	Standard equipment	Height adjustable	Height adjustable	Caster, locking brake	Height adjustable, caster, locking brake	Floor anchoring
	220858	220857.X	4-220878.XX	4-220877.1.XX	4-220866.XX	4-220879.XX	4-220874.XX
Capacity per table leg	1500 kg	1500 kg	1500 kg	1500 kg	1500 kg	1500 kg	1500 kg
Leg height	700 mm	800 mm	500 – 800 mm	550 – 900 mm	700 mm	600 – 850 mm	700 mm
Fine adjustment	50 mm	50 mm	50 mm	50 mm	20 mm	20 mm	50 mm
Surcharge per leg	included	Alternatively	75 £	76 £	105 £	125 £	58 £

Working height = height of table leg + height of side panel of table
 The specified load capacities refer to static load. Note castor: Not recommended for welding tables with 6 or 8 table legs.

Sets



	220610.1	220630.1	220645.1	220511	220740	220410.N	220420.N	220426.N	220430.N
1	4-223100	4x	2x		12x		4x		
2	4-223200	6x	4x	4x	18x	4x	6x	2x	
3	4-223300	10x	6x	4x	24x	4x	8x	8x	2x
4	4-223400	12x	8x	8x	30x	8x	10x	10x	2x
5	4-223500	14x	10x	8x	30x	8x	12x	12x	4x

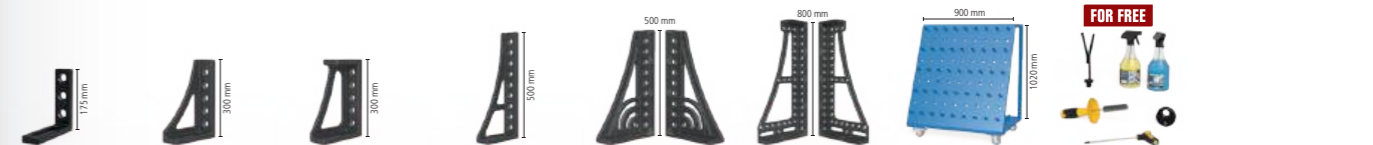

	220110.N	220152.N	220116.N	220162.N	220164+65.N	220144+46.N	220910	223999	
	2x	2x						1x	1.634 £ •
	4x	2x						1x	2.840 £ •
	6x	2x						1x	3.819 £ •
	8x		2x	2x	1x		1x	1x	6.317 £ •
	10x		2x	2x	1x	1x	1x	1x	8.038 £ •

Professional Extreme 8.7

- Through-hardened tool steel X8.7, plasma nitrided and BAR-coated
- Material thickness approx. 17 – 19 mm
- Borehole Ø 22 mm, Boreholes on the surface in diagonal grid
- Height of table side 150 mm, Borehole spacing of table side 50 mm
- Table side panel made of high quality steel S355J2+N
- incl. leg standard equipment



Table size	Legs	Weight			
1000 x 1000 mm	4	295 kg	2.238 £	4-220010.XD7	•
1200 x 800 mm	4	291 kg	2.234 £	4-220025.XD7	•
1200 x 1200 mm	4	387 kg	2.890 £	4-220015.XD7	•
1500 x 1000 mm	4	412 kg	2.917 £	4-220035.XD7	•
1500 x 1500 mm	4	573 kg	4.129 £	4-220050.XD7	•
2000 x 1000 mm	4	519 kg	3.690 £	4-220020.XD7	•
2000 x 1200 mm	4	602 kg	4.314 £	4-220060.XD7	•
2000 x 2000 mm	4	929 kg	6.044 £	4-220045.XD7	•
2400 x 1200 mm	6	725 kg	4.779 £	4-220030.XD7	•
3000 x 1500 mm	6	1073 kg	6.978 £	4-220040.XD7	•
4000 x 2000 mm	8	1807 kg	11.602 £	4-220055.XD7	•

Weight = Table Top + Pallet + Leg standard equipment
 Maximum recommended static total load with 4 legs 3000 kg based on even load distribution. (Data only for leg standard equipment)



www.siegmund.com/
F-tableX722

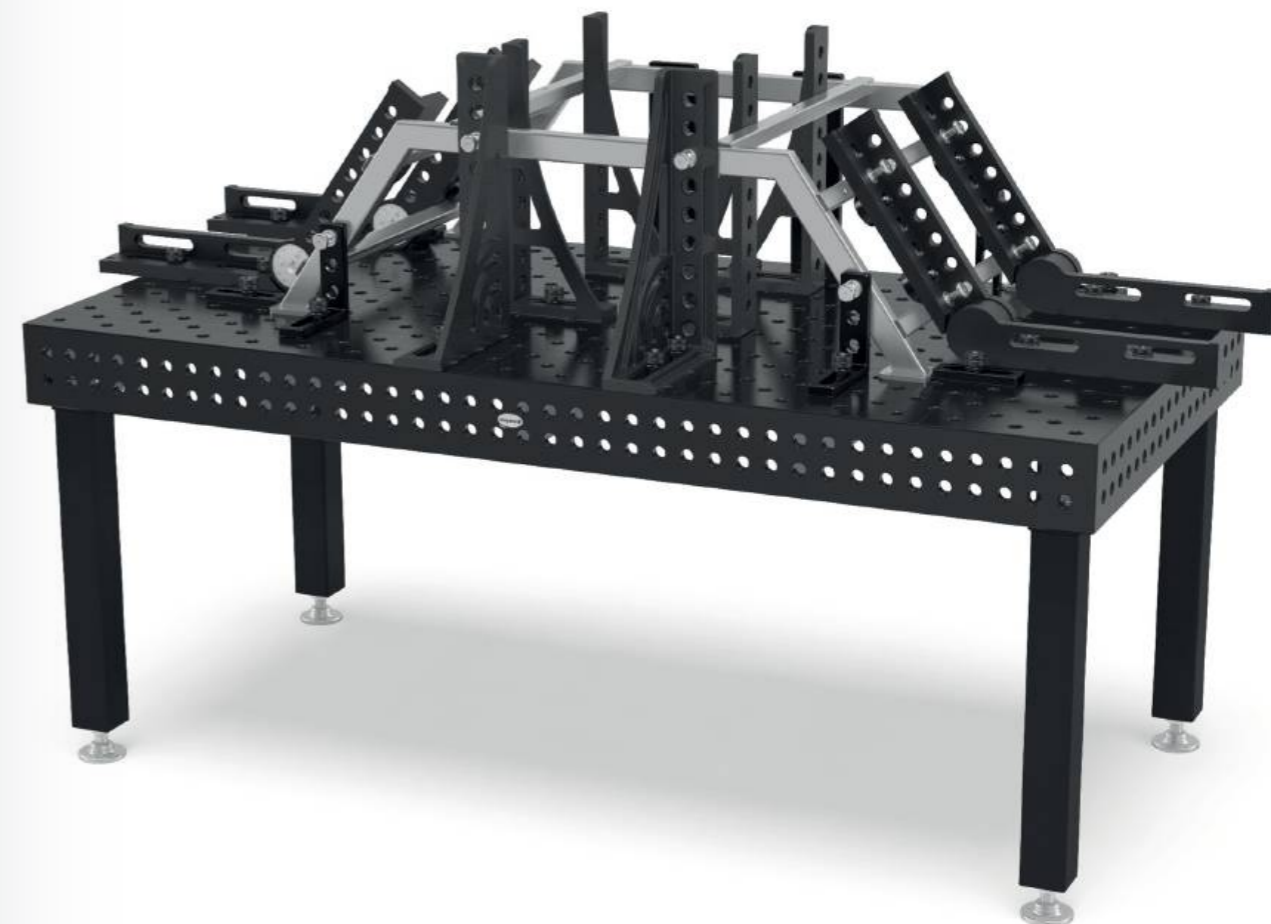

Table Legs



	Standard equipment	Standard equipment	Height adjustable	Height adjustable	Caster, locking brake	Height adjustable, caster, locking brake	Floor anchoring
	220858	220857.X	4-220878.XX	4-220877.1.XX	4-220866.XX	4-220879.XX	4-220874.XX
Capacity per table leg	1500 kg	1500 kg	1500 kg	1500 kg	1500 kg	1500 kg	1500 kg
Leg height	700 mm	800 mm	500 – 800 mm	550 – 900 mm	700 mm	600 – 850 mm	700 mm
Fine adjustment	50 mm	50 mm	50 mm	50 mm	20 mm	20 mm	50 mm
Surcharge per leg	included	Alternatively	75 £	76 £	105 £	125 £	58 £

Working height = height of table leg + height of side panel of table
 The specified load capacities refer to static load. Note castor: Not recommended for welding tables with 6 or 8 table legs.

Sets



	220610.1	220630.1	220645.1	220511	220740	220410.N	220420.N	220426.N	220430.N
1	4-223100	4x	2x		12x		4x		
2	4-223200	6x	4x	4x	18x	4x	6x	2x	
3	4-223300	10x	6x	4x	24x	4x	8x	2x	
4	4-223400	12x	8x	8x	30x	8x	10x	2x	2x
5	4-223500	14x	10x	8x	30x	8x	12x	4x	4x

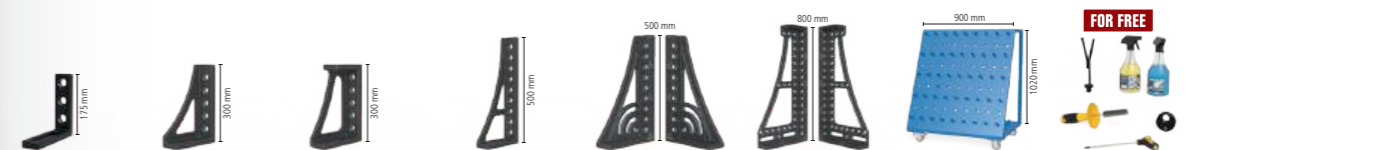
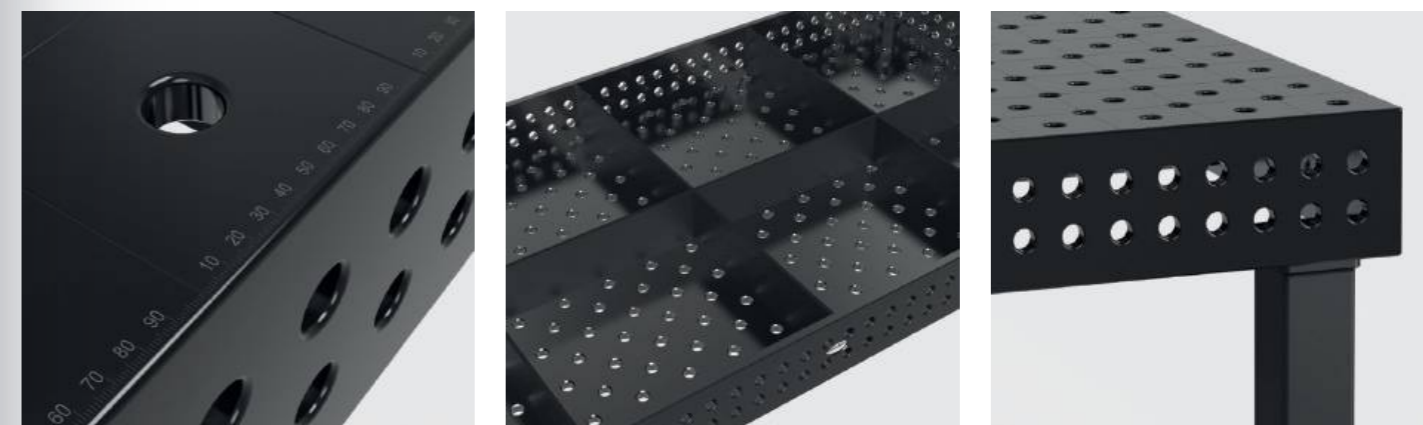

	220110.N	220152.N	220116.N	220162.N	220164+65.N	220144+46.N	220910	223999	
	2x	2x						1x	1.634 £ •
	4x	2x						1x	2.840 £ •
	6x	2x						1x	3.819 £ •
	8x		2x	2x	1x		1x	1x	6.317 £ •
	10x		2x	2x	1x	1x	1x	1x	8.038 £ •

Professional Extreme 8.7 PLUS

- Through-hardened tool steel X8.7, plasma nitrided and BAR-coated
- Material thickness approx. 17 – 19 mm
- Borehole Ø 22 mm, Boreholes on the surface in diagonal grid
- Height of table side 250 mm, Boreholes on table side 4 rows with 50 mm spacing
- Table side panel made of high quality steel S355J2+N
- incl. leg standard equipment



Table size	Legs	Weight			
1200 x 1200 mm	4	459 kg	3.193 £	4-220015.XD7PL	•
1500 x 1000 mm	4	493 kg	3.223 £	4-220035.XD7PL	•
2000 x 1000 mm	4	622 kg	4.079 £	4-220020.XD7PL	•
2400 x 1200 mm	6	849 kg	5.244 £	4-220030.XD7PL	•
3000 x 1500 mm	6	1267 kg	8.033 £	4-220040.XD7PL	•
4000 x 2000 mm	8	2115 kg	12.725 £	4-220055.XD7PL	•

Weight = Table Top + Pallet + Leg standard equipment
 Maximum recommended static total load with 4 legs 3000 kg based on even load distribution. (Data only for leg standard equipment)
 All tables are available on order without plasma nitriding: www.siegmund.com/F-tableX722plus



www.siegmund.com/F-tableX722plus



Table Legs



	Standard equipment	Standard equipment	Height adjustable	Height adjustable	Caster, locking brake	Height adjustable, caster, locking brake	Floor anchoring
	220853.X	220857.X	4-220878.XX	4-220877.1.XX	4-220860.XX	4-220879.XX	4-220872.XX
Capacity per table leg	1500 kg	1500 kg	1500 kg	1500 kg	1500 kg	1500 kg	1500 kg
Leg height	600 mm	800 mm	500 – 800 mm	550 – 900 mm	600 mm	600 – 850 mm	600 mm
Fine adjustment	50 mm	50 mm	50 mm	50 mm	20 mm	20 mm	50 mm
Surcharge per leg	included	Alternatively	75 £	76 £	102 £	125 £	58 £

Working height = height of table leg + height of side panel of table
 The specified load capacities refer to static load. Note castor: Not recommended for welding tables with 6 or 8 table legs.

Sets



	220610.1	220630.1	220645.1	220511	220740	220410.N	220420.N	220426.N	220430.N
1	4-223100	4x	2x		12x		4x		
2	4-223200	6x	4x	4x	18x	4x	6x	2x	
3	4-223300	10x	6x	4x	24x	4x	8x	2x	
4	4-223400	12x	8x	8x	30x	8x	10x	2x	2x
5	4-223500	14x	10x	8x	30x	8x	12x	4x	4x



	220110.N	220152.N	220116.N	220162.N	220164+65.N	220144+46.N	220910	223999	
	2x	2x						1x	1.634 £ •
	4x	2x						1x	2.840 £ •
	6x	2x						1x	3.819 £ •
	8x		2x	2x	1x		1x	1x	6.317 £ •
	10x		2x	2x	1x	1x	1x	1x	8.038 £ •

Siegmund lifting platform

- with two lifting cylinders
- high resilience
- easy handling
- massive scissors and steel rollers
- Contact strip protects against crushing
- Above-floor and underfloor installation possible



Model	L (a)	B (b)	G	Price
Lifting platform 2010 for 2000x1000 mm table, Overall height when retracted: 330 mm, Lifting range: 1100 mm, Lifting time loaded: 45~55 seconds, Force 2,2 kW, Operating voltage 400 V 50 Hz, Maximum load capacity: Basic frame (without a table) 4000 kg, incl. insulation plates	1990 mm	990 mm	470 kg	7.197 £
Lifting platform 2012 for 2000x1200 mm table, Overall height when retracted: 330 mm, Lifting range: 1100 mm, Lifting time loaded: 45~55 seconds, Force 2,2 kW, Operating voltage 400 V 50 Hz, Maximum load capacity: Basic frame (without a table) 4000 kg, incl. insulation plates	1990 mm	1190 mm	490 kg	7.461 £
Lifting platform 2412 for 2400x1200 mm table, Overall height when retracted: 330 mm, Lifting range: 1100 mm, Lifting time loaded: 45~55 seconds, Force 2,2 kW, Operating voltage 400 V 50 Hz, Maximum load capacity: Basic frame (without a table) 4000 kg, incl. insulation plates	2390 mm	1190 mm	530 kg	7.974 £
Lifting platform 3015 for 3000x1500 mm table, Overall height when retracted: 430 mm, Lifting range: 650 mm, Lifting time loaded: 35~45 seconds, Force 2,2 kW, Operating voltage 400 V 50 Hz, Maximum load capacity: Basic frame (without a table) 6000 kg, incl. insulation plates	2990 mm	1490 mm	865 kg	12.330 £

Lifting platform 2010 with welding table

- incl. welding table 2000x1000 mm and insulation plates
- Material thickness Table Top approx. 17 – 19 mm
- Dimensions (L x W): approx. 1990x990 mm
- Weight (without a table) approx. 470 kg
- Overall height when retracted: 330 mm, Lifting range: 1100 mm
- Working height is overall height plus table side panel
- Maximum load capacity: Basic frame (without a table) 4000 kg
- Lifting time loaded: 45~55 seconds
- Force 2,2 kW, Operating voltage 400 V 50 Hz



Size Working surface	Specifications Working surface	G	Price
2000 x 1000 mm	22 750 N BAR	969 kg	10.097 £ 4-HB220020.P
2000 x 1000 mm	22 XB.7 N BAR	959 kg	10.612 £ 4-HB220020.XD7
2000 x 1000 mm	22 XB.7 N BAR	1065 kg	11.000 £ 4-HB220020.XD7PL

Lifting platform 2012 with welding table

- incl. welding table 2000x1200 mm and insulation plates
- Material thickness Table Top approx. 17 – 19 mm
- Dimensions (L x W): approx. 1990x1190 mm
- Weight (without a table) approx. 490 kg
- Overall height when retracted: 330 mm, Lifting range: 1100 mm
- Working height is overall height plus table side panel
- Maximum load capacity: Basic frame (without a table) 4000 kg
- Lifting time loaded: 45~55 seconds
- Force 2,2 kW, Operating voltage 400 V 50 Hz



Size Working surface	Specifications Working surface	G	Price
2000 x 1200 mm	22 XB.7 N BAR	1062 kg	11.499 £ 4-HB220060.XD7

Lifting platform 2412 with welding table

- incl. welding table 2400x1200 mm and insulation plates
- Material thickness Table Top approx. 17 – 19 mm
- Dimensions (L x W): approx. 2390x1190 mm
- Weight (without a table) approx. 530 kg
- Overall height when retracted: 330 mm, Lifting range: 1100 mm
- Working height is overall height plus table side panel
- Maximum load capacity: Basic frame (without a table) 4000 kg
- Lifting time loaded: 45~55 seconds
- Force 2,2 kW, Operating voltage 400 V 50 Hz



Size Working surface	Specifications Working surface	G	Price
2400 x 1200 mm	22 750 N BAR	1225 kg	11.655 £ 4-HB220030.P
2400 x 1200 mm	22 XB.7 N BAR	1210 kg	12.339 £ 4-HB220030.XD7
2400 x 1200 mm	22 XB.7 N BAR	1338 kg	12.804 £ 4-HB220030.XD7PL

Lifting platform 3015 with welding table

- incl. welding table 3000x1500 mm and insulation plates
- Material thickness Table Top approx. 17 – 19 mm
- Dimensions (L x W): approx. 2990x1490 mm
- Weight (without a table) approx. 865 kg
- Overall height when retracted: 430 mm, Lifting range: 650 mm
- Working height is overall height plus table side panel
- Maximum load capacity: Basic frame (without a table) 6000 kg
- Lifting time loaded: 34~45 seconds
- Force 2,2 kW, Operating voltage 400 V 50 Hz



Size Working surface	Specifications Working surface	G	Price
3000 x 1500 mm	22 750 N BAR	1917 kg	17.887 £ 4-HB220040.P
3000 x 1500 mm	22 XB.7 N BAR	1893 kg	18.894 £ 4-HB220040.XD7
3000 x 1500 mm	22 XB.7 N BAR	2091 kg	19.949 £ 4-HB220040.XD7PL



You can find more information and accessories for these products online.



www.siegmund.com/
F-h-lift

Rotating table height adjustable static

- Dimensions (L x W): approx. 785x785 mm
- Weight (without plate): approx. 70 kg
- Working height between 780 mm and 1100 mm
- Due to the danger of tipping, we exclusively recommend the sizes shown
- Only compatible with specified worktops (special attachment points in the worktop)
- Maximum load capacity: Basic frame (without plate) 1000 kg



Size Working surface	Specifications Working surface	MS (d)	G			
1000 x 1000 mm	22 750 N BAR	18 mm	207 kg	2.074 £	2-DS224024.PD	•
1200 x 1200 mm	22 750 N BAR	18 mm	267 kg	2.440 £	2-DS224034.PD	•
1200 x 800 mm	22 750 N BAR	18 mm	208 kg	1.947 £	2-DS224004.P	•
Ø 1100 mm	22 750 N BAR	18 mm	201 kg	2.331 £	2-DS224211.PD	•

Rotating table height adjustable portable

- Dimensions (L x W): approx. 795x795 mm
- Weight (without plate): approx. 70 kg
- Working height between 780 mm and 1100 mm
- Due to the danger of tipping, we exclusively recommend the sizes shown
- Only compatible with specified worktops (special attachment points in the worktop)
- Maximum load capacity: Basic frame (without plate) 1000 kg



Size Working surface	Specifications Working surface	MS (d)	G			
1000 x 1000 mm	22 750 N BAR	18 mm	207 kg	2.215 £	2-DM224024.PD	•
1200 x 1200 mm	22 750 N BAR	18 mm	267 kg	2.582 £	2-DM224034.PD	•
1200 x 800 mm	22 750 N BAR	18 mm	208 kg	2.089 £	2-DM224004.P	•
Ø 1100 mm	22 750 N BAR	18 mm	201 kg	2.473 £	2-DM224211.PD	•

Magnetic ground connection

Magnetic ground connection with rotary joint for a high holding force on clean and smooth surfaces. No more twisting cables thanks to the quick and easy grounding. Connection can be clamped or hard-wired. In combination with an adapter plate and countersunk-head screw, it is perfectly suited as a retrofit set for the rotating table.



Magnetic ground connection for rotating table

quick and easy grounding, no cable twisting, high holding force on clean and smooth surfaces, Delivery contents: Adapter plate and countersunk-head screw

16 22 28

2-00003399

G 0,92 kg

40 £ •

Mobile lifting table 500 kg

- Dimensions (L x W): approx. 1115x630 mm
- Weight (without plate): approx. 65 kg
- Working height from approx. 700 to 1000 mm
- Only compatible with specified worktops (special attachment points in the worktop)
- Maximum load capacity: Basic frame (without plate) 500 kg



Size Working surface	Specifications Working surface	MS (d)	G			
1200 x 800 mm	22 750 N BAR	18 mm	203 kg	2.385 £	2-HT224004.P	•

Mobile lifting table 1200 kg

- Dimensions (L x W): approx. 1490x990 mm
- Weight (without plate): approx. 210 kg
- Working height from approx. 750 to 1050 mm
- Maximum load capacity: Basic frame (without plate) 1200 kg



Size Working surface	Specifications Working surface	MS (d)	G			
1500 x 1000 mm	22 750 N BAR	18 mm	548 kg	5.103 £	2-HS220035.P	•

Product recommendation



Supplementary set, load-bearing capacity 1700 kg

Second lifting cylinder for 1700 kg load-bearing capacity (minus plate), Only compatible with mobile lifting table 1200 kg, Scope of delivery: 1x lifting cylinder, 1x foot pedal, fastening material

16 22 28

2-HS009921

G

4 kg

474 £ •



You can find more information and accessories for these products online.



www.siegmund.com/
F-rotating



You can find more information and accessories for these products online.



www.siegmund.com/
F-lifting

Siegmund Workstation 1208

- left and right 600 mm space for drawers
- incl. Perforated plate 1200x800 mm
- premium steel S355J2+N, plasma nitrided and BAR-coated
- Material thickness approx. 18 mm
- Borehole Ø 22 mm
- Boreholes on the surface 100x100 mm grid
- Maximum load capacity: base plate 1000 kg (without plate) / Castor 400 kg (without plate)



Siegmund Workstation 1208

Delivery contents: 1x 004002.1 Siegmund Workstation 1208 Basic frame, 1x 224004.P Perforated plate



	L (a)	B (b)	H (c)	G	Special offer price
2-224400	1200 mm	800 mm	850 mm	170 kg	1.400 £ • instead of 1.423 £

Siegmund Workstation 1208 incl. Shelves

Delivery contents: 1x 004002.1 Siegmund Workstation 1208 Basic frame, 1x 224004.P Perforated plate, 1x 224030 Clamp holder, 1x 004620 Shelf, 1x 224635 Bolt and prism holder, 1x 004025.1 Toolwall incl. Shelf



	L (a)	B (b)	H (c)	G	Special offer price
2-224401	1200 mm	800 mm	850 mm	179,79 kg	1.536 £ • instead of 1.566 £

Siegmund Workstation 1208 half closed incl. 3 drawers

Delivery contents: 1x 004002.1 Siegmund Workstation 1208 Basic frame, 1x 224004.P Perforated plate, 2x 004230 Drawer 180 mm, 1x 004235 Drawer 240 mm, 1x 004120 Set side walls



	L (a)	B (b)	H (c)	G	Special offer price
2-224407	1200 mm	800 mm	850 mm	202,50 kg	1.830 £ • instead of 1.858 £

Siegmund Workstation 1208 closed incl. 6 drawers

Delivery contents: 1x 004002.1 Siegmund Workstation 1208 Basic frame, 1x 224004.P Perforated plate, 4x 004230 Drawer 180 mm, 2x 004235 Drawer 240 mm, 2x 004120 Set side walls



	L (a)	B (b)	H (c)	G	Special offer price
2-224409	1200 mm	800 mm	850 mm	235 kg	2.261 £ • instead of 2.294 £

plus packaging / Shipping

Siegmund Workstation 1208 – Configuration

Equipment with 4 castors for Workstation 1208

switch between feet and castors possible



	TF	G	Special offer price
2-004100.1	400 kg	5,30 kg	78 £ •

Drawer with clip rail and mounting for Workstation 0806 / 1208

powder coated finish, upgrading possible at any time, for Workstation 0806 / 1208 without side walls, mounting is required if there are no side walls in the Workstation



	L (a)	B (b)	H (c)	TF	G	Special offer price
2-004220.WS	590 mm	400 mm	60 mm	50 kg	7,50 kg	87 £ •
2-004225.WS	590 mm	400 mm	120 mm	50 kg	9 kg	98 £ •
2-004230.WS	590 mm	400 mm	180 mm	50 kg	9,50 kg	109 £ •
2-004235.WS	590 mm	400 mm	240 mm	50 kg	10 kg	120 £ •

You can find more information and accessories for these products online. www.siegmund.com/F-workstation

Siegmund Workstation 1212

- left and right 600 mm space for drawers
- incl. Perforated plate 1200x1200 mm
- premium steel S355J2+N, plasma nitrided and BAR-coated
- Material thickness approx. 18 mm
- Borehole Ø 22 mm
- Boreholes on the surface 100x100 mm grid
- Maximum load capacity: base plate 1000 kg (without plate) / Castor 400 kg (without plate)



Siegmund Workstation 1212

Delivery contents: 1x 004602 Siegmund Workstation 1212 Basic frame, 1x 224034.P Perforated plate



	L (a)	B (b)	H (c)	G	Special offer price
2-224600	1200 mm	1200 mm	850 mm	247,80 kg	1.742 £ • instead of 1.762 £

Siegmund Workstation 1212 incl. Shelves

Delivery contents: 1x 004602 Siegmund Workstation 1212 Basic frame, 1x 224034.P Perforated plate, 1x 224630 Clamp holder, 1x 004620 Shelf, 1x 224635 Bolt and prism holder, 1x 004625 Toolwall incl. Shelf



	L (a)	B (b)	H (c)	G	Special offer price
2-224601	1200 mm	1200 mm	850 mm	260,55 kg	1.887 £ • instead of 1.916 £

Siegmund Workstation 1212 half closed incl. 3 drawers

Delivery contents: 1x 004602 Siegmund Workstation 1212 Basic frame, 1x 224034.P Perforated plate, 2x 004230 Drawer 180 mm, 1x 004235 Drawer 240 mm, 1x 004720 Set side walls



	L (a)	B (b)	H (c)	G	Special offer price
2-224607	1200 mm	1200 mm	850 mm	281,80 kg	2.179 £ • instead of 2.206 £

Siegmund Workstation 1212 closed incl. 6 drawers

Delivery contents: 1x 004602 Siegmund Workstation 1212 Basic frame, 1x 224034.P Perforated plate, 4x 004230 Drawer 180 mm, 2x 004235 Drawer 240 mm, 2x 004720 Set side walls



	L (a)	B (b)	H (c)	G	Special offer price
2-224609	1200 mm	1200 mm	850 mm	315,80 kg	2.617 £ • instead of 2.649 £

plus packaging / Shipping

Siegmund Workstation 1212 – Configuration

Equipment with 4 castors for Workstation 1212

switch between feet and castors possible



	TF	G	Special offer price
2-004700	400 kg	4,30 kg	86 £ •

Drawer with clip rail and mounting for Workstation 1212

powder coated finish, upgrading possible at any time, for Workstation 1212 without side walls, mounting is required if there are no side walls in the Workstation

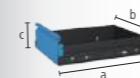

	L (a)	B (b)	H (c)	TF	G	Special offer price
2-004820.WS	590 mm	400 mm	60 mm	50 kg	8 kg	92 £ •
2-004825.WS	590 mm	400 mm	120 mm	50 kg	9,50 kg	103 £ •
2-004830.WS	590 mm	400 mm	180 mm	50 kg	10 kg	114 £ •
2-004835.WS	590 mm	400 mm	240 mm	50 kg	10,50 kg	125 £ •

You can find more information and accessories for these products online. www.siegmund.com/F-workstation

Octagonal Table 150

fixation via adapter plate (not included in the scope of delivery), Adapter plate available on request at an additional cost, Discount: starting at 2 pieces: 5%, starting at 5 pieces: 10%



	L (a)	B (b)	H (c)	MS (d)	Ø	G	
2-920822.P	331 mm	800 mm	150 mm	18 mm	866 mm	210 kg	5.174 £ ○
2-921022.P	414 mm	1000 mm	150 mm	18 mm	1082 mm	276 kg	5.936 £ ○
2-921222.P	497 mm	1200 mm	150 mm	18 mm	1299 mm	368 kg	8.828 £ ○
2-921422.P	580 mm	1400 mm	150 mm	18 mm	1515 mm	477 kg	9.589 £ ○
2-921522.P	621 mm	1500 mm	150 mm	18 mm	1624 mm	525 kg	10.349 £ ○
2-921622.P	663 mm	1600 mm	150 mm	18 mm	1732 mm	604 kg	11.110 £ ○
2-921722.P	704 mm	1700 mm	150 mm	18 mm	1840 mm	655 kg	12.056 £ ○
2-921822.P	746 mm	1800 mm	150 mm	18 mm	1948 mm	710 kg	11.871 £ ○

Octagonal Plate

fixation through bore holes using support sleeves (220500), M8 thread on the side, Discount: starting at 2 pieces: 5%, starting at 5 pieces: 10%

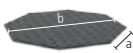

	L (a)	B (b)	H (c)	MS (d)	Ø	G	
2-930600.P	249 mm	600 mm	18 mm	18 mm	650 mm	79 kg	2.434 £ ○
2-930800.P	331 mm	800 mm	18 mm	18 mm	866 mm	112 kg	3.043 £ ○
2-931000.P	414 mm	1000 mm	18 mm	18 mm	1083 mm	155 kg	3.652 £ ○
2-931200.P	497 mm	1200 mm	18 mm	18 mm	1299 mm	220 kg	4.604 £ ○
2-931400.P	580 mm	1400 mm	18 mm	18 mm	1516 mm	305 kg	5.792 £ ○
2-931500.P	621 mm	1500 mm	18 mm	18 mm	1636 mm	339 kg	6.139 £ ○

Weight = Octagonal Plate + Pallet
 Due to customer specific adaptation the weight can vary.
 Further table sizes are available on request.
 Foot plates or adapter plates are not included as standard in the octagonal tables.

Adapter plate available on request at an additional cost

To connect the Octagonal Table with a positioner, an adapter plate is required. Upon request, the adapter plate with special connecting hole pattern can be custom-made against a surcharge.

Surcharge for customizing Adapter Plate

for octagonal tables with side panels



0-940000	719 £ ○
----------	----------------

Surcharge for customization of the drill circle

for octagonal plates



0-940000.1	535 £ ○
------------	----------------

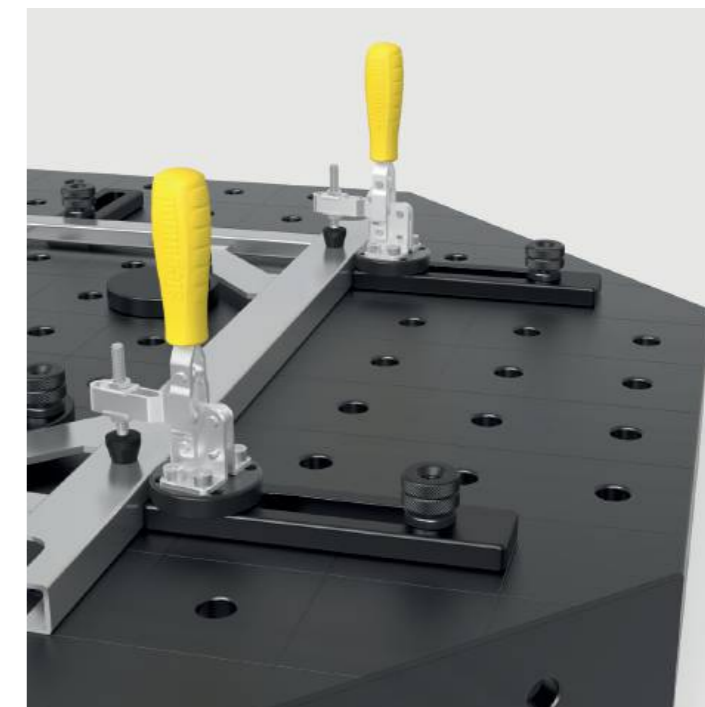
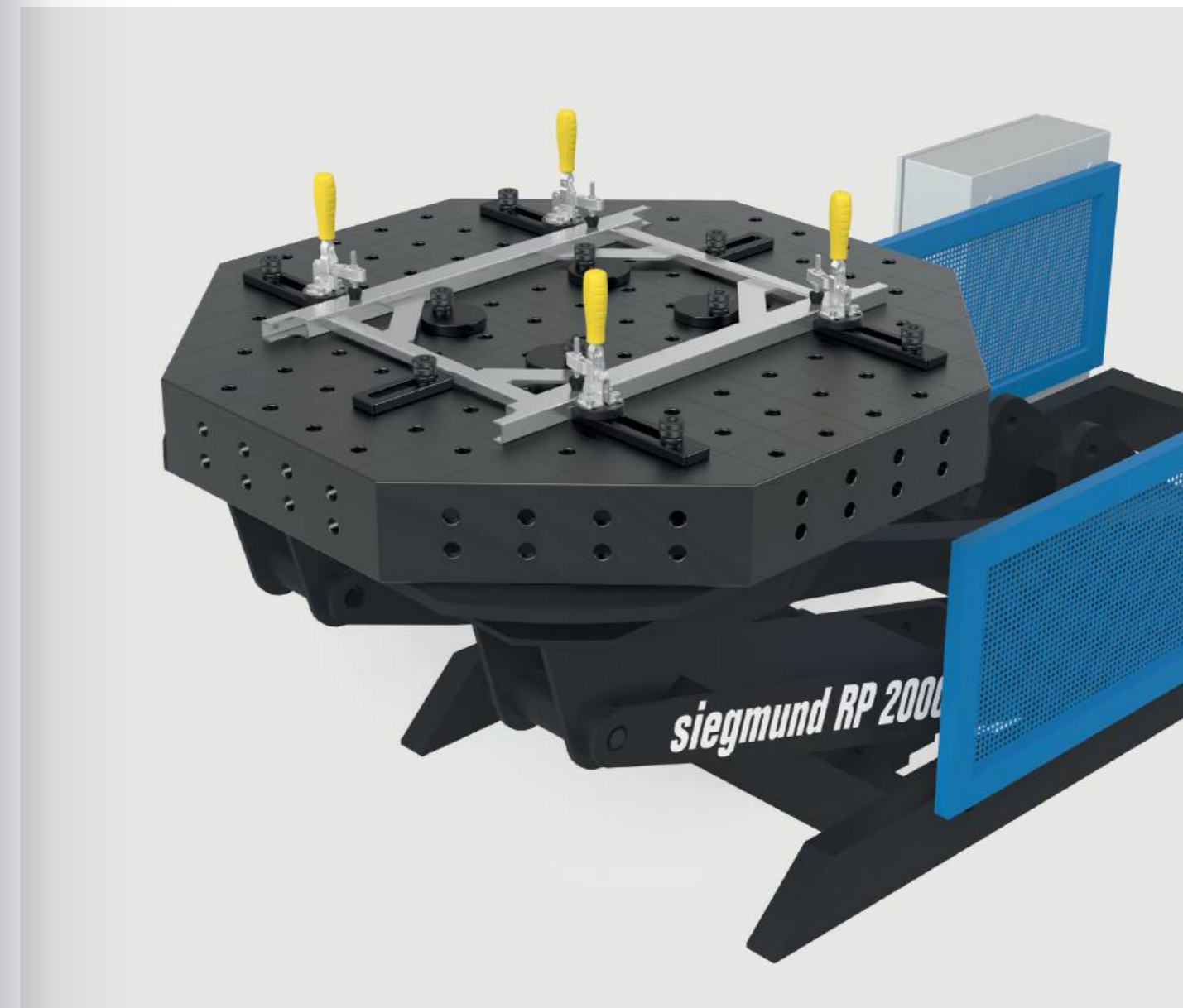

You can find more information and accessories for these products online.



www.siegmund.com/
F-octagonal22

Eccentric Stop Ø 60 with M10 thread nitrided
for ground connection, stepless adjusting



	MS (d)	Ø	G	
2-220402.N	18 mm	60 mm	0,33 kg	24 £ •

Eccentric Stop Ø 100 nitrided
also serves as a support surface, stepless adjusting



	MS (d)	Ø	G	
2-220403.N	18 mm	100 mm	1,04 kg	25 £ •



You can find more information and accessories for these products online.



www.siegmund.com/
F-stop22



Universal Stop 150 L nitrided
elongated hole



	L (a)	B (b)	VB (f)	MS (d)	G	
2-220410.N	150 mm	50 mm	100 mm	18 mm	0,67 kg	34 £ •

Universal Stop 225 L nitrided
combination of borehole and elongated hole, for use with both prisms and adapters



	L (a)	B (b)	VB (f)	MS (d)	G	
2-220420.N	225 mm	50 mm	100 mm	18 mm	1,14 kg	53 £ •

Universal Stop 300 nitrided
combination of borehole and elongated hole



	L (a)	B (b)	VB (f)	MS (d)	G	
2-220426.N	300 mm	50 mm	100 mm	18 mm	1,54 kg	59 £ •

Universal Stop 500 S nitrided
combination of borehole and elongated hole



	L (a)	B (b)	VB (f)	MS (d)	G	
2-220430.N	500 mm	100 mm	200 mm	18 mm	6,01 kg	85 £ •

Stop and Clamping Square 175 L nitrided

combination of borehole and elongated hole

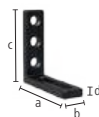

	L (a)	B (b)	H (c)	MS (d)	G	
2-220110.N	175 mm	50 mm	175 mm	18 mm	1,65 kg	79 £ •

Stop and Clamping Square 175 VL nitrided

with boreholes, no elongated hole

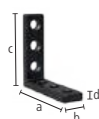

	L (a)	B (b)	H (c)	MS (d)	G	
2-220113.N	175 mm	50 mm	175 mm	18 mm	1,96 kg	70 £ •

Stop and Clamping Square 175 WL nitrided

elongated hole, flexible in any direction



	L (a)	B (b)	H (c)	MS (d)	G	
2-220111.N	175 mm	50 mm	175 mm	18 mm	1,57 kg	79 £ •

Stop and Clamping Square 300 G / 500 G nitrided

usable as table extension, material: GGG40

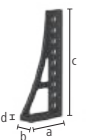

	L (a)	B (b)	H (c)	MS (d)	G	
2-220152.N left	200 mm	75 mm	300 mm	20 mm	5,70 kg	110 £ •
2-220162.N left	193 mm	75 mm	500 mm	20 mm	7,80 kg	144 £ •

Stop and Clamping Square 300x195 nitrided



	L (a)	B (b)	H (c)	MS (d)	G	
2-220116.N	195 mm	75 mm	300 mm	20 mm	6,74 kg	94 £ •



Stop and Clamping Square 300 GK nitrided

usable as table extension, for heavy components, material: GGG40, recommended as a pair



	L (a)	B (b)	H (c)	MS (d)	G	
2-220124.N left	280 mm	95 mm	300 mm	20 mm	11,50 kg	195 £ •
2-220126.N right	280 mm	95 mm	300 mm	20 mm	11,50 kg	195 £ •

Stop and Clamping Square 500 G with rotation angle nitrided

usable as table extension, material: GGG40, recommended as a pair



	L (a)	B (b)	H (c)	MS (d)	G	
2-220164.N left	276 mm	95 mm	500 mm	20 mm	11,60 kg	210 £ •
2-220165.N right	276 mm	95 mm	500 mm	20 mm	11,60 kg	210 £ •

Stop and Clamping Square 600 GK / 800 GK nitrided

usable as table extension, for heavy components, material: GGG40, recommended as a pair

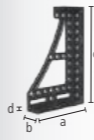

	L (a)	B (b)	H (c)	MS (d)	G	
2-220134.N left	373 mm	95 mm	600 mm	20 mm	21,80 kg	301 £ •
2-220136.N right	373 mm	95 mm	600 mm	20 mm	21,80 kg	301 £ •
2-220144.N left	373 mm	95 mm	800 mm	20 mm	25,80 kg	429 £ •
2-220146.N right	373 mm	95 mm	800 mm	20 mm	25,80 kg	429 £ •

Corner Connection small, Cast Iron nitrided

45° diagonal table extension, material: GGG40



	L (a)	B (b)	H (c)	G	
2-220190.N	200 mm	150 mm	115 mm	10 kg	251 £ •

Universal Angle Hydromechanical Clamping burnished

225° infinite adjustment, suitable matching hex wrench 14 (280854) not included



	SL (e)	G	
2-220171	475 mm	23 kg	614 £ •

Square U-Shape 200x150 Plasma nitrided

to connect tables (with connecting bolt 220563), as table extension and vertical superstructure, from 500 mm with mounting holes for table legs, from 1000 mm support through table leg required



	L (a)	B (b)	H (c)	MS (d)	G	
2-220350.P	200 mm	200 mm	150 mm	18 mm	19 kg	391 £ •
2-220360.P	500 mm	200 mm	150 mm	18 mm	43 kg	520 £ •
2-220370.P	1000 mm	200 mm	150 mm	18 mm	75 kg	851 £ •
2-220380.P	1500 mm	200 mm	150 mm	18 mm	107 kg	1.145 £ •
2-220390.P	2000 mm	200 mm	150 mm	18 mm	141 kg	1.470 £ •



You can find more information and accessories for these products online.



www.siegmund.com/
F-square22

Aluminum profile square

- Quickly ready for use thanks to clamping plates on the front ends
- Flexible mounting options thanks to integrated hexagonal slot
- Lightweight design for easy handling
- Ideal as a table extension or additional vertical clamping surface
- Cost-optimized through integrated components

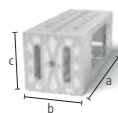

Aluminum profile square 500x200x200 with hexagonal slot

Clamping plate on both ends, with hexagonal slot HX14, as table extension and vertical clamping surface, from 1000 mm support through table leg required (2x Reduction Bushing 000542 required), Flatness tolerance < 0,9 mm / 1000 mm

NEW



	L (a)	B (b)	H (c)	G	
4-AQ22HX500	500 mm	200 mm	200 mm	9,30 kg	241 £ •
4-AQ22HX800	800 mm	200 mm	200 mm	13,30 kg	341 £ •
4-AQ22HX1000	1000 mm	200 mm	200 mm	16,30 kg	408 £ •
4-AQ22HX1200	1200 mm	200 mm	200 mm	18,60 kg	475 £ •
4-AQ22HX1500	1500 mm	200 mm	200 mm	21 kg	575 £ •
4-AQ22HX2000	2000 mm	200 mm	200 mm	29,90 kg	744 £ •

Sliding Blocks

Sliding Block HX14 Standard nitrided

with M12 thread, attachment of accessories with M12 screw, place it into the desired position by inserting it into the slot from the side



	L (a)	B (b)	H (c)	G	
2-HN280547	25 mm	30 mm	14 mm	0,06 kg	8 £ •

Sliding Block HX14 rotatable nitrided

attachment of accessories with M12 screw, enables placement in the slot from above, tensions in the slot when turning in the direction of fastening the screw



	L (a)	B (b)	H (c)	G	
2-HN280547.1	40 mm	30 mm	14 mm	0,04 kg	10 £ •

Sliding Block HX14 long nitrided

with M12 thread



	L (a)	B (b)	H (c)	G	
2-HN280547.2	40 mm	30 mm	14 mm	0,08 kg	10 £ •



You can find more information and accessories for these products online.



www.siegmund.com/
F-profile

Aluminum profile bracket

Aluminum profile bracket 200x36 mm (50 mm Grid)

Version with full grid with many clamping options, Requires Clamping Bolt without slot Triple, as table extension and vertical clamping surface, from 1000 mm support through table leg required (2x Reduction Bushing 000542 required)

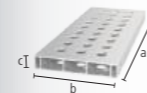

	L (a)	B (b)	H (c)	G	
4-AR22014050.V	500 mm	200 mm	36 mm	2,57 kg	47 £ •
4-AR22014080.V	800 mm	200 mm	36 mm	4,09 kg	70 £ •
4-AR22014100.V	1000 mm	200 mm	36 mm	5,30 kg	84 £ •
4-AR22014120.V	1200 mm	200 mm	36 mm	6,11 kg	101 £ •
4-AR22014150.V	1500 mm	200 mm	36 mm	7,62 kg	134 £ •
4-AR22014200.V	2000 mm	200 mm	36 mm	10,14 kg	167 £ •

Aluminum profile bracket 200x36 mm (50 mm Grid with elongated hole)

Variable clamping also possible at an angle, Requires Clamping Bolt without slot Triple, as table extension and vertical clamping surface, from 1000 mm support through table leg required (2x Reduction Bushing 000542 required)

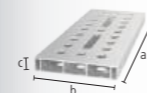

	L (a)	B (b)	H (c)	G	
4-AR22014050.VL	500 mm	200 mm	36 mm	2,53 kg	53 £ •
4-AR22014080.VL	800 mm	200 mm	36 mm	4 kg	81 £ •
4-AR22014100.VL	1000 mm	200 mm	36 mm	4,99 kg	95 £ •
4-AR22014120.VL	1200 mm	200 mm	36 mm	5,97 kg	117 £ •
4-AR22014150.VL	1500 mm	200 mm	36 mm	7,47 kg	152 £ •
4-AR22014200.VL	2000 mm	200 mm	36 mm	9,93 kg	190 £ •

Accessories

Adapter for screw clamps nitrided

for using screw clamps in aluminum profiles, for Screw Clamps: 220610.1, 220630.1, 220615



	L (a)	ø	G	
2-AP220605.N basic	63 mm	35 mm	0,27 kg	14 £ •
2-AP220602.N double	81 mm	35 mm	0,32 kg	17 £ •

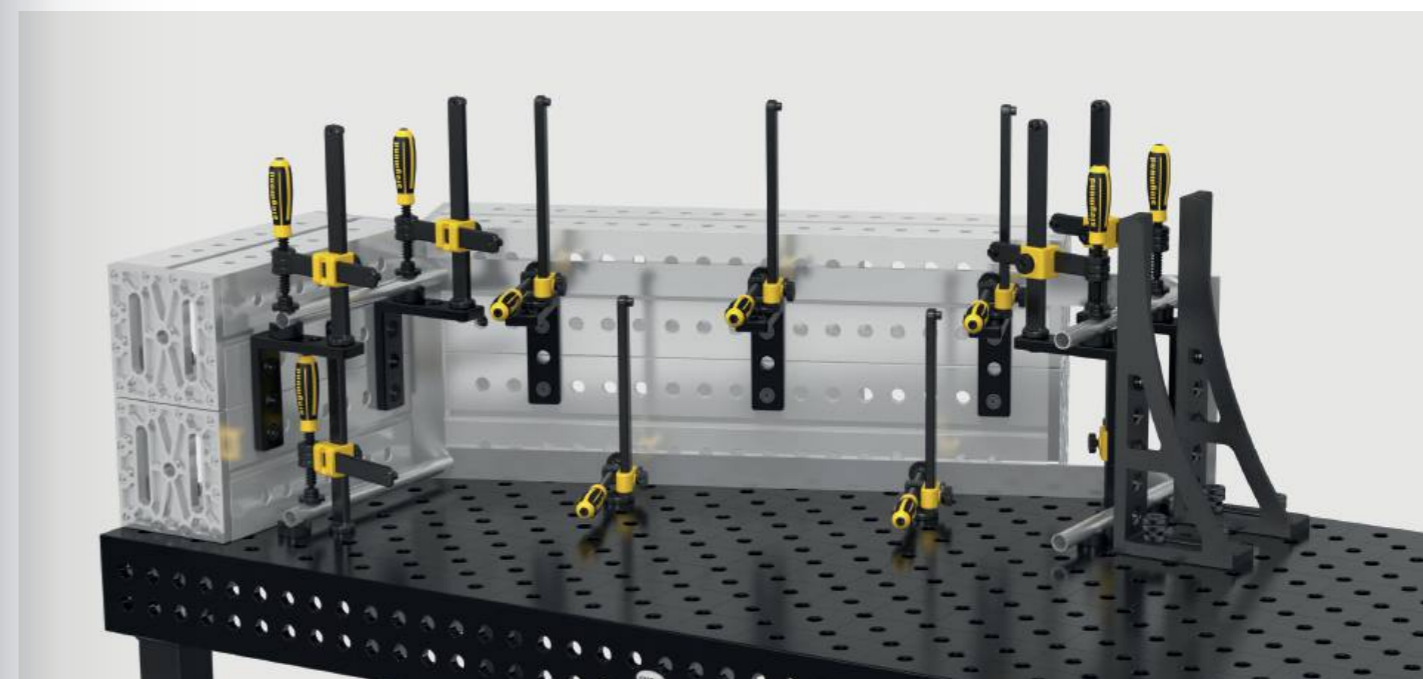

**Areal Clamping Bolt burnished**

220590: Clamping range approx. 33-39 mm, 220590.3: Clamping range approx. 51-57 mm, 220590.4: Clamping range approx. 69-75 mm, recommended for clamping aluminum profiles, MUST NOT be used for connecting tables and U-shaped squares

B 22

		L (a)	SK	ZK1	ZK	AM1	AM	G	
2-220590	double	84 mm	150 kN	3 kN	10 kN	15 Nm	25 Nm	0,33 kg	53 £ •
2-220590.3	triple	102 mm	150 kN	3 kN	10 kN	15 Nm	25 Nm	0,38 kg	58 £ •
2-220590.4	quadruple	120 mm	150 kN	3 kN	10 kN	15 Nm	25 Nm	0,43 kg	64 £ •

**Areal Clamping Flush Mount Bolt burnished**

countersunk connection of components, 220595: Clamping range approx. 33-39 mm, 220595.3: Clamping range approx. 51-57 mm, 220595.4: Clamping range approx. 69-75 mm, not suitable for elongated holes, MUST NOT be used for connecting tables and U-shaped squares

B 22

		L (a)	SK	ZK1	ZK	AM1	AM	G	
2-220595	double	49 mm	130 kN	3 kN	6 kN	15 Nm	25 Nm	0,12 kg	43 £ •
2-220595.3	triple	67 mm	130 kN	3 kN	6 kN	15 Nm	25 Nm	0,18 kg	48 £ •
2-220595.4	quadruple	85 mm	130 kN	3 kN	6 kN	15 Nm	25 Nm	0,23 kg	53 £ •

**Fast Clamping Bolt without slot burnished**

without O-ring slot for a smooth surface, MUST NOT be used for connecting tables and U-shaped squares

B 22

		L (a)	SK	ZK	AM1	AM	G	
2-220511	double	83 mm	130 kN	15 kN	6 Nm	15 Nm	0,27 kg	44 £ •
2-220513	triple	101 mm	130 kN	15 kN	6 Nm	15 Nm	0,32 kg	56 £ •
2-220515	quadruple	119 mm	130 kN	15 kN	6 Nm	15 Nm	0,37 kg	67 £ •

**Flush Mount Bolt without slot burnished**

countersunk connection of components, only for clamping aluminum profiles, tighten aluminum parts only hand-tight

B 22

		L (a)	SK	ZK	AM1	AM	G	
2-AP220528	double	50 mm	130 kN	2 kN	6 Nm	0,13 kg		34 £ •
2-AP220529	triple	68 mm	130 kN	2 kN	6 Nm	0,18 kg		41 £ •
2-AP220530	quadruple	86 mm	130 kN	2 kN	6 Nm	0,23 kg		47 £ •

**Flush Mount Bolt burnished**

countersunk connection of components, MUST NOT be used for connecting tables and U-shaped squares, not suitable for aluminum profiles, not suitable for elongated holes

B 22

		L (a)	SK	ZK	AM	G	
2-220528	double	49 mm	130 kN	6 kN	15 Nm	0,12 kg	41 £ •
2-220529	triple	67 mm	130 kN	6 kN	15 Nm	0,16 kg	47 £ •

**Connecting Bolt with collar burnished**

to connect tables, U-squares and aluminum profiles, suitable for elongated holes, fixed long-term connection

B 22

		L (a)	SK	ZK	AM1	AM	G	
2-220583	double	55 mm	130 kN	15 kN	30 Nm	35 Nm	0,20 kg	23 £ •
2-220584	triple	73 mm	130 kN	15 kN	30 Nm	35 Nm	0,27 kg	29 £ •
2-220585	quadruple	91 mm	130 kN	15 kN	30 Nm	35 Nm	0,30 kg	35 £ •

**Fast Clamping Bolt flat without slot burnished**

minimal protrusion, MUST NOT be used for connecting tables and U-shaped squares, suitable for aluminum profiles, suitable for elongated holes

B 22

		L (a)	SK	ZK	AM1	AM	G	
2-220524	double	57 mm	130 kN	15 kN	6 Nm	15 Nm	0,16 kg	41 £ •
2-220525	triple	75 mm	130 kN	15 kN	6 Nm	15 Nm	0,20 kg	47 £ •

**Fast Clamping Bolt adjustable without slot burnished**

220571: Clamping range approx. 18-36 mm, 220573: Clamping range approx. 36-54 mm, clamping of customized laser cut profiles, suitable for aluminum profiles, tighten aluminum parts only hand-tight, MUST NOT be used for connecting tables and U-shaped squares

B 22

		L (a)	SK	ZK	AM1	AM	G	
2-220571	double	95 mm	130 kN	15 kN	6 Nm	15 Nm	0,40 kg	51 £ •
2-220573	triple	113 mm	130 kN	15 kN	6 Nm	15 Nm	0,46 kg	61 £ •

**Universal Bolt Comfort burnished**

220532: Clamping range approx. 33-39 mm, 220533: Clamping range approx. 51-57 mm, MUST NOT be used for connecting tables and U-shaped squares

B 22

		L (a)	SK	ZK	AM1	AM	G	
2-220532	double	93 mm	150 kN	15 kN	6 Nm	15 Nm	0,35 kg	48 £ •
2-220533	triple	111 mm	130 kN	15 kN	6 Nm	15 Nm	0,41 kg	54 £ •

**Connecting Bolt XL burnished**

to connect tables and U-squares, not suitable for aluminum profiles, not suitable for elongated holes, fixed long-term connection, hardened

B 22

		L (a)	SK	ZK	AM	G	
2-220563	double	58 mm	120 kN	15 kN	215 Nm	0,17 kg	21 £ •

**Magnetic Clamping Bolt Aluminum**

clamping without the use of tools, suitable for pressure-sensitive parts or when counterholding is not possible

AL 22

		HK	L (a)	SF	G	
2-220740		0,14 kN	60 mm	18 mm	0,06 kg	22 £ •

Style: double / triple / quadruple

You can find more information and accessories for these products online.



www.siegmond.com/
F-bolt22



Professional Screw Clamp burnished / nitrided

interchangeable prism, ball diameter spindle 10 mm, Trapezoid thread of spindle 16x4 mm, Vertical Bar reinforced



	SP	B (b)	H (c)	G	
2-220610.1	3,50 kN	220 mm	300 mm	2,65 kg	68 £ •



Professional Screw Clamp 45°/90° nitrided

interchangeable prism, ball diameter spindle 10 mm, Trapezoid thread of spindle 16x4 mm, stepless rotation from 0-360°, Vertical Bar reinforced



	SP	H (c)	G	
2-220630.1	3,50 kN	300 mm	2,12 kg	64 £ •



Professional Fast Tension Clamp burnished / nitrided

Vertical Bar reinforced



	SP	B (b)	H (c)	G	
2-220615	3,50 kN	275 mm	300 mm	2,36 kg	103 £ •



Pipe Clamp Universal burnished / nitrided

interchangeable prism, ball diameter spindle 10 mm, Trapezoid thread of spindle 16x4 mm, clamping at an angle of +/- 42°, fastening with an adjusting ring



	SP	B (b)	H (c)	G	
2-220604.1	1,40 kN	265 mm	210 mm	1,87 kg	75 £ •

Thread Bushing burnished

for 220610.1, Acme trapezoidal thread 16x4 mm for system 22 screw clamp arbor, usable in every system borehole



	H (c)	Ø	G	
2-220618	22 mm	24 mm	0,03 kg	8 £ •

Prism for Screw Clamps

for spindle with ball diameter 10 mm, compatible with 22 mm boreholes and clamps



	H (c)	Ø	G	
2-220657.1	20 mm	40 mm	0,09 kg	10 £ •
2-220658.E	20 mm	40 mm	0,09 kg	14 £ •
2-220659.PA	20 mm	40 mm	0,01 kg	9 £ •



Duo Prism Ø 40

for spindle with ball diameter 10 mm

	H (c)	Ø	G	
2-220650	27 mm	40 mm	0,13 kg	18 £ •
2-220650.A	27 mm	40 mm	0,05 kg	20 £ •
2-220650.PA	27 mm	40 mm	0,02 kg	19 £ •



You can find more information and accessories for these products online.



www.siegmund.com/
F-clamp22



Quick-Change Clamp 100

Length clamping arm 100 mm, Clamping range 0-100 mm, Mounting in system boreholes



	L (a)	B (b)	H (c)	G	
2-220706	340 mm	30 mm	150 mm	1,10 kg	70 £ •



Quick-Change Clamp 160

Length clamping arm 160 mm, Clamping range 0-140 mm, Mounting in system boreholes



	L (a)	B (b)	H (c)	G	
2-220707	360 mm	30 mm	150 mm	1,20 kg	70 £ •



Vertical clamp 1800 with Adapter

Adapter CS220715.4, for system borehole 22 mm



	SP	G	Special offer price
4-CS220790	1,80 kN	0,89 kg	53 £ • instead of 57 £



Vertical clamp 2200 with Adapter

Adapter CS220715.4, for system borehole 22 mm



	SP	G	Special offer price
4-CS220791	2,20 kN	1,16 kg	57 £ • instead of 61 £



Horizontal clamp 1800 with Adapter

Adapter CS220715.4, for system borehole 22 mm



	SP	G	Special offer price
4-CS220794	1,80 kN	0,89 kg	51 £ • instead of 54 £



Horizontal clamp 3000 with Adapter

Adapter CS220715.4, for system borehole 22 mm



	SP	G	Special offer price
4-CS220795	3 kN	1,19 kg	58 £ • instead of 62 £



Horizontal Toggle Clamp 2500 with Adapter

Adapter CS220715.4, for system borehole 22 mm



	SP	G	Special offer price
4-CS220792	2,50 kN	0,97 kg	65 £ • instead of 69 £



Horizontal Toggle Clamp 4000 with Adapter

Adapter CS220715.4, for system borehole 22 mm



	SP	G	Special offer price
4-CS220793	4 kN	1,46 kg	81 £ • instead of 87 £



Prism Ø 50 135° with screwed-in collar

M10 thread for e.g. prism extensions Item No. 220649, for pipes up to Ø 80 mm



		H (G)	Ø	G	
2-220648.1	22 B	20 mm	50 mm	0,26 kg	31 £ •
2-220648.1.A	22 AL	20 mm	50 mm	0,16 kg	36 £ •
2-220648.1.PA	22 PA	20 mm	50 mm	0,08 kg	40 £ •

Vario Prism Ø 50 90° / 120° with screwed-in collar

M10 thread for e.g. prism extensions Item No. 220649, for round and square pipes up to Ø 50 mm



		H (G)	Ø	G	
2-220645.1	22 B	20 mm	50 mm	0,30 kg	42 £ •
2-220645.1.A	22 AL	20 mm	50 mm	0,15 kg	42 £ •
2-220645.1.PA	22 PA	20 mm	50 mm	0,08 kg	42 £ •

Prism Ø 60 135° with screwed-in collar burnished

M10 thread for e.g. prism extensions Item No. 220649, for pipes up to Ø 80 mm



		H (G)	Ø	G	
2-220651.1	22 B	30 mm	60 mm	0,58 kg	34 £ •
2-220651.1.A	22 AL	30 mm	60 mm	0,32 kg	40 £ •
2-220651.1.PA	22 PA	30 mm	60 mm	0,13 kg	42 £ •

Prism Ø 80 90° with screwed-in collar

M10 thread for e.g. prism extensions Item No. 220649, for round and square pipes up to Ø 100 mm



		H (G)	Ø	G	
2-220647.1	22 B	40 mm	80 mm	1,07 kg	42 £ •
2-220647.1.A	22 AL	40 mm	80 mm	0,57 kg	48 £ •
2-220647.1.PA	22 PA	40 mm	80 mm	0,20 kg	51 £ •

Prism Ø 120 157° with screwed-in collar

M10 thread for e.g. prism extensions Item No. 220649, for pipes up to Ø 400 mm



		H (G)	Ø	G	
2-220652.1	22 B	30 mm	120 mm	1,74 kg	54 £ •
2-220652.1.A	22 AL	30 mm	120 mm	0,91 kg	70 £ •
2-220652.1.PA	22 PA	30 mm	120 mm	0,30 kg	76 £ •



Screw Support Ø 80 burnished

vernier adjustment height in a range of 75-110 mm, combinable with support set 220821 and prism extension



	H (G)	Ø	G	
2-220822	75-110 mm	80 mm	2,44 kg	65 £ •

Support height adjustable with scale burnished

incl. Set screw, height infinite adjustable between 20-105 mm, Set screw for connecting with prisms



	H (G)	Ø	G	
2-220824	134 mm	45 mm	0,52 kg	51 £ •

Prism Collar Screw with countersunk bolt burnished

to mount prisms in boreholes



	L (a)	Ø	G	
2-220669	12 mm	22 mm	0,04 kg	8 £ •

Set of Supports 11 pieces burnished

compensation of 1-100 mm height difference, with M10 thread



	H (G)	Ø	G	
2-220821	125 mm	50 mm	2,01 kg	53 £ •

Tower for Supports burnished

variable support surface, with M10 thread



	H (G)	Ø	G	
2-220821.1	125 mm	50 mm	0,39 kg	26 £ •

Washer Set

gradation of discs: 1 / 2 / 3 / 4 / 5 / 10 / 20 / 40 / 50 mm incl. 1/10" disc 2,54 mm



	Ø	G	
2-220821.2	50 mm	1,62 kg	26 £ •

Prism Extension burnished

compatible with prisms, support set 220821 and screw support 220822



	L (a)	Ø	G	
2-220649	25 mm	22 mm	0,07 kg	10 £ •
2-220649.1	50 mm	22 mm	0,14 kg	19 £ •
2-220649.2	100 mm	22 mm	0,28 kg	23 £ •
2-220649.3	150 mm	22 mm	0,42 kg	26 £ •



You can find more information and accessories for these products online.



www.siegmund.com/
F-prism22

Tool Cart powder coated finish

Max. total weight 240 kg

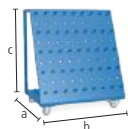

	L (a)	B (b)	H (c)	G	
2-220910	650 mm	900 mm	1020 mm	50 kg	792 £ •

Protective Welding Wall

mounting with 2 bolts (16: 000520, 22: 002822, 28: 280511), production-related not scratch proof, Custom color varnish available against surcharge



	L (a)	B (b)	H (c)	G	
2-280980	1600 mm	50 mm	800 mm	23 kg	213 £ •

Brush Ø 24 with protecting cover

for cleaning boreholes



	Ø	G	
2-220820	24 mm	0,06 kg	20 £ •

Brush Ø 24 for drill bit / 10 piece pack

for cleaning boreholes



	Ø	G	
2-220820.10	24 mm	0,06 kg	64 £ •

Hex wrench Size 5

yellow



	G	
2-220852	0,09 kg	17 £ •

Burner Holder burnished

can be positioned in borehole



	H (c)	G	
2-220920	200 mm	0,36 kg	26 £ •



Ground Connection Comfort

guarantees 100% contact to the welding table, Mounting in system boreholes, Load up to 500 ampere, Cable cross section 70-95 mm²



	G	
2-000810	0,66 kg	51 £ •

Lifting lug

for the safe transport of Siegmund welding tables and U-Squares, For fixing: System 28: 4x 280511, System 22: 4x 002822, Load capacity: 3000 kg (axial load)

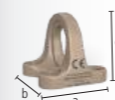

	L (a)	B (b)	H (c)	G	
2-280836	157 mm	157 mm	147 mm	6 kg	110 £ •



You can find more information and accessories for these products online.



www.siegmund.com/
F-accessories22

Professional 750 / Extreme 8.7

Sub Table Box lockable

powder coated finish, Storage space at your welding table, 360 mm space for drawers, lockable, incl. two keys

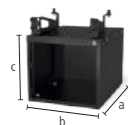

22

	L (a)	B (b)	H (c)	TF	G	
2-220990	630 mm	485 mm	430 mm	100 kg	30 kg	386 £ •

Set Sub Table Box lockable incl. 2 drawers

incl. drawers (2x 004230), powder coated finish, Storage space at your welding table, lockable, incl. two keys, delivered pre-assembled, drawer pull-out length 500 mm



22

	L (a)	B (b)	H (c)	TF	G	Special offer price
2-220990.1	630 mm	485 mm	430 mm	100 kg	44 kg	548 £ •

instead of 554 £

Set Sub Table Box lockable incl. 3 drawers

incl. drawers (1x 004220, 1x 004225, 1x 004230), powder coated finish, Storage space at your welding table, lockable, incl. two keys, delivered pre-assembled, drawer pull-out length 500 mm



22

	L (a)	B (b)	H (c)	TF	G	Special offer price
2-220990.2	630 mm	485 mm	430 mm	100 kg	49 kg	601 £ •

instead of 616 £

Extreme 8.7 PLUS

Sub Table Box lockable for PLUS Table

powder coated finish, Storage space at your welding table, 360 mm space for drawers, lockable, incl. two keys

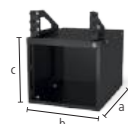

22

	L (a)	B (b)	H (c)	TF	G	
2-222990	630 mm	485 mm	430 mm	100 kg	29,90 kg	386 £ •

Set Sub Table Box lockable for PLUS Table incl. 2 drawers

incl. drawers (2x 004230), powder coated finish, Storage space at your welding table, lockable, incl. two keys, delivered pre-assembled, drawer pull-out length 500 mm



22

	L (a)	B (b)	H (c)	TF	G	Special offer price
2-222990.1	630 mm	485 mm	430 mm	100 kg	43,90 kg	548 £ •

instead of 554 £

Set Sub Table Box lockable for PLUS Table incl. 3 drawers

incl. drawers (1x 004220, 1x 004225, 1x 004230), powder coated finish, Storage space at your welding table, lockable, incl. two keys, delivered pre-assembled, drawer pull-out length 500 mm

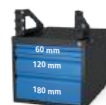

22

	L (a)	B (b)	H (c)	TF	G	Special offer price
2-222990.2	630 mm	485 mm	430 mm	100 kg	48,90 kg	601 £ •

instead of 616 £



You can find more information and accessories for these products online.



www.siegmund.com/
F-stbox

Configuration

Drawer with clip rail

powder coated finish, upgrading possible at any time, for Sub Table Box, for Workstation 0806 / 1208 / 1212 with side walls

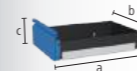

16 22 28

	L (a)	B (b)	H (c)	TF	G	
2-004220	590 mm	400 mm	60 mm	50 kg	5,50 kg	69 £ •
2-004225	590 mm	400 mm	120 mm	50 kg	6,50 kg	77 £ •
2-004230	590 mm	400 mm	180 mm	50 kg	7 kg	85 £ •
2-004235	590 mm	400 mm	240 mm	50 kg	7,50 kg	92 £ •



Bench vice 125

**Siegmund bench vice 125**

Fastening at a 45° or 90° angle, Jaw width 125 mm, Opening stroke 125 mm, Mounting: System 16: 2x 160511 + 2x 000546, System 22: 2x 220513 + 2x 000544, System 28: 2x 280511

16 22 28

2-004320

SP	G
30 kN	17,50 kg

266 £ •

**Set of vice jaw covers 125 incl. bag**

Delivery contents: 2x Fiber, 2x Rubber, 2x Aluminum neutral, 2x Aluminum prisms

16 22 28

2-004325

G
0,85 kg

59 £ •

**Set Siegmund bench vice 125 System 22**

Fastening at a 45° or 90° angle, Jaw width 125 mm, Opening stroke 125 mm, Delivery contents: 1x Bench vice 004320, 2x Bolt 220513, 2x Reduction Bushing 000544, 1x Set of vice jaw covers 004325

22

2-224320

SP	G
30 kN	19,19 kg

436 £ •

Bench vice 150

**Siegmund bench vice 150**

Fastening at a 45° or 90° angle, Jaw width 150 mm, Opening stroke 150 mm, Mounting: System 16: 2x 160511 + 2x 000546, System 22: 2x 220513 + 2x 000544, System 28: 2x 280511

16 22 28

2-004330

SP	G
40 kN	24 kg

345 £ •

**Set of vice jaw covers 150 incl. bag**

Delivery contents: 2x Fiber, 2x Rubber, 2x Aluminum neutral, 2x Aluminum prisms

16 22 28

2-004335

G
1 kg

67 £ •

**Set Siegmund bench vice 150 System 22**

Fastening at a 45° or 90° angle, Jaw width 150 mm, Opening stroke 150 mm, Delivery contents: 1x Bench vice 004330, 2x Bolt 220513, 2x Reduction Bushing 000544, 1x Set of vice jaw covers 004335

22

2-224330

SP	G
40 kN	25,84 kg

517 £ •

**Vice jaw covers**

The basic body of the vice jaw covers consists of solid aluminum profiles. The integrated magnets in the profiles hold the covers reliably on the vice and enable quick and easy changing, depending on the workpiece or processing step. Despite the very high magnetic force, workpieces are not magnetized. The vice jaw covers are right-angled and plane-parallel, which means that the high level of accuracy of the Siegmund vice keeps retained.

Set of vice jaw covers

2x Fiber: suitable for finely milled, finely planed, ground or polished surfaces, 2x Rubber: suitable for wooden and plastic parts, 2x Aluminum neutral: secure clamping of coarse to medium-fine machined workpieces thanks to grooves, 2x Aluminum prisms: Clamping of round or oval workpieces using prisms



You can find more information and accessories for these products online.



www.siegmund.com/
F-benchvice

**Table press System 22**

compressive force of 2,5 tons, total stroke 60 mm, operating force 330 N, fixation always required in two places

22

	G	
2-220780	6,70 kg	1.180 £ •

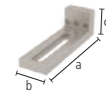
**Special Square System 22**

as an extension and vertical fixation of the press

22

	L (a)	B (b)	H (c)	G	
2-220702	195 mm	60 mm	60 mm	1,66 kg	79 £ •

Thrust Piece

000701.AL: recommended for steel work, 000701.PA: recommended for applications with stainless steel



	H (c)	Ø	G	
2-000701.AL	15 mm	55 mm	0,08 kg	24 £ •
2-000701.PA	15 mm	55 mm	0,03 kg	20 £ •

**Stamp 90° with extension pipe**

for pressing in corners without damaging the weld seam

16 22 28

	L (a)	B (b)	H (c)	G	
2-000706	168 mm	50 mm	50 mm	0,82 kg	103 £ •

**Pipe Adapter POM-C**

for straightening pipes, for pipes Ø 21,4 mm: 000703.1, for pipes Ø 26,9 mm: 000703.4, for pipes Ø 33,7 mm: 000703.2, for pipes Ø 42,4 mm: 000703.3

16 22 28

	L (a)	Ø	G	
2-000703.1	35 mm	55 mm	0,08 kg	23 £ •
2-000703.4	35 mm	55 mm	0,08 kg	23 £ •
2-000703.2	35 mm	55 mm	0,08 kg	23 £ •
2-000703.3	35 mm	55 mm	0,07 kg	23 £ •

**Pipe Bending Plug POM-C**

for bending and straightening pipes, for pipes Ø 21,4 mm: 000704.1, for pipes Ø 26,9 mm: 000704.4, for pipes Ø 33,7 mm: 000704.2, for pipes Ø 42,4 mm: 000704.3

16 22 28

	L (a)	B (b)	H (c)	G	
2-000704.1	120 mm	35 mm	60 mm	0,25 kg	42 £ •
2-000704.4	120 mm	35 mm	60 mm	0,26 kg	42 £ •
2-000704.2	120 mm	35 mm	60 mm	0,25 kg	42 £ •
2-000704.3	120 mm	35 mm	60 mm	0,23 kg	42 £ •

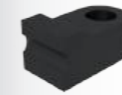
**Counter block POM-C**

as a counter block for bending and straightening pipes, Plug socket required for fastening, fastened with bolt 160515 / 220515 / 280513 (not included in the delivery), for pipes Ø 21,4 mm: 000705.1, for pipes Ø 26,9 mm: 000705.4, for pipes Ø 33,7 mm: 000705.2, for pipes Ø 42,4 mm: 000705.3

16 22 28

	L (a)	B (b)	H (c)	G	
2-000705.1	60 mm	114 mm	55 mm	0,37 kg	54 £ •
2-000705.4	60 mm	111 mm	55 mm	0,35 kg	53 £ •
2-000705.2	60 mm	102 mm	55 mm	0,31 kg	52 £ •
2-000705.3	60 mm	93 mm	55 mm	0,27 kg	48 £ •

**Plug socket**

for rotatable fastening of the counter block in the boreholes, for fixing: 220515

22

	L (a)	Ø	G	
2-220701	54 mm	40 mm	0,24 kg	20 £ •

Product recommendation**Basic-Set**

Included in the set: 1x 000701.PA, 1x 000701.AL, 1x 220702

22

	G	Special offer price
2-220783	1,77 kg	99 £ •
		instead of 124 £

**Pipe straightening set for Ø 21,4**

Included in the set: 1x 000703.1, 1x 000704.1, 2x 000705.1, 2x 220701, fastened with bolt 220515 (not included in the delivery)

22

	G	Special offer price
2-220782.1	1,55 kg	171 £ •
		instead of 213 £

**Pipe straightening set for Ø 26,9**

Included in the set: 1x 000703.4, 1x 000704.4, 2x 000705.4, 2x 220701, fastened with bolt 220515 (not included in the delivery)

22

	G	Special offer price
2-220782.4	1,52 kg	168 £ •
		instead of 210 £

**Pipe straightening set for Ø 33,7**

Included in the set: 1x 000703.2, 1x 000704.2, 2x 000705.2, 2x 220701, fastened with bolt 220515 (not included in the delivery)

22

	G	Special offer price
2-220782.2	1,43 kg	167 £ •
		instead of 209 £

**Pipe straightening set for Ø 42,4**

Included in the set: 1x 000703.3, 1x 000704.3, 2x 000705.3, 2x 220701, fastened with bolt 220515 (not included in the delivery)

22

	G	Special offer price
2-220782.3	1,32 kg	161 £ •
		instead of 201 £



You can find more information and accessories for these products online.



www.siegmond.com/
F-tablepress

FINE DETAILS FABRICATION

Our System 16 is the right decision for fine details fabrications, such as railings or frame constructions.

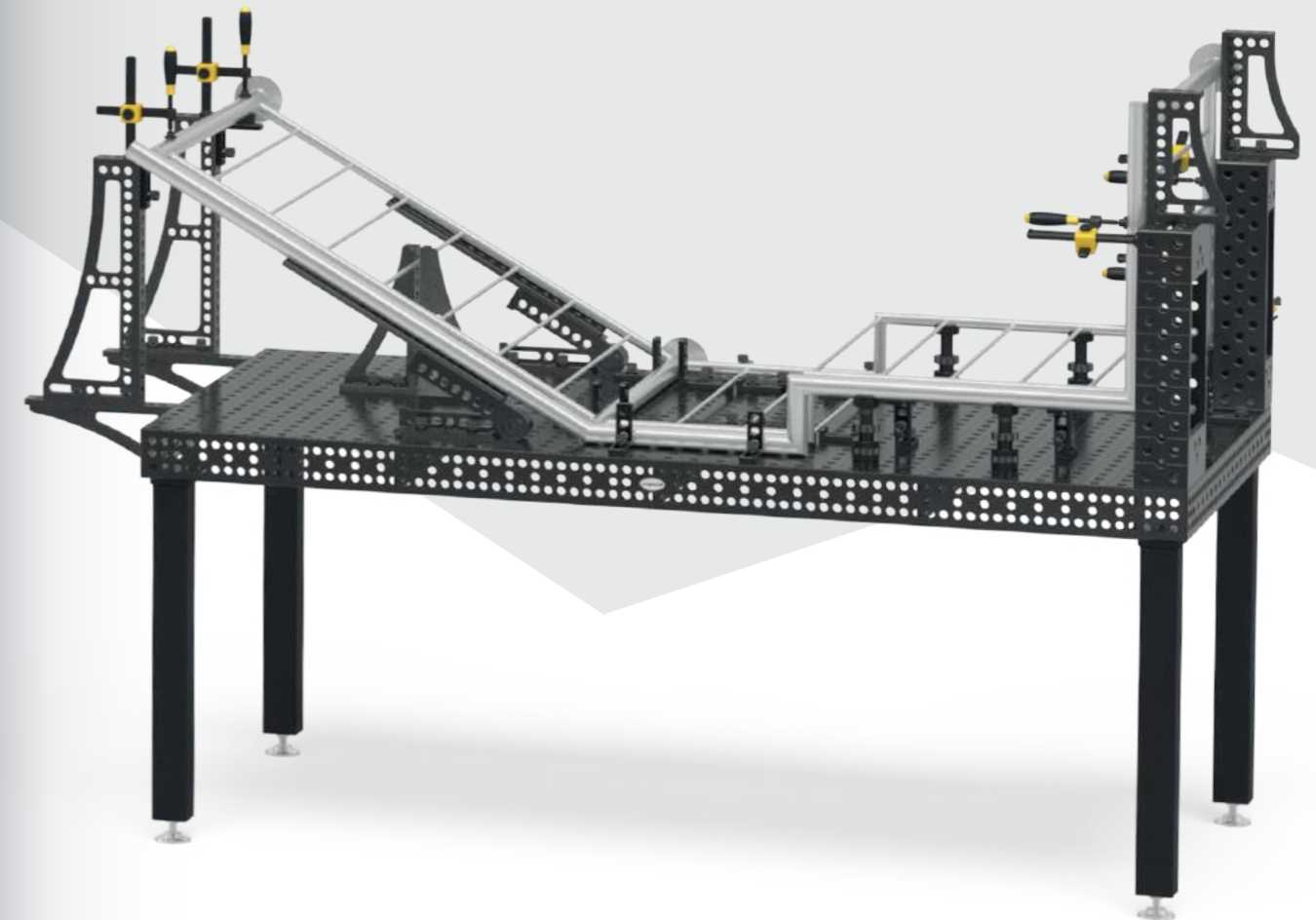
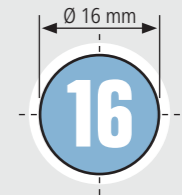

**Recommended load
up to 2000 kg**
max. 1000 kg per leg basic equipment

Basic 750

- premium steel S355J2+N, plasma nitrided and BAR-coated
- Material thickness approx. 11,5 – 13 mm
- Borehole Ø 16 mm, Boreholes on the surface 50x50 mm grid
- Height of table side 50 mm, Borehole spacing of table side 50 mm
- incl. leg standard equipment



Table size	Legs	Weight			
1000 x 1000 mm	4	183 kg	1.457 £	4-161010.P	•
1200 x 800 mm	4	173 kg	1.457 £	4-161025.P	•
1200 x 1200 mm	4	242 kg	1.900 £	4-161015.P	•
1500 x 1000 mm	4	244 kg	2.033 £	4-161035.P	•

Weight = Table Top + Pallet + Leg standard equipment
 Maximum recommended static total load with 4 legs 1000 kg based on even load distribution. (Data only for leg standard equipment)



www.siegmund.com/
F-tablebasic16



Table Legs



	Standard equipment	Height adjustable	Caster, locking brake	Height adjustable, caster, locking brake	Floor anchoring
	161856	4-160877.1.XX	4-161855.XX	4-160879.XX	4-160874.XX
Capacity per table leg	1000 kg	1000 kg	500 kg	500 kg	1000 kg
Leg height	815 mm	550 – 950 mm	815 mm	600 – 900 mm	815 mm
Fine adjustment	50 mm	40 mm	30 mm	30 mm	50 mm
Surcharge per leg	included	61 £	68 £	101 £	58 £

Working height = height of table leg + height of side panel of table
 The specified load capacities refer to static load. Note castor: Not recommended for welding tables with 6 table legs. Because of risk of tipping not permitted for 1200x800 mm tables.

Basic sets



	160610	160511	160420.N	160108.N	160110.N	160162.N	163999	
1	4-161200	4x	12x	8x	4x	2x	1x	960 £ •
2	4-161300	8x	16x	10x	4x	4x	2x	1.592 £ •

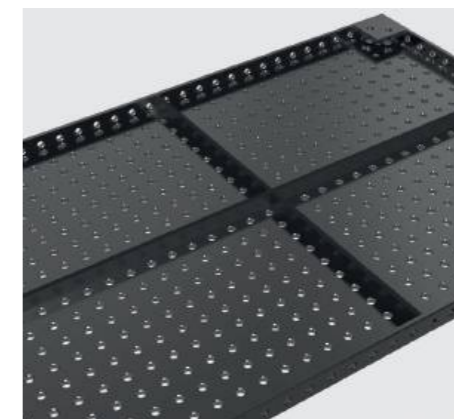

Professional 750

- premium steel S355J2+N, plasma nitrided and BAR-coated
- Material thickness approx. 11,5 – 13 mm
- Borehole Ø 16 mm, Boreholes on the surface 50x50 mm grid
- Height of table side 100 mm, Borehole spacing of table side 25 mm
- incl. leg standard equipment



Table size	Legs	Weight			
1200 x 1200 mm	4	261 kg	2.231 £	4-160015.P	•
1500 x 1000 mm	4	281 kg	2.365 £	4-160035.P	•
2000 x 1000 mm	4	354 kg	3.155 £	4-160020.P	•
2400 x 1200 mm	6	503 kg	4.322 £	4-160030.P	•
3000 x 1500 mm	6	758 kg	5.687 £	4-160040.P	•

Weight = Table Top + Pallet + Leg standard equipment
 Maximum recommended static total load with 4 legs 2000 kg based on even load distribution. (Data only for leg standard equipment)



www.siegmund.com/
F-table75016

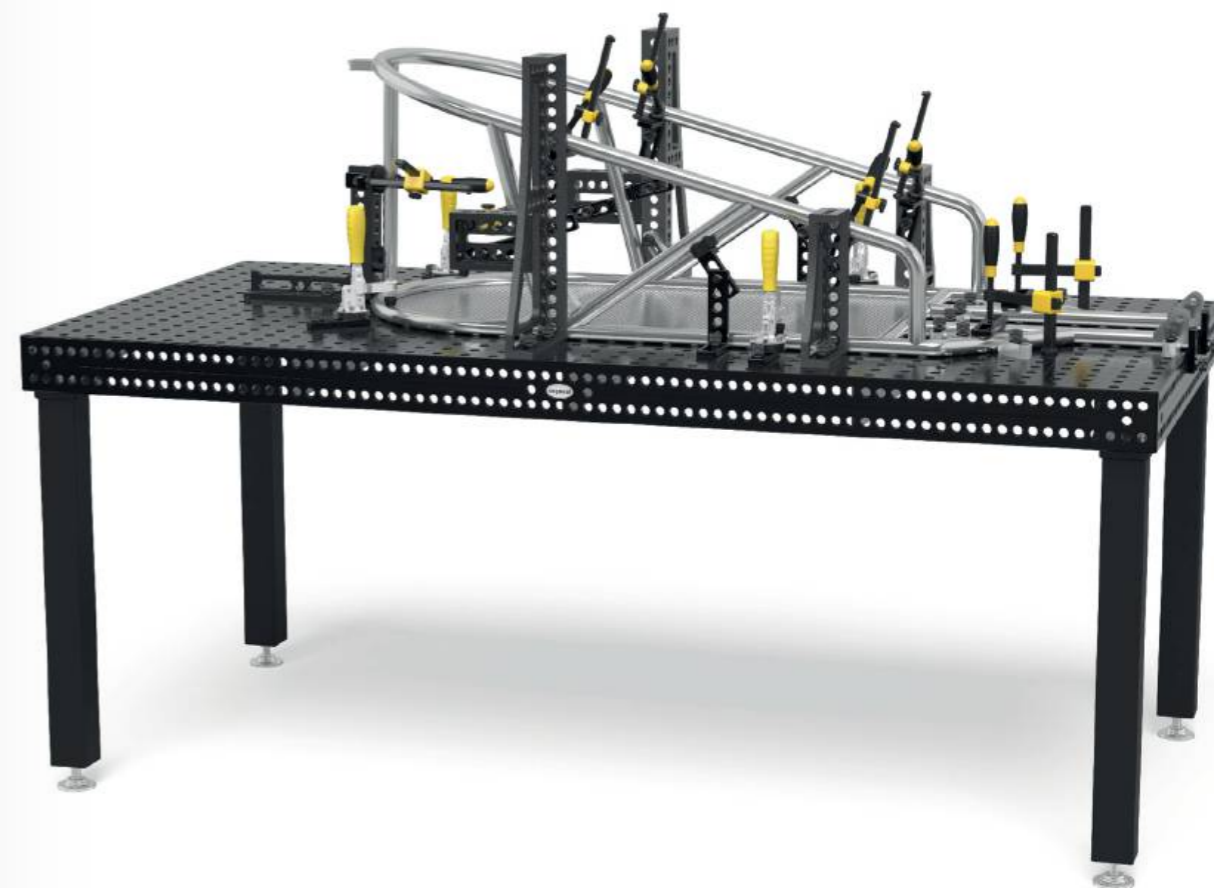

Table Legs



	Standard equipment	Standard equipment	Height adjustable	Caster, locking brake	Height adjustable, caster, locking brake	Floor anchoring
	160858.X	160857.X	4-160877.1.XX	4-160876.XX	4-160879.XX	4-160875.XX
Capacity per table leg	1000 kg	1000 kg	1000 kg	500 kg	500 kg	1000 kg
Leg height	750 mm	850 mm	550 – 950 mm	750 mm	600 – 900 mm	750 mm
Fine adjustment	40 mm	40 mm	40 mm	30 mm	30 mm	50 mm
Surcharge per leg	included	Alternatively	61 £	67 £	101 £	58 £

Working height = height of table leg + height of side panel of table
 The specified load capacities refer to static load. Note castor: Not recommended for welding tables with 6 or 8 table legs.

Sets



	160610	160630	160645.1.N	160511	160410.N	160420.N	160108.N
1	4-163100	4x		12x		4x	4x
2	4-163200	6x	2x	4x	18x	4x	6x
3	4-163300	8x	4x	4x	24x	4x	8x
4	4-163400	10x	4x	8x	30x	8x	10x
5	4-163500	12x	6x	8x	36x	8x	12x

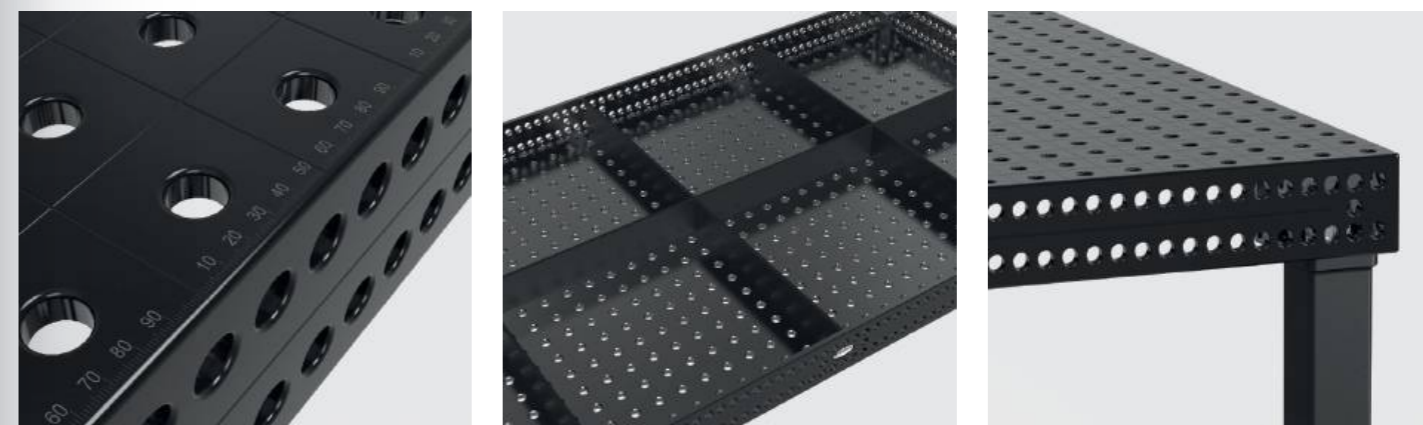

	160110.N	160162.N	160161+63.N	160134+36.N	160146+48.N	160910	163999	
	4x						1x	1.174 £ •
	6x	2x					1x	2.099 £ •
	8x	2x		1x			1x	3.109 £ •
	10x	4x	1x	1x		1x	1x	4.722 £ •
	12x	4x	1x	1x	1x	1x	1x	6.237 £ •

Professional Extreme 8.7

- Through-hardened tool steel X8.7, plasma nitrided and BAR-coated
- Material thickness approx. 11,5 – 13 mm
- Borehole Ø 16 mm, Boreholes on the surface 50x50 mm grid
- Height of table side 100 mm, Boreholes on table sides in diagonal grid
- Table side panel made of high quality steel S355J2+N
- incl. leg standard equipment



Table size	Legs	Weight			
1000 x 500 mm	4	126 kg	1.488 £	4-160005.X7D	•
1000 x 1000 mm	4	192 kg	1.971 £	4-160010.X7D	•
1200 x 800 mm	4	193 kg	2.106 £	4-160025.X7D	•
1200 x 1200 mm	4	259 kg	2.586 £	4-160015.X7D	•
1500 x 1000 mm	4	279 kg	2.720 £	4-160035.X7D	•
1500 x 1500 mm	4	394 kg	3.622 £	4-160050.X7D	•
2000 x 1000 mm	4	351 kg	3.567 £	4-160020.X7D	•
2000 x 1200 mm	4	412 kg	4.286 £	4-160060.X7D	•
2400 x 1200 mm	6	499 kg	5.024 £	4-160030.X7D	•
3000 x 1500 mm	6	753 kg	6.270 £	4-160040.X7D	•
4000 x 2000 mm	8	1255 kg	10.318 £	4-160055.X7D	•

Weight = Table Top + Pallet + Leg standard equipment
 Maximum recommended static total load with 4 legs 2000 kg based on even load distribution. (Data only for leg standard equipment)
 All tables are available on order without plasma nitriding. www.siegmund.com/F-tableX716



www.siegmund.com/F-tableX716



Table Legs



	Standard equipment	Standard equipment	Height adjustable	Caster, locking brake	Height adjustable, caster, locking brake	Floor anchoring
	160858.X	160857.X	4-160877.1.XX	4-160876.XX	4-160879.XX	4-160875.XX
Capacity per table leg	1000 kg	1000 kg	1000 kg	500 kg	500 kg	1000 kg
Leg height	750 mm	850 mm	550 – 950 mm	750 mm	600 – 900 mm	750 mm
Fine adjustment	40 mm	40 mm	40 mm	30 mm	30 mm	50 mm
Surcharge per leg	included	Alternatively	61 £	67 £	101 £	58 £

Working height = height of table leg + height of side panel of table
 The specified load capacities refer to static load. Note for castor: Not recommended for welding tables with 6 or 8 table legs. Because of risk of tipping not recommended for 1000x500 mm and 1200x800 mm.

Sets



	160610	160630	160645.1.N	160511	160410.N	160420.N	160108.N
1	4-163100	4x		12x		4x	4x
2	4-163200	6x	2x	18x	4x	6x	6x
3	4-163300	8x	4x	24x	4x	8x	8x
4	4-163400	10x	4x	30x	8x	10x	10x
5	4-163500	12x	6x	36x	8x	12x	12x

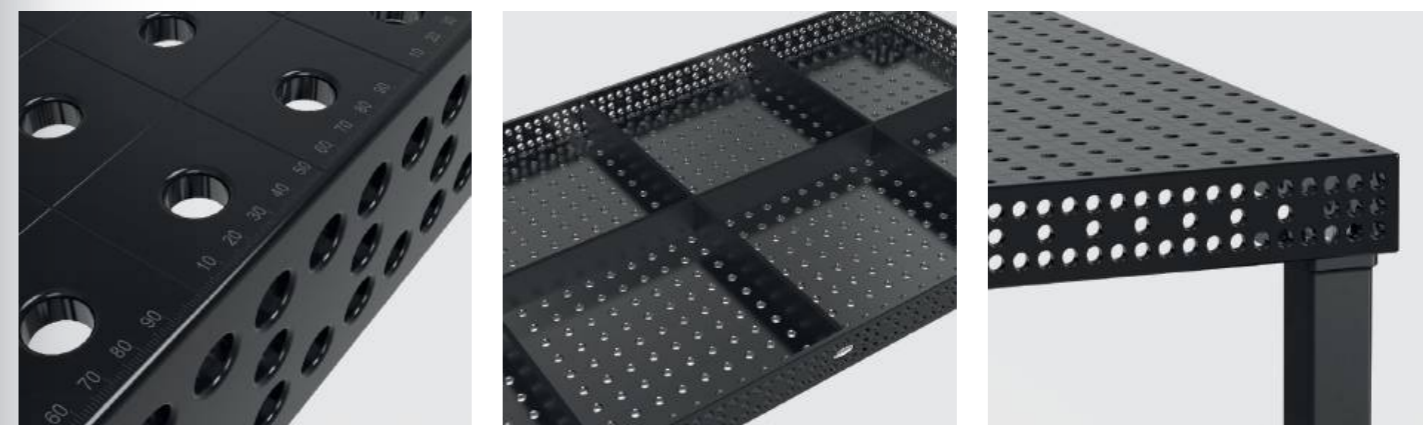

	160110.N	160162.N	160161+63.N	160134+36.N	160146+48.N	160910	163999	
	4x						1x	1.174 £ •
	6x	2x					1x	2.099 £ •
	8x	2x		1x			1x	3.109 £ •
	10x	4x	1x	1x		1x	1x	4.722 £ •
	12x	4x	1x	1x	1x	1x	1x	6.237 £ •

Professional Extreme 8.7 PLUS

- Through-hardened tool steel X8.7, plasma nitrided and BAR-coated
- Material thickness approx. 11,5 – 13 mm
- Borehole Ø 16 mm, Boreholes on the surface 50x50 mm grid
- Height of table side 150 mm, Boreholes on table side 3 rows with 25 mm spacing, 2 rows with 50 mm spacing
- Table side panel made of high quality steel S355J2+N
- incl. leg standard equipment



Table size	Legs	Weight			
1200 x 1200 mm	4	287 kg	2.872 £	4-160015.X7PL	•
1500 x 1000 mm	4	313 kg	2.992 £	4-160035.X7PL	•
2000 x 1000 mm	4	397 kg	3.971 £	4-160020.X7PL	•
2400 x 1200 mm	6	553 kg	5.581 £	4-160030.X7PL	•
3000 x 1500 mm	6	850 kg	6.925 £	4-160040.X7PL	•
4000 x 2000 mm	8	1457 kg	11.407 £	4-160055.X7PL	•



Weight = Table Top + Pallet + Leg standard equipment
 Maximum recommended static total load with 4 legs 2000 kg based on even load distribution. (Data only for leg standard equipment)
 All tables are available on order without plasma nitriding: www.siegmund.com/F-tableX716plus



www.siegmund.com/
F-tableX716plus



Table Legs



	Standard equipment	Standard equipment	Height adjustable	Caster, locking brake	Height adjustable, caster, locking brake	Floor anchoring
	160853.X	160857.X	4-160877.1.XX	4-160860.XX	4-160879.XX	4-160872.XX
Capacity per table leg	1000 kg	1000 kg	1000 kg	500 kg	500 kg	1000 kg
Leg height	700 mm	850 mm	550 – 950 mm	700 mm	600 – 900 mm	700 mm
Fine adjustment	40 mm	40 mm	40 mm	30 mm	30 mm	50 mm
Surcharge per leg	included	Alternatively	61 £	66 £	101 £	58 £

Working height = height of table leg + height of side panel of table
 The specified load capacities refer to static load. Note castor: Not recommended for welding tables with 6 or 8 table legs.

Sets



	160610	160630	160645.1.N	160511	160410.N	160420.N	160108.N
1	4-163100	4x		12x		4x	4x
2	4-163200	6x	2x	18x	4x	6x	6x
3	4-163300	8x	4x	24x	4x	8x	8x
4	4-163400	10x	4x	30x	8x	10x	10x
5	4-163500	12x	6x	36x	8x	12x	12x

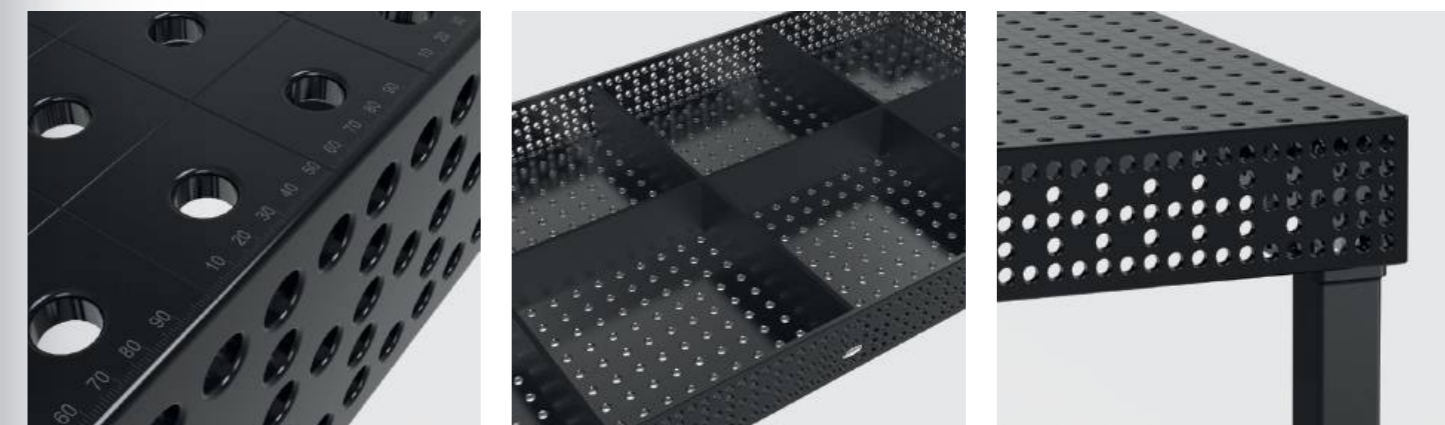

	160110.N	160162.N	160161+63.N	160134+36.N	160146+48.N	160910	163999	
	4x						1x	1.174 £ •
	6x	2x					1x	2.099 £ •
	8x	2x		1x			1x	3.109 £ •
	10x	4x	1x	1x		1x	1x	4.722 £ •
	12x	4x	1x	1x	1x	1x	1x	6.237 £ •

Siegmund lifting platform

- with two lifting cylinders
- high resilience
- easy handling
- massive scissors and steel rollers
- Contact strip protects against crushing
- Above-floor and underfloor installation possible



Model	L (a)	B (b)	G	Price
Lifting platform 2010 for 2000x1000 mm table, Overall height when retracted: 330 mm, Lifting range: 1100 mm, Lifting time loaded: 45~55 seconds, Force 2,2 kW, Operating voltage 400 V 50 Hz, Maximum load capacity: Basic frame (without a table) 4000 kg, incl. insulation plates	1990 mm	990 mm	470 kg	7.197 £
Lifting platform 2012 for 2000x1200 mm table, Overall height when retracted: 330 mm, Lifting range: 1100 mm, Lifting time loaded: 45~55 seconds, Force 2,2 kW, Operating voltage 400 V 50 Hz, Maximum load capacity: Basic frame (without a table) 4000 kg, incl. insulation plates	1990 mm	1190 mm	490 kg	7.461 £
Lifting platform 2412 for 2400x1200 mm table, Overall height when retracted: 330 mm, Lifting range: 1100 mm, Lifting time loaded: 45~55 seconds, Force 2,2 kW, Operating voltage 400 V 50 Hz, Maximum load capacity: Basic frame (without a table) 4000 kg, incl. insulation plates	2390 mm	1190 mm	530 kg	7.974 £
Lifting platform 3015 for 3000x1500 mm table, Overall height when retracted: 430 mm, Lifting range: 650 mm, Lifting time loaded: 35~45 seconds, Force 2,2 kW, Operating voltage 400 V 50 Hz, Maximum load capacity: Basic frame (without a table) 6000 kg, incl. insulation plates	2990 mm	1490 mm	865 kg	12.330 £

Lifting platform 2010 with welding table

- incl. welding table 2000x1000 mm and insulation plates
- Material thickness Table Top approx. 11,5 – 13 mm
- Dimensions (L x W): approx. 1990x990 mm
- Weight (without a table) approx. 470 kg
- Overall height when retracted: 330 mm, Lifting range: 1100 mm
- Working height is overall height plus table side panel
- Maximum load capacity: Basic frame (without a table) 4000 kg
- Lifting time loaded: 45~55 seconds
- Force 2,2 kW, Operating voltage 400 V 50 Hz



Size Working surface	Specifications Working surface	G	Price	Model
2000 x 1000 mm	16 750 N BAR	800 kg	10.076 £	4-HB160020.P
2000 x 1000 mm	16 XB.7 N BAR	797 kg	10.489 £	4-HB160020.X7D
2000 x 1000 mm	16 XB.7 N BAR	844 kg	10.892 £	4-HB160020.X7PL

Lifting platform 2012 with welding table

- incl. welding table 2000x1200 mm and insulation plates
- Material thickness Table Top approx. 11,5 – 13 mm
- Dimensions (L x W): approx. 1990x1190 mm
- Weight (without a table) approx. 490 kg
- Overall height when retracted: 330 mm, Lifting range: 1100 mm
- Working height is overall height plus table side panel
- Maximum load capacity: Basic frame (without a table) 4000 kg
- Lifting time loaded: 45~55 seconds
- Force 2,2 kW, Operating voltage 400 V 50 Hz



Size Working surface	Specifications Working surface	G	Price	Model
2000 x 1200 mm	16 XB.7 N BAR	878 kg	11.471 £	4-HB160060.X7D

Lifting platform 2412 with welding table

- incl. welding table 2400x1200 mm and insulation plates
- Material thickness Table Top approx. 11,5 – 13 mm
- Dimensions (L x W): approx. 2390x1190 mm
- Weight (without a table) approx. 530 kg
- Overall height when retracted: 330 mm, Lifting range: 1100 mm
- Working height is overall height plus table side panel
- Maximum load capacity: Basic frame (without a table) 4000 kg
- Lifting time loaded: 45~55 seconds
- Force 2,2 kW, Operating voltage 400 V 50 Hz



Size Working surface	Specifications Working surface	G	Price	Model
2400 x 1200 mm	16 750 N BAR	996 kg	11.882 £	4-HB160030.P
2400 x 1200 mm	16 XB.7 N BAR	992 kg	12.584 £	4-HB160030.X7D
2400 x 1200 mm	16 XB.7 N BAR	1048 kg	13.141 £	4-HB160030.X7PL

Lifting platform 3015 with welding table

- incl. welding table 3000x1500 mm and insulation plates
- Material thickness Table Top approx. 11,5 – 13 mm
- Dimensions (L x W): approx. 2990x1490 mm
- Weight (without a table) approx. 865 kg
- Overall height when retracted: 430 mm, Lifting range: 650 mm
- Working height is overall height plus table side panel
- Maximum load capacity: Basic frame (without a table) 6000 kg
- Lifting time loaded: 34~45 seconds
- Force 2,2 kW, Operating voltage 400 V 50 Hz



Size Working surface	Specifications Working surface	G	Price	Model
3000 x 1500 mm	16 750 N BAR	1586 kg	17.603 £	4-HB160040.P
3000 x 1500 mm	16 XB.7 N BAR	1581 kg	18.186 £	4-HB160040.X7D
3000 x 1500 mm	16 XB.7 N BAR	1680 kg	18.841 £	4-HB160040.X7PL



You can find more information and accessories for these products online.



www.siegmund.com/
F-h-lift

Rotating table height adjustable static

- Dimensions (L x W): approx. 785x785 mm
- Weight (without plate): approx. 70 kg
- Working height between 780 mm and 1100 mm
- Due to the danger of tipping, we exclusively recommend the sizes shown
- Only compatible with specified worktops (special attachment points in the worktop)
- Maximum load capacity: Basic frame (without plate) 1000 kg



Size Working surface	Specifications Working surface	MS (d)	G			
1000 x 1000 mm	16 750 N BAR	12 mm	192 kg	2.311 £	2-DS161010.P	•
1200 x 800 mm	16 750 N BAR	12 mm	182 kg	2.311 £	2-DS161025.P	•
1200 x 1200 mm	16 750 N BAR	12 mm	238 kg	2.753 £	2-DS161015.P	•
1000 x 1000 mm	16 XB.7 N BAR	12 mm	160 kg	1.865 £	2-DS164024.X7	•
1200 x 800 mm	16 XB.7 N BAR	12 mm	158 kg	1.840 £	2-DS164004.X7	•
1200 x 1200 mm	16 XB.7 N BAR	12 mm	201 kg	2.221 £	2-DS164034.X7	•
Ø 1000 mm	16 XB.7 N BAR	12 mm	142 kg	1.913 £	2-DS164210.X7	•

Rotating table height adjustable portable

- Dimensions (L x W): approx. 795x795 mm
- Weight (without plate): approx. 70 kg
- Working height between 780 mm and 1100 mm
- Due to the danger of tipping, we exclusively recommend the sizes shown
- Only compatible with specified worktops (special attachment points in the worktop)
- Maximum load capacity: Basic frame (without plate) 1000 kg



Size Working surface	Specifications Working surface	MS (d)	G			
1000 x 1000 mm	16 750 N BAR	12 mm	192 kg	2.453 £	2-DM161010.P	•
1200 x 800 mm	16 750 N BAR	12 mm	182 kg	2.453 £	2-DM161025.P	•
1200 x 1200 mm	16 750 N BAR	12 mm	238 kg	2.895 £	2-DM161015.P	•
1000 x 1000 mm	16 XB.7 N BAR	12 mm	160 kg	2.006 £	2-DM164024.X7	•
1200 x 800 mm	16 XB.7 N BAR	12 mm	158 kg	1.982 £	2-DM164004.X7	•
1200 x 1200 mm	16 XB.7 N BAR	12 mm	201 kg	2.363 £	2-DM164034.X7	•
Ø 1000 mm	16 XB.7 N BAR	12 mm	142 kg	2.055 £	2-DM164210.X7	•

Magnetic ground connection

Magnetic ground connection with rotary joint for a high holding force on clean and smooth surfaces. No more twisting cables thanks to the quick and easy grounding. Connection can be clamped or hard-wired. In combination with an adapter plate and countersunk-head screw, it is perfectly suited as a retrofit set for the rotating table.



Magnetic ground connection for rotating table

quick and easy grounding, no cable twisting, high holding force on clean and smooth surfaces, Delivery contents: Adapter plate and countersunk-head screw

16 22 28

	MS (d)	G	
2-00003399	12 mm	0,92 kg	40 £ •

You can find more information and accessories for these products online. www.siegmund.com/F-rotating

Mobile lifting table 500 kg

- Dimensions (L x W): approx. 1115x630 mm
- Weight (without plate): approx. 65 kg
- Working height from approx. 700 to 1000 mm
- Only compatible with specified worktops (special attachment points in the worktop)
- Maximum load capacity: Basic frame (without plate) 500 kg



Size Working surface	Specifications Working surface	MS (d)	G			
1200 x 800 mm	16 750 N BAR	12 mm	177 kg	2.750 £	2-HT161025.P	•
1500 x 1000 mm	16 750 N BAR	12 mm	231 kg	3.325 £	2-HT161035.P	•
1200 x 800 mm	16 XB.7 N BAR	12 mm	153 kg	2.279 £	2-HT164004.X7	•
1500 x 1000 mm	16 XB.7 N BAR	12 mm	200 kg	2.742 £	2-HT164014.X7	•

Mobile lifting table 1000 kg

- Dimensions (L x W): approx. 1490x990 mm
- Weight (without plate): approx. 200 kg
- Working height from approx. 700 to 1000 mm
- Fastening via the boreholes
- Maximum load capacity: Basic frame (without plate) 1000 kg



Size Working surface	Specifications Working surface	MS (d)	G			
1500 x 1000 mm	16 750 N BAR	12 mm	366 kg	3.786 £	2-HS161035.P	•
1500 x 1000 mm	16 XB.7 N BAR	12 mm	335 kg	3.203 £	2-HS164014.X7	•
2000 x 1000 mm	16 XB.7 N BAR	12 mm	379 kg	3.608 £	2-HS164044.X7	•
1500 x 1000 mm	16 750 N BAR	12 mm	405 kg	4.118 £	2-HS160035.P	•

Mobile lifting table 1200 kg

- Dimensions (L x W): approx. 1490x990 mm
- Weight (without plate): approx. 210 kg
- Working height from approx. 700 to 1000 mm
- Maximum load capacity: Basic frame (without plate) 1200 kg



Size Working surface	Specifications Working surface	MS (d)	G			
1500 x 1000 mm	16 XB.7 N BAR	12 mm	413 kg	5.314 £	2-HS160035.X7D	•

Product recommendation



Supplementary set, load-bearing capacity 1700 kg

Second lifting cylinder for 1700 kg load-bearing capacity (minus plate), Only compatible with mobile lifting table 1200 kg, Scope of delivery: 1x lifting cylinder, 1x foot pedal, fastening material

16 22 28

	MS (d)	G	
2-HS009921	12 mm	4 kg	474 £ •

You can find more information and accessories for these products online. www.siegmund.com/F-lifting

Siegmond Workstation 0806

- 600 mm space for drawers
- incl. Perforated plate 800x600 mm
- Through-hardened tool steel X8.7, plasma nitrided and BAR-coated
- Material thickness approx. 12 mm
- Borehole Ø 16 mm
- Boreholes on the surface 50x50 mm grid
- Maximum load capacity: base plate 400 kg (without plate)



Siegmond Workstation 0806

As a small workstation for work preparation or as an extension table for the Workstation 1208., Delivery contents: 1x 004902 Siegmond Workstation 0806 Basic frame, 1x 164009.X7 Perforated plate



	L (a)	B (b)	H (c)	G	Special offer price
2-164900	800 mm	600 mm	850 mm	60,90 kg	898 £ • instead of 919 £

Siegmond Workstation 0806 incl. Drawer

As a small workstation for work preparation or as an extension table for the Workstation 1208., Delivery contents: 1x 004902 Siegmond Workstation 0806 Basic frame, 1x 164009.X7 Perforated plate, 1x 004225.WS Drawer 120 mm



	L (a)	B (b)	H (c)	G	Special offer price
2-164903	800 mm	600 mm	850 mm	69,90 kg	1.013 £ • instead of 1.016 £

Siegmond Workstation 0806 closed incl. 3 drawers

As a small workstation for work preparation or as an extension table for the Workstation 1208., Delivery contents: 1x 004902 Siegmond Workstation 0806 Basic frame, 1x 164009.X7 Perforated plate, 2x 004230 Drawer 180 mm, 1x 004235 Drawer 240 mm, 1x 004920 Set side walls



	L (a)	B (b)	H (c)	G	Special offer price
2-164907	800 mm	600 mm	850 mm	95,40 kg	1.328 £ • instead of 1.354 £

plus packaging / Shipping

Siegmond Workstation 0806 – Configuration

Drawer with clip rail and mounting for Workstation 0806 / 1208

powder coated finish, upgrading possible at any time, for Workstation 0806 / 1208 without side walls, mounting is required if there are no side walls in the Workstation

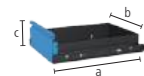

	L (a)	B (b)	H (c)	TF	G	Special offer price
2-004220.WS	590 mm	400 mm	60 mm	50 kg	7,50 kg	87 £ •
2-004225.WS	590 mm	400 mm	120 mm	50 kg	9 kg	98 £ •
2-004230.WS	590 mm	400 mm	180 mm	50 kg	9,50 kg	109 £ •
2-004235.WS	590 mm	400 mm	240 mm	50 kg	10 kg	120 £ •

Siegmond Workstation 1208

- left and right 600 mm space for drawers
- incl. Perforated plate 1200x800 mm
- Through-hardened tool steel X8.7, plasma nitrided and BAR-coated
- Material thickness approx. 12 mm
- Borehole Ø 16 mm
- Boreholes on the surface 50x50 mm grid
- Maximum load capacity: base plate 1000 kg (without plate) / Castor 400 kg (without plate)



Siegmond Workstation 1208

Delivery contents: 1x 004002.1 Siegmond Workstation 1208 Basic frame, 1x 164004.X7 Perforated plate



	L (a)	B (b)	H (c)	G	Special offer price
2-164400	1200 mm	800 mm	850 mm	120 kg	1.293 £ • instead of 1.317 £

Siegmond Workstation 1208 incl. Shelves

Delivery contents: 1x 004002.1 Siegmond Workstation 1208 Basic frame, 1x 164004.X7 Perforated plate, 1x 164030 Clamp holder, 1x 004620 Shelf, 1x 164635 Bolt and prism holder, 1x 004025.1 Toolwall incl. Shelf



	L (a)	B (b)	H (c)	G	Special offer price
2-164401	1200 mm	800 mm	850 mm	129,78 kg	1.428 £ • instead of 1.461 £

Siegmond Workstation 1208 half closed incl. 3 drawers

Delivery contents: 1x 004002.1 Siegmond Workstation 1208 Basic frame, 1x 164004.X7 Perforated plate, 2x 004230 Drawer 180 mm, 1x 004235 Drawer 240 mm, 1x 004120 Set side walls



	L (a)	B (b)	H (c)	G	Special offer price
2-164407	1200 mm	800 mm	850 mm	152,50 kg	1.724 £ • instead of 1.752 £

Siegmond Workstation 1208 closed incl. 6 drawers

Delivery contents: 1x 004002.1 Siegmond Workstation 1208 Basic frame, 1x 164004.X7 Perforated plate, 4x 004230 Drawer 180 mm, 2x 004235 Drawer 240 mm, 2x 004120 Set side walls



	L (a)	B (b)	H (c)	G	Special offer price
2-164409	1200 mm	800 mm	850 mm	185 kg	2.154 £ • instead of 2.188 £

plus packaging / Shipping

Siegmond Workstation 1208 – Configuration

Equipment with 4 castors for Workstation 1208

switch between feet and casters possible



	TF	G	Special offer price
2-004100.1	400 kg	5,30 kg	78 £ •

Drawer with clip rail and mounting for Workstation 0806 / 1208

powder coated finish, upgrading possible at any time, for Workstation 0806 / 1208 without side walls, mounting is required if there are no side walls in the Workstation



	L (a)	B (b)	H (c)	TF	G	Special offer price
2-004220.WS	590 mm	400 mm	60 mm	50 kg	7,50 kg	87 £ •
2-004225.WS	590 mm	400 mm	120 mm	50 kg	9 kg	98 £ •
2-004230.WS	590 mm	400 mm	180 mm	50 kg	9,50 kg	109 £ •
2-004235.WS	590 mm	400 mm	240 mm	50 kg	10 kg	120 £ •



You can find more information and accessories for these products online.



www.siegmond.com/
F-workstation

Siegmund Workstation 1212

- left and right 600 mm space for drawers
- incl. Perforated plate 1200x1200 mm
- Through-hardened tool steel X8.7, plasma nitrided and BAR-coated
- Material thickness approx. 12 mm
- Borehole Ø 16 mm
- Boreholes on the surface 50x50 mm grid
- Maximum load capacity: base plate 1000 kg (without plate) / Castor 400 kg (without plate)



Siegmund Workstation 1212

Delivery contents: 1x 004602 Siegmund Workstation 1212 Basic frame, 1x 164034.1.X7 Perforated plate



	L (a)	B (b)	H (c)	G	Special offer price
2-164600	1200 mm	1200 mm	850 mm	174,80 kg	1.694 £ • instead of 1.715 £



Siegmund Workstation 1212 incl. Shelves

Delivery contents: 1x 004602 Siegmund Workstation 1212 Basic frame, 1x 164034.1.X7 Perforated plate, 1x 164630 Clamp holder, 1x 004620 Shelf, 1x 164635 Bolt and prism holder, 1x 004625 Toolwall incl. Shelf



	L (a)	B (b)	H (c)	G	Special offer price
2-164601	1200 mm	1200 mm	850 mm	187,55 kg	1.838 £ • instead of 1.869 £



Siegmund Workstation 1212 half closed incl. 3 drawers

Delivery contents: 1x 004602 Siegmund Workstation 1212 Basic frame, 1x 164034.1.X7 Perforated plate, 2x 004230 Drawer 180 mm, 1x 004235 Drawer 240 mm, 1x 004720 Set side walls



	L (a)	B (b)	H (c)	G	Special offer price
2-164607	1200 mm	1200 mm	850 mm	208,80 kg	2.132 £ • instead of 2.158 £



Siegmund Workstation 1212 closed incl. 6 drawers

Delivery contents: 1x 004602 Siegmund Workstation 1212 Basic frame, 1x 164034.1.X7 Perforated plate, 4x 004230 Drawer 180 mm, 2x 004235 Drawer 240 mm, 2x 004720 Set side walls



	L (a)	B (b)	H (c)	G	Special offer price
2-164609	1200 mm	1200 mm	850 mm	242,80 kg	2.570 £ • instead of 2.602 £

plus packaging / Shipping

Siegmund Workstation 1212 – Configuration



Equipment with 4 castors for Workstation 1212

switch between feet and casters possible



	TF	G	Special offer price
2-004700	400 kg	4,30 kg	86 £ •

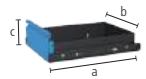

Drawer with clip rail and mounting for Workstation 1212

powder coated finish, upgrading possible at any time, for Workstation 1212 without side walls, mounting is required if there are no side walls in the Workstation



	L (a)	B (b)	H (c)	TF	G	Special offer price
2-004820.WS	590 mm	400 mm	60 mm	50 kg	8 kg	92 £ •
2-004825.WS	590 mm	400 mm	120 mm	50 kg	9,50 kg	103 £ •
2-004830.WS	590 mm	400 mm	180 mm	50 kg	10 kg	114 £ •
2-004835.WS	590 mm	400 mm	240 mm	50 kg	10,50 kg	125 £ •

Product recommendation



Tool-Set A

2x 160620 Clamp, 6x 160511 Bolt, 4x 160412 Stop, 1x 160852 Hex wrench



	G	Special offer price
2-167320	2,64 kg	310 £ • instead of 400 £



Tool-Set B

4x 160620 Clamp, 8x 160511 Bolt, 6x 160412 Stop, 2x 160108.N Square, 1x 160852 Hex wrench, 1x 164310 Bench vice incl. Set of vice jaw covers



	G	Special offer price
2-167340.1	15,54 kg	656 £ • instead of 1.010 £



Tool-Set C

6x 160620 Clamp, 10x 160511 Bolt, 8x 160412 Stop, 2x 160108.N Square, 2x 164050 Extension for perforated plates, 2x 160528 Flush Mount Bolt, 1x 160852 Hex wrench, 1x 164310 Bench vice incl. Set of vice jaw covers



	G	Special offer price
2-167360	21,78 kg	959 £ • instead of 1.371 £



Set External stop bracket for perforated plates

Consisting of: 1x 164051 External stop bracket for perforated plates incl. 2 set screws, 1x 160528 Flush Mount double



	L (a)	L (a1)	B (b)	H (c)	G	Special offer price
2-164051.Set	282 mm	250 mm	49 mm	112 mm	2,04 kg	65 £ • instead of 85 £

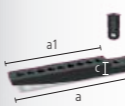

Set Extension for perforated plates 1 row of holes

Consisting of: 1x 164050 Extension for perforated plates 1 row of holes incl. 2 set screws, 1x 160528 Flush Mount Bolt double



	L (a)	L (a1)	B (b)	H (c)	G	Special offer price
2-164050.Set	331 mm	250 mm	49 mm	32,50 mm	2,04 kg	65 £ • instead of 85 £



Set Extension for perforated plates 2 rows of holes

Consisting of: 1x 164055 Extension for perforated plates 2 rows of holes incl. 4 set screws, 2x 160528 Flush Mount Bolt double



	L (a)	L (a1)	B (b)	H (c)	G	Special offer price
2-164055.Set	331 mm	250 mm	99 mm	32,50 mm	3,28 kg	98 £ • instead of 144 £



Octagonal Table 100

fixation via adapter plate (not included in the scope of delivery), Adapter plate available on request at an additional cost, Discount: starting at 2 pieces: 5%, starting at 5 pieces: 10%

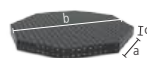

	L (a)	B (b)	H (c)	MS (d)	Ø	G	
2-920616.P	249 mm	600 mm	100 mm	12 mm	650 mm	98 kg	2.995 £ ◦
2-920816.P	331 mm	800 mm	100 mm	12 mm	866 mm	131 kg	4.417 £ ◦
2-921016.P	414 mm	1000 mm	100 mm	12 mm	1082 mm	171 kg	5.284 £ ◦
2-921216.P	497 mm	1200 mm	100 mm	12 mm	1299 mm	229 kg	6.651 £ ◦

Octagonal Table 50

fixation via adapter plate (not included in the scope of delivery), Adapter plate available on request at an additional cost, Discount: starting at 2 pieces: 5%, starting at 5 pieces: 10%



	L (a)	B (b)	H (c)	MS (d)	Ø	G	
2-920616.1.P	249 mm	600 mm	50 mm	12 mm	650 mm	80 kg	2.696 £ ◦
2-920816.1.P	331 mm	800 mm	50 mm	12 mm	866 mm	104 kg	3.975 £ ◦
2-921016.1.P	414 mm	1000 mm	50 mm	12 mm	1082 mm	139 kg	4.755 £ ◦
2-921216.1.P	497 mm	1200 mm	50 mm	12 mm	1299 mm	188 kg	5.985 £ ◦

Octagonal Plate

fixation through bore holes using support sleeves (160500), M8 thread on the side, Discount: starting at 2 pieces: 5%, starting at 5 pieces: 10%



	L (a)	B (b)	H (c)	MS (d)	Ø	G	
2-950500.P	207 mm	500 mm	12 mm	12 mm	542 mm	54 kg	1.756 £ ◦
2-950600.P	249 mm	600 mm	12 mm	12 mm	650 mm	63 kg	1.950 £ ◦
2-950800.P	331 mm	800 mm	12 mm	12 mm	866 mm	84 kg	2.875 £ ◦
2-951000.P	414 mm	1000 mm	12 mm	12 mm	1083 mm	111 kg	3.439 £ ◦
2-951200.P	497 mm	1200 mm	12 mm	12 mm	1299 mm	157 kg	4.329 £ ◦

Weight = Octagonal Plate + Pallet
 Due to customer specific adaptation the weight can vary.
 Further table sizes are available on request.
 Foot plates or adapter plates are not included as standard in the octagonal tables.

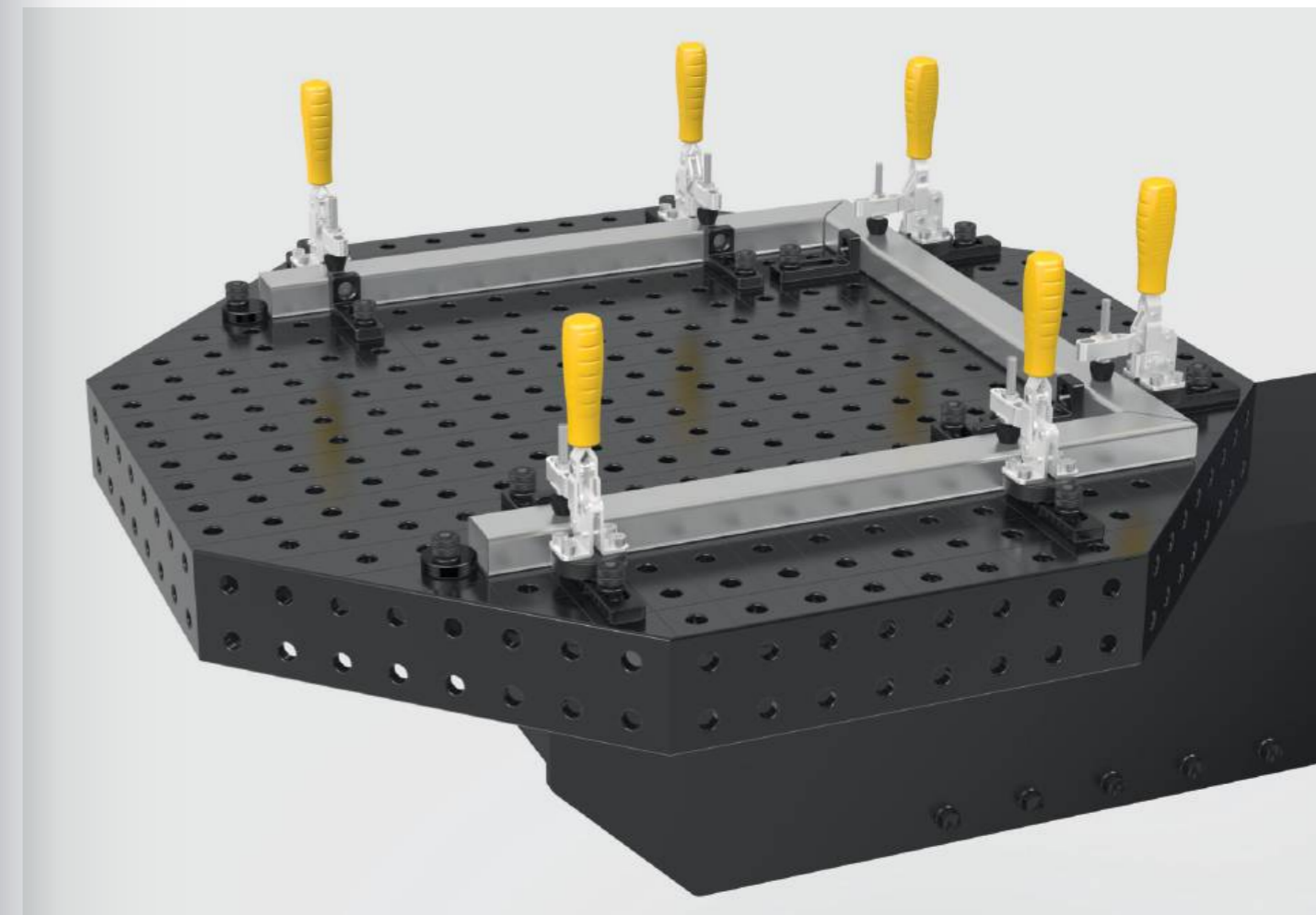

Adapter plate available on request at an additional cost

To connect the Octagonal Table with a positioner, an adapter plate is required. Upon request, the adapter plate with special connecting hole pattern can be custom-made against a surcharge.



Surcharge for customizing Adapter Plate
 for octagonal tables with side panels

16 22 28

0-940000

719 £ ◦

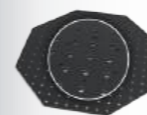

Surcharge for customization of the drill circle
 for octagonal plates

16 22 28

0-940000.1

535 £ ◦



You can find more information and accessories for these products online.



www.siegmund.com/
 F-octagonal16

Eccentric Stop Ø 45 / Ø 75 nitrided
stepless adjusting



	MS (d)	Ø	G	
2-160401.N	12 mm	45 mm	0,13 kg	18 £ •
2-160403.N	12 mm	75 mm	0,39 kg	22 £ •

Eccentric Stop Ø 75 with M10 thread nitrided
for ground connection, stepless adjusting



	MS (d)	Ø	G	
2-160402.N	12 mm	75 mm	0,38 kg	23 £ •

Universal Stop 50 L / 80 L nitrided
with boreholes, no elongated hole, Borehole spacing 25 mm



	L (a)	B (b)	MS (d)	G	
2-160407.N	50 mm	30 mm	12 mm	0,08 kg	23 £ •
2-160408.N	80 mm	30 mm	12 mm	0,16 kg	25 £ •

Universal Stop 80 L nitrided
elongated hole



	L (a)	B (b)	VB (f)	MS (d)	G	
2-160410.N	80 mm	30 mm	50 mm	12 mm	0,07 kg	35 £ •

Flex Stop 12x83 Aluminum
elongated hole, Especially suitable for components made of stainless steel



	L (a)	B (b)	VB (f)	MS (d)	WS (d1)	G	
2-160412	83 mm	31 mm	50 mm	12 mm	8 mm	0,05 kg	19 £ •

Flex Stop 12x78 / 12x97 Steel Galvanized
elongated hole



	L (a)	B (b)	VB (f)	MS (d)	WS (d1)	G	
2-160415	78 mm	28 mm	50 mm	12 mm	6 mm	0,07 kg	18 £ •
2-160417	97 mm	24 mm	71 mm	12 mm	4 mm	0,08 kg	32 £ •

Flex Stop 24x78 Steel Galvanized
long clamping bolt required, elongated hole

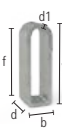

	L (a)	B (b)	VB (f)	MS (d)	WS (d1)	G	
2-160416	78 mm	28 mm	50 mm	24 mm	6 mm	0,13 kg	24 £ •

Universal Stop 115 L / 150 L nitrided
combination of borehole and elongated hole, for use with both prisms and adapters



	L (a)	B (b)	VB (f)	MS (d)	G	
2-160420.N	115 mm	30 mm	50 mm	12 mm	0,20 kg	42 £ •
2-160422.N	150 mm	35 mm	50 mm	12 mm	0,33 kg	47 £ •



You can find more information and accessories for these products online.



www.siegmund.com/
F-stop16



Universal Stop 115 L Aluminum

combination of borehole and elongated hole, for use with both prisms and adapters



	L (a)	B (b)	VB (f)	MS (d)	G	
2-160420.A	115 mm	30 mm	50 mm	12 mm	0,05 kg	36 £ •



Universal Stop / Clamping Bridge nitrided

combination of borehole and elongated hole, usable as clamping bridge, can be fixed with screw clamp



	L (a)	B (b)	VB (f)	MS (d)	G	
2-160450.N	175 mm	35 mm	50 mm	12 mm	0,40 kg	51 £ •



Universal Stop 300 M / 500 M nitrided

combination of borehole and elongated hole



	L (a)	B (b)	VB (f)	MS (d)	G	
2-160425.N	300 mm	50 mm	100 mm	12 mm	1,08 kg	53 £ •
2-160432.N	500 mm	50 mm	150 mm	12 mm	1,85 kg	81 £ •



Flat Square 250 burnished

combination of borehole and elongated hole, for 90 degree setting



	L (a)	B (b)	H (c)	MS (d)	G	
2-160444	250 mm	188 mm	50 mm	12 mm	1,35 kg	105 £ •



Angle Alignment Template nitrided

incl. 2x Spacer Sleeve, infinite adjustment from 0-90°



	L (a)	B (b)	MS (d)	G	
2-160455.N	130 mm	130 mm	5 mm	0,40 kg	45 £ •



Stop and Clamping Square 50 L / 90 VL nitrided
with boreholes, no elongated hole

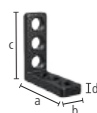

	L (a)	B (b)	H (c)	MS (d)	G	
2-160105.N	50 mm	30 mm	50 mm	12 mm	0,20 kg	36 £ •
2-160113.N	90 mm	30 mm	90 mm	12 mm	0,34 kg	58 £ •

Stop and Clamping Square 90 X nitrided
elongated hole



	L (a)	B (b)	H (c)	MS (d)	G	
2-160108.N	90 mm	30 mm	25 mm	12 mm	0,19 kg	42 £ •

Stop and Clamping Square 90 WL nitrided
elongated hole



	L (a)	B (b)	H (c)	MS (d)	G	
2-160111.N	90 mm	30 mm	90 mm	12 mm	0,27 kg	61 £ •

Stop and Clamping Square 90 SL / 90 L / 140 L nitrided
combination of borehole and elongated hole

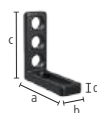

	L (a)	B (b)	H (c)	MS (d)	G	
2-160109.N	90 mm	30 mm	40 mm	12 mm	0,21 kg	44 £ •
2-160110.N	90 mm	30 mm	90 mm	12 mm	0,31 kg	58 £ •
2-160112.N	90 mm	35 mm	140 mm	12 mm	0,51 kg	69 £ •

Stop and Clamping Square 140 WL nitrided
combination of borehole and elongated hole, elongated hole 100 mm



	L (a)	B (b)	H (c)	MS (d)	G	
2-160115.N	140 mm	35 mm	90 mm	12 mm	0,44 kg	67 £ •

Stop and Clamping Square 90 L Aluminum
combination of borehole and elongated hole

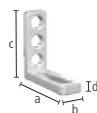

	L (a)	B (b)	H (c)	MS (d)	G	
2-160110.A	90 mm	30 mm	90 mm	12 mm	0,11 kg	67 £ •



Stop and Clamping Square 150 L nitrided
combination of borehole and elongated hole



	L (a)	B (b)	H (c)	MS (d)	G	
2-160114.N	90 mm	35 mm	150 mm	12 mm	0,65 kg	73 £ •

Stop and Clamping Square 300 G / 500 G nitrided
usable as table extension, material: GGG40



	L (a)	B (b)	H (c)	MS (d)	G	
2-160162.N left	150 mm	49 mm	300 mm	12 mm	2,51 kg	95 £ •
2-160164.N left	195 mm	49 mm	500 mm	12 mm	4,56 kg	133 £ •

Rotation Angle 150 nitrided
180° infinite adjustment



	H (c)	MS (d)	Ø	G	
2-160101.N	150 mm	12 mm	150 mm	1,80 kg	98 £ •

Stop and Clamping Square 250 G with rotation angle nitrided
usable as table extension, material: GGG40, recommended as a pair



	L (a)	B (b)	H (c)	MS (d)	G	
2-160161.N left	145 mm	49 mm	250 mm	14 mm	2,16 kg	132 £ •
2-160163.N right	145 mm	49 mm	250 mm	14 mm	2,16 kg	132 £ •

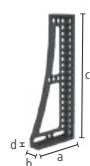

Stop and Clamping Square 250 GK / 500 GK / 750 GK nitrided

usable as table extension, for heavy components, material: GGG40, recommended as a pair



		L (a)	B (b)	H (c)	MS (d)	G	
2-160124.N	left	145 mm	49 mm	250 mm	14 mm	2,10 kg	129 £ •
2-160126.N	right	145 mm	49 mm	250 mm	14 mm	2,10 kg	129 £ •
2-160134.N	left	195 mm	49 mm	500 mm	14 mm	5,30 kg	197 £ •
2-160136.N	right	195 mm	49 mm	500 mm	14 mm	5,30 kg	197 £ •
2-160146.N	left	200 mm	100 mm	750 mm	14 mm	8,30 kg	339 £ •
2-160148.N	right	200 mm	100 mm	750 mm	14 mm	8,30 kg	339 £ •



Corner Connection, Cast Iron nitrided

45° diagonal table extension, material: GGG40



	L (a)	B (b)	H (c)	G	
2-160190.N	100 mm	65 mm	100 mm	1,70 kg	175 £ •

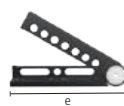

Universal Angle Hydromechanical Clamping nitrided

225° infinite adjustment, suitable matching hex wrench 6 (280852.1) not included



	SL (e)	G	
2-160171.N	250 mm	2,80 kg	515 £ •

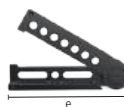

Universal Angle Mechanical Clamping nitrided

includes setting template, 10° to 150° adjustment



	SL (e)	G	
2-160170.N	260 mm	3,40 kg	340 £ •



Support and Clamping Frame small / large nitrided

usable as table extension



		L (a)	B (b)	H (c)	G	
2-160300.N	right	150 mm	100 mm	50 mm	2,10 kg	175 £ •
2-160301.N	left	150 mm	100 mm	50 mm	2,10 kg	175 £ •
2-160302.N		300 mm	200 mm	50 mm	7,40 kg	272 £ •



Clamping Block Plasma nitrided

five-sided, to connect tables (with connecting bolt 160563), as table extension and vertical superstructure



	L (a)	B (b)	H (c)	MS (d)	G	
2-160280.P	300 mm	300 mm	100 mm	12 mm	16 kg	443 £ •
2-160272.P	400 mm	200 mm	200 mm	12 mm	25 kg	674 £ •
2-160290.P	500 mm	500 mm	100 mm	12 mm	40 kg	943 £ •



Square U-Shape 100x100 Plasma nitrided

to connect tables (with connecting bolt 160563), as table extension and vertical superstructure, from 500 mm with mounting holes for table legs, from 1000 mm support through table leg required



	L (a)	B (b)	H (c)	MS (d)	G	
2-160396.P	100 mm	100 mm	100 mm	12 mm	4 kg	321 £ •
2-160360.P	500 mm	100 mm	100 mm	12 mm	15 kg	459 £ •
2-160370.P	1000 mm	100 mm	100 mm	12 mm	27 kg	737 £ •
2-160380.P	1500 mm	100 mm	100 mm	12 mm	39 kg	901 £ •
2-160390.P	2000 mm	100 mm	100 mm	12 mm	51 kg	1.330 £ •



Square U-Shape 200x100 Plasma nitrided

to connect tables (with connecting bolt 160563), as table extension and vertical superstructure, from 500 mm with mounting holes for table legs, from 1000 mm support through table leg required



	L (a)	B (b)	H (c)	MS (d)	G	
2-160396.1.P	200 mm	100 mm	100 mm	12 mm	6 kg	347 £ •
2-160360.1.P	500 mm	200 mm	100 mm	12 mm	22 kg	584 £ •
2-160370.1.P	1000 mm	200 mm	100 mm	12 mm	38 kg	1.007 £ •
2-160380.1.P	1500 mm	200 mm	100 mm	12 mm	55 kg	1.333 £ •
2-160390.1.P	2000 mm	200 mm	100 mm	12 mm	72 kg	1.786 £ •



You can find more information and accessories for these products online.



www.siegmund.com/
F-square16

Aluminum profile square

- Quickly ready for use thanks to clamping plates on the front ends
- Flexible mounting options thanks to integrated hexagonal slot
- Lightweight design for easy handling
- Ideal as a table extension or additional vertical clamping surface
- Cost-optimized through integrated components

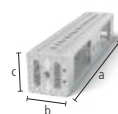

Aluminum profile square 500x100x100 with hexagonal slot

Clamping plate on both ends, with hexagonal slot HX8, as table extension and vertical clamping surface, from 1000 mm support through table leg required, Flatness tolerance < 0,9 mm / 1000 mm

NEW



	L (a)	B (b)	H (c)	G	
4-AQ16HX300	300 mm	100 mm	100 mm	1,90 kg	73 £ •
4-AQ16HX500	500 mm	100 mm	100 mm	3 kg	94 £ •
4-AQ16HX800	800 mm	100 mm	100 mm	4,50 kg	125 £ •
4-AQ16HX1000	1000 mm	100 mm	100 mm	5,50 kg	146 £ •
4-AQ16HX1200	1200 mm	100 mm	100 mm	6,70 kg	167 £ •
4-AQ16HX1500	1500 mm	100 mm	100 mm	8,20 kg	198 £ •
4-AQ16HX2000	2000 mm	100 mm	100 mm	10,80 kg	251 £ •

Sliding Blocks

Set Sliding Block HX8

pack of 4, with thread, attachment of accessories with screw, Galvanized, insertion into the slot from the side, non-slip fit in the slot thanks to a spring ball



16

	L (a)	B (b)	H (c)	G	
2-000551	30 mm	15 mm	7 mm	0,08 kg	10 £ •

Set Sliding Block HX8 rotatable

pack of 4, with thread, attachment of accessories with screw, Galvanized, enables placement in the slot from above, tensions in the slot when turning in the direction of fastening the screw, Further versions available online: with M5 thread



16

	L (a)	B (b)	H (c)	G	
2-000552.2	20 mm	15 mm	7 mm	0,04 kg	10 £ •

Set Sliding Block HX8 insertable

pack of 4, with thread, attachment of accessories with screw, Galvanized, insertion into the slot from above, non-slip fit in the slot thanks to a spring ball, Further versions available online: with M5 thread



16

	L (a)	B (b)	H (c)	G	
2-000553.2	30 mm	12 mm	7 mm	0,08 kg	10 £ •



Aluminum profile bracket

Aluminum profile bracket 100x24 mm (25 mm Grid)

Version with full grid with many clamping options, Requires Clamping Bolt without slot Triple, as table extension and vertical clamping surface, from 1000 mm support through table leg required



	L (a)	B (b)	H (c)	G	
4-AR16014050.V	500 mm	100 mm	24 mm	0,75 kg	29 £ •
4-AR16014080.V	800 mm	100 mm	24 mm	1,20 kg	43 £ •
4-AR16014100.V	1000 mm	100 mm	24 mm	1,50 kg	51 £ •
4-AR16014120.V	1200 mm	100 mm	24 mm	1,80 kg	62 £ •
4-AR16014150.V	1500 mm	100 mm	24 mm	2,24 kg	78 £ •
4-AR16014200.V	2000 mm	100 mm	24 mm	2,93 kg	101 £ •

Aluminum profile bracket 100x24 mm (25 mm Grid with elongated hole)

Variable clamping also possible at an angle, Requires Clamping Bolt without slot Triple, as table extension and vertical clamping surface, from 1000 mm support through table leg required



	L (a)	B (b)	H (c)	G	
4-AR16014050.VL	500 mm	100 mm	24 mm	0,73 kg	33 £ •
4-AR16014080.VL	800 mm	100 mm	24 mm	1,16 kg	50 £ •
4-AR16014100.VL	1000 mm	100 mm	24 mm	1,45 kg	58 £ •
4-AR16014120.VL	1200 mm	100 mm	24 mm	1,73 kg	73 £ •
4-AR16014150.VL	1500 mm	100 mm	24 mm	2,16 kg	90 £ •
4-AR16014200.VL	2000 mm	100 mm	24 mm	2,88 kg	116 £ •

Accessories

Adapter for screw clamps nitrided

for using screw clamps in aluminum profiles, for Screw Clamps: 160610, 160630, 160601, 160604, 160620



	L (a)	Ø	G	
2-AP160605.N	48 mm	26 mm	0,11 kg	13 £ •
2-AP160602.N	60 mm	26 mm	0,13 kg	15 £ •

Oblong adapter for screw clamps

for using screw clamps in aluminum profiles, for Screw Clamps: 160610, 160630, 160601, 160604, 160620, for fixing: Clamping bolt without slot



	L (a)	B (b)	H (c)	G	
2-AP160602.X7	123 mm	23 mm	12 mm	0,19 kg	11 £ •

Round adapter for screw clamps

for using screw clamps in aluminum profiles, for Screw Clamps: 160610, 160630, 160601, 160604, 160620, for fixing: Clamping bolt without slot



	L (a)	B (b)	H (c)	G	
2-AP160603.X7	98 mm	98 mm	12 mm	0,60 kg	14 £ •



You can find more information and accessories for these products online.



www.siegmund.com/
F-profile



Areal Clamping Bolt burnished

160590: Clamping range approx. 22-26 mm, 160590.3: Clamping range approx. 34-38 mm, 160590.4: Clamping range approx. 46-50 mm, recommended for clamping aluminum profiles, MUST NOT be used for connecting tables and U-shaped squares

B 16

		L (a)	SK	ZK1	ZK	AM1	AM	G	
2-160590	double	55 mm	50 kN	2 kN	4 kN	10 Nm	10 Nm	0,11 kg	48 £ •
2-160590.3	triple	67 mm	50 kN	2 kN	4 kN	10 Nm	10 Nm	0,13 kg	53 £ •
2-160590.4	quadruple	79 mm	50 kN	2 kN	4 kN	10 Nm	10 Nm	0,14 kg	58 £ •



Areal Clamping Flush Mount Bolt burnished

countersunk connection of components, 160595: Clamping range approx. 22-26 mm, 160595.3: Clamping range approx. 34-38 mm, 160595.4: Clamping range approx. 46-50 mm, not suitable for elongated holes, MUST NOT be used for connecting tables and U-shaped squares

B 16

		L (a)	SK	ZK1	ZK	AM1	AM	G	
2-160595	double	33 mm	45 kN	2 kN	3 kN	10 Nm	10 Nm	0,05 kg	42 £ •
2-160595.3	triple	45 mm	45 kN	2 kN	3 kN	10 Nm	10 Nm	0,07 kg	47 £ •
2-160595.4	quadruple	57 mm	45 kN	2 kN	3 kN	10 Nm	10 Nm	0,08 kg	52 £ •



Fast Clamping Bolt without slot burnished

without O-ring slot for a smooth surface, MUST NOT be used for connecting tables and U-shaped squares

B 16

		L (a)	SK	ZK	AM1	AM	G	
2-160511	double	53 mm	55 kN	10 kN	2,50 Nm	10 Nm	0,08 kg	40 £ •
2-160513	triple	65 mm	55 kN	10 kN	2,50 Nm	10 Nm	0,10 kg	48 £ •
2-160515	quadruple	77 mm	55 kN	10 kN	2,50 Nm	10 Nm	0,12 kg	56 £ •

Style: double / triple / quadruple



Flush Mount Bolt without slot burnished

countersunk connection of components, only for clamping aluminum profiles, tighten aluminum parts only hand-tight



B 16

		L (a)	SK	ZK	AM1	AM	G	
2-AP160528	double	32 mm	55 kN	1 kN	2,50 Nm	10 Nm	0,04 kg	33 £ •
2-AP160529	triple	44 mm	55 kN	1 kN	2,50 Nm	10 Nm	0,06 kg	40 £ •
2-AP160530	quadruple	56 mm	55 kN	1 kN	2,50 Nm	10 Nm	0,08 kg	45 £ •

Flush Mount Bolt burnished

countersunk connection of components, MUST NOT be used for connecting tables and U-shaped squares, not suitable for aluminum profiles, not suitable for elongated holes



B 16

		L (a)	SK	ZK	AM	G	
2-160528	double	31 mm	55 kN	3 kN	10 Nm	0,04 kg	33 £ •
2-160529	triple	43 mm	55 kN	3 kN	10 Nm	0,05 kg	40 £ •

Connecting Bolt with collar burnished

to connect tables, U-squares and aluminum profiles, suitable for elongated holes, fixed long-term connection



B 16

		L (a)	SK	ZK	AM1	AM	G	
2-160583	double	39 mm	55 kN	3 kN	12 Nm	14,40 Nm	0,07 kg	24 £ •
2-160584	triple	51 mm	55 kN	3 kN	12 Nm	14,40 Nm	0,09 kg	29 £ •
2-160585	quadruple	63 mm	55 kN	3 kN	12 Nm	14,40 Nm	0,11 kg	33 £ •

Fast Clamping Bolt flat without slot burnished

minimal protrusion, MUST NOT be used for connecting tables and U-shaped squares, suitable for aluminum profiles, suitable for elongated holes



B 16

		L (a)	SK	ZK	AM1	AM	G	
2-160524	double	36 mm	55 kN	10 kN	2,50 Nm	10 Nm	0,06 kg	34 £ •
2-160525	triple	48 mm	55 kN	10 kN	2,50 Nm	10 Nm	0,08 kg	42 £ •



Fast Clamping Bolt adjustable without slot burnished

160571: Clamping range approx. 12-24 mm, 160573: Clamping range approx. 24-36 mm, clamping of customized laser cut profiles, suitable for aluminum profiles, tighten aluminum parts only hand-tight, MUST NOT be used for connecting tables and U-shaped squares



		L (a)	SK	ZK	AM1	AM	G	
2-160571	double	78 mm	55 kN	10 kN	2,50 Nm	10 Nm	0,13 kg	44 £
2-160573	triple	90 mm	55 kN	10 kN	2,50 Nm	10 Nm	0,15 kg	53 £



Universal Bolt burnished

160532: Clamping range approx. 22-28 mm, 160533: Clamping range approx. 34-40 mm, MUST NOT be used for connecting tables and U-shaped squares



		L (a)	SK	ZK	AM1	AM	G	
2-160532	double	59 mm	50 kN	10 kN	2,50 Nm	10 Nm	0,11 kg	41 £
2-160533	triple	71 mm	50 kN	10 kN	2,50 Nm	10 Nm	0,12 kg	51 £



Magnetic Clamping Bolt Aluminum

clamping without the use of tools, suitable for pressure-sensitive parts or when counterholding is not possible



		HK	L (a)	SF	G	
2-160740		0,10 kN	34 mm	12 mm	0,02 kg	17 £
2-160740.1		0,10 kN	46 mm	24 mm	0,03 kg	19 £
2-160740.2		0,10 kN	58 mm	36 mm	0,04 kg	22 £

Spacer Ring for Magnetic Bolt burnished

distance between two clamping elements



		L (a)	G	
2-160539		12 mm	0,02 kg	2 £



Connecting Bolt XL burnished

to connect tables and U-squares, not suitable for aluminum profiles, not suitable for elongated holes, fixed long-term connection, hardened



		L (a)	SK	ZK	AM	G	
2-160563	double	38 mm	50 kN	10 kN	86 Nm	0,06 kg	20 £
2-160564	triple	50 mm	50 kN	10 kN	86 Nm	0,08 kg	24 £



Positioning Bolt burnished

substitutes a second clamping bolt cost-effectively, MUST NOT be used for connecting tables and U-shaped squares



		L (a)	G	
2-160540		38 mm	0,07 kg	13 £



You can find more information and accessories for these products online.



www.siegmund.com/
F-bolt16

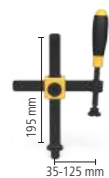

Professional Screw Clamp burnished / nitrided

interchangeable prism, ball diameter spindle 8 mm, Trapezoid thread of spindle 12x3 mm, Vertical Bar reinforced



2-160610

SP	B (b)	H (c)	G
2,50 kN	163 mm	200 mm	1,19 kg

67 £ •



Professional Screw Clamp 45°/90° burnished

interchangeable prism, ball diameter spindle 8 mm, Trapezoid thread of spindle 12x3 mm, stepless rotation from 0-360°



2-160630

SP	H (c)	G
2,50 kN	200 mm	0,72 kg

64 £ •

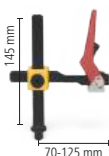

Professional Fast Tension Clamp burnished / nitrided

recommended only for plasma nitrided welding tables, Vertical Bar reinforced



2-160606

SP	B (b)	H (c)	G
2,50 kN	132 mm	150 mm	1,20 kg

91 £ •

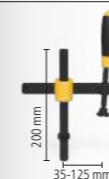

Screw Clamp with Round Pipe burnished

interchangeable prism, ball diameter spindle 8 mm, Trapezoid thread of spindle 12x3 mm, suitable for simple clamping applications, fastening with an adjusting ring



2-160601

SP	B (b)	H (c)	G
1,50 kN	163 mm	200 mm	0,95 kg

67 £ •



Pipe Clamp Universal burnished

interchangeable prism, ball diameter spindle 8 mm, Trapezoid thread of spindle 12x3 mm, clamping at an angle of +/- 42°, fastening with an adjusting ring



2-160604

SP	B (b)	H (c)	G
0,60 kN	165 mm	150 mm	0,70 kg

68 £ •



Basic Screw Clamp burnished / nitrided

interchangeable prism, ball diameter spindle 8 mm, Trapezoid thread of spindle 12x3 mm, Vertical Bar reinforced



2-160620

SP	B (b)	H (c)	G
2,50 kN	128 mm	200 mm	0,95 kg

37 £ •



Short Arbor with Bushing and Prism burnished

trapezoid thread 12x3 mm, usable in every system borehole



2-160666

H (c)	G
75 mm	0,08 kg

26 £ •



Thread Bushing burnished

trapezoid thread 12x3 mm, usable in every system borehole



2-160618

H (c)	Ø	G
10 mm	19 mm	0,01 kg

14 £ •



You can find more information and accessories for these products online.



www.siegmund.com/
F-clamp16

Prism for Screw Clamps

for spindle with ball diameter 8 mm, compatible with 16 mm boreholes and clamps



		H (c)	Ø	G	
2-160656	16 B	14 mm	25 mm	0,03 kg	10 £ •
2-160656.E	16 E	14 mm	25 mm	0,03 kg	14 £ •
2-160656.PA	16 PA	14 mm	25 mm	0,01 kg	10 £ •

Pressure Ball for Screw Clamps

for spindle with ball diameter 8 mm, only suitable for clamps, for clamping in corners or grooves



		H (c)	Ø	G	
2-160660	16 B	13 mm	20 mm	0,02 kg	10 £ •
2-160660.E	16 E	13 mm	20 mm	0,02 kg	14 £ •
2-160660.PA	16 PA	13 mm	20 mm	0,01 kg	11 £ •

Pressure Ball Blank for Screw Clamps burnished

compatible with 16 mm boreholes and clamps, as specified by customer



		H (c)	Ø	G	
2-160661	B 16	25 mm	25 mm	0,07 kg	17 £ •

Duo Prism Ø 25

for spindle with ball diameter 8 mm, only suitable for clamps



		H (c)	Ø	G	
2-160650	16 B	19 mm	25 mm	0,04 kg	14 £ •
2-160650.A	16 AL	19 mm	25 mm	0,02 kg	17 £ •
2-160650.PA	16 PA	19 mm	25 mm	0,01 kg	14 £ •

Quick-Change Clamp 100

Length clamping arm 100 mm, Clamping range 0-100 mm, Mounting in system boreholes



	L (a)	B (b)	H (c)	G	
2-160706	340 mm	30 mm	150 mm	0,70 kg	70 £ •

Quick-Change Clamp 160

Length clamping arm 160 mm, Clamping range 0-140 mm, Mounting in system boreholes



	L (a)	B (b)	H (c)	G	
2-160707	360 mm	30 mm	150 mm	0,90 kg	70 £ •

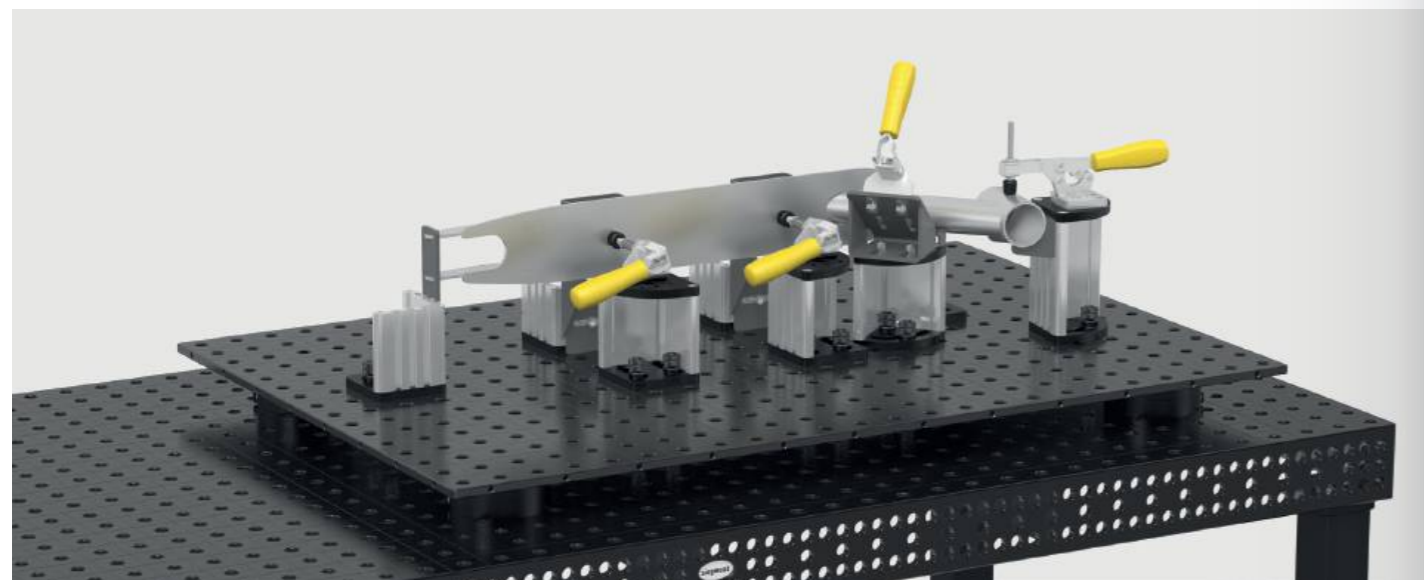

Vertical clamp 1800 with Adapter

Adapter CS160715.4, for system borehole 16 mm



	SP	G	Special offer price
4-CS160790	1,80 kN	0,79 kg	53 £ •
			instead of 57 £

Horizontal clamp 1800 with Adapter

Adapter CS160715.4, for system borehole 16 mm



	SP	G	Special offer price
4-CS160794	1,80 kN	0,79 kg	51 £ •
			instead of 54 £

Horizontal Toggle Clamp 2500 with Adapter

Adapter CS160715.4, for system borehole 16 mm



	SP	G	Special offer price
4-CS160792	2,50 kN	0,87 kg	65 £ •
			instead of 69 £

Horizontal Toggle Clamp 4000 with Adapter

Adapter CS160715.4, for system borehole 16 mm



	SP	G	Special offer price
4-CS160793	4 kN	1,36 kg	81 £ •
			instead of 87 £

Clamping claws

Clamping claw 2-12 / 18-32

Aluminum, CS160212: Clamping range 2-12 mm, CS161832: Clamping range 18-32 mm, for fixing: Bolt 160532 (not included in the delivery)



	L (a)	B (b)	H (c)	G		
2-CS160212	2-12	103 mm	30 mm	20 mm	0,06 kg	13 £ •
2-CS161832	18-32	103 mm	30 mm	35 mm	0,06 kg	13 £ •

Set Clamping claw

Delivery contents: 4x Clamping claw 2-12 CS160212, 4x Clamping claw 18-32 CS161832, 4x Bolt 160532



	G	
2-CS160212.Set	0,92 kg	186 £ •

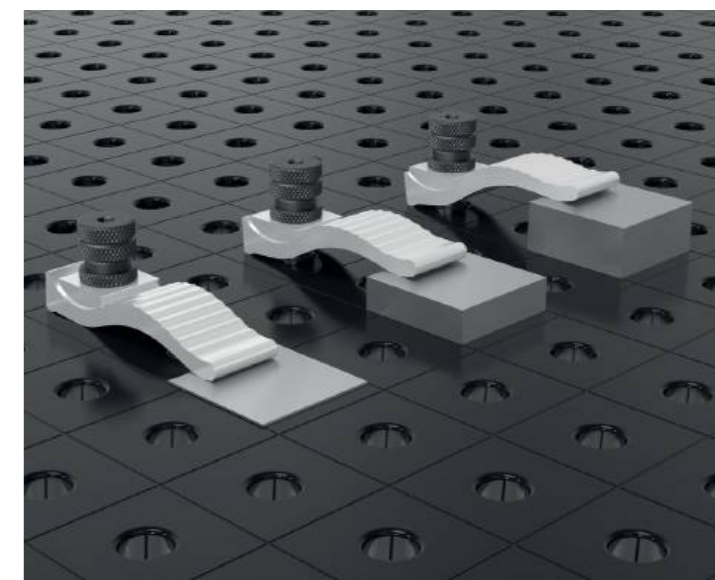
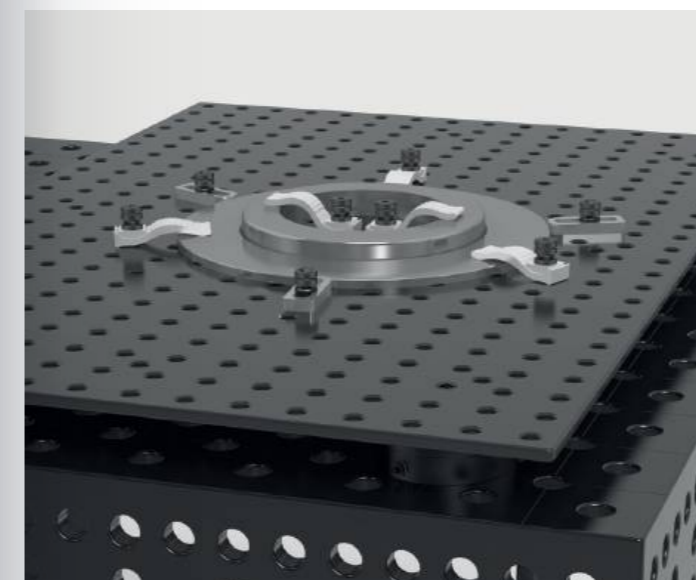

Vario Prism Ø 50 90°/120° with screwed-in collar

M10 thread for e.g. prism extensions Item No. 160649, for round and square pipes up to Ø 80 mm



		H (c)	Ø	G	
2-160645.1.N	16 N BAR	20 mm	50 mm	0,21 kg	42 £ •
2-160645.1.A	16 AL	20 mm	50 mm	0,07 kg	57 £ •
2-160645.1.PA	16 PA	20 mm	50 mm	0,03 kg	54 £ •

Prism Ø 80 120° with screwed-in collar

M10 thread for e.g. prism extensions Item No. 160649, for pipes up to Ø 120 mm

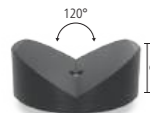

		H (c)	Ø	G	
2-160652.1	16 B	30 mm	80 mm	0,77 kg	47 £ •
2-160652.1.A	16 AL	30 mm	80 mm	0,26 kg	70 £ •
2-160652.1.PA	16 PA	30 mm	80 mm	0,12 kg	70 £ •

Vario Prism Ø 50 90°/120° without collar burnished

Prism can be fastened with bolts, for round and square pipes up to Ø 80 mm



		H (c)	Ø	G	
2-160641		35 mm	50 mm	0,39 kg	43 £ •

Clamping Cone burnished

for holding round and square pipes up to Ø 45 mm, clamping with bolts



		H (c)	Ø	G	
2-160670		40 mm	45 mm	0,26 kg	18 £ •



Screw Support Ø 50 burnished

vernier adjustment height in a range of 55-75 mm, combinable with support set 160821 and prism extension



		H (c)	Ø	G	
2-160822		55-75 mm	50 mm	0,71 kg	39 £ •

Support height adjustable with scale burnished

incl. Set screw, height infinite adjustable between 20-105 mm, Set screw for connecting with prisms



		H (c)	Ø	G	
2-160824		125 mm	40 mm	0,33 kg	48 £ •

Set of Supports 7 pieces burnished

compensation of 1-60 mm height difference, with M10 thread



		H (c)	Ø	G	
2-160821		65 mm	25 mm	0,17 kg	44 £ •

Tower for Supports burnished

variable support surface, with M10 thread



		H (c)	Ø	G	
2-160821.1		65 mm	25 mm	0,09 kg	22 £ •

Washer Set

gradation of discs: 1 / 2 / 3 / 5 / 10 / 20 mm



		Ø	G	
2-160821.2		25 mm	0,08 kg	22 £ •

Prism Extension burnished

compatible with prisms, support set 160821 and screw support 160822



		L (a)	Ø	G	
2-160649.1		50 mm	16 mm	0,08 kg	20 £ •
2-160649.2		100 mm	16 mm	0,15 kg	25 £ •

Prism Collar Screw burnished

to mount prisms in boreholes



		L (a)	Ø	G	
2-160649		10 mm	16 mm	0,02 kg	8 £ •

Special screw

for prisms system 16



		L (a)	Ø	G	
2-160649.0		10 mm	16 mm	0,02 kg	8 £ •



You can find more information and accessories for these products online.



www.siegmund.com/
F-prism16

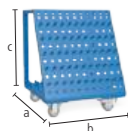

Tool Cart powder coated finish

Max. total weight 240 kg

16

	L (a)	B (b)	H (c)	G	
2-160910	555 mm	560 mm	680 mm	30 kg	647 £ •

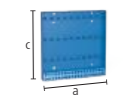

Toolwall powder coated finish

installation to the welding table with bolts or with screws to the wall

16

	L (a)	B (b)	H (c)	G	
2-160912	500 mm	50 mm	500 mm	7,40 kg	261 £ •



Protective Welding Wall

mounting with 2 bolts (16: 000520, 22: 002822, 28: 280511), production-related not scratch proof, Custom color varnish available against surcharge

16 22 28

	L (a)	B (b)	H (c)	G	
2-280980	1600 mm	50 mm	800 mm	23 kg	213 £ •

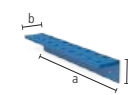

Module for Tool Wall with Sleeves powder coated finish

for Screw Clamp / Prisms / Bolts, back board not included in the delivery

16

	L (a)	B (b)	H (c)	Ø	G	
2-160930	500 mm	80 mm	90 mm	16 mm	1,90 kg	76 £ •

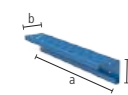

Module for Tool Wall without Sleeves powder coated finish

for Prisms / Bolts, back board not included in the delivery

16

	L (a)	B (b)	H (c)	Ø	G	
2-160931	500 mm	80 mm	90 mm	16 mm	1,60 kg	54 £ •

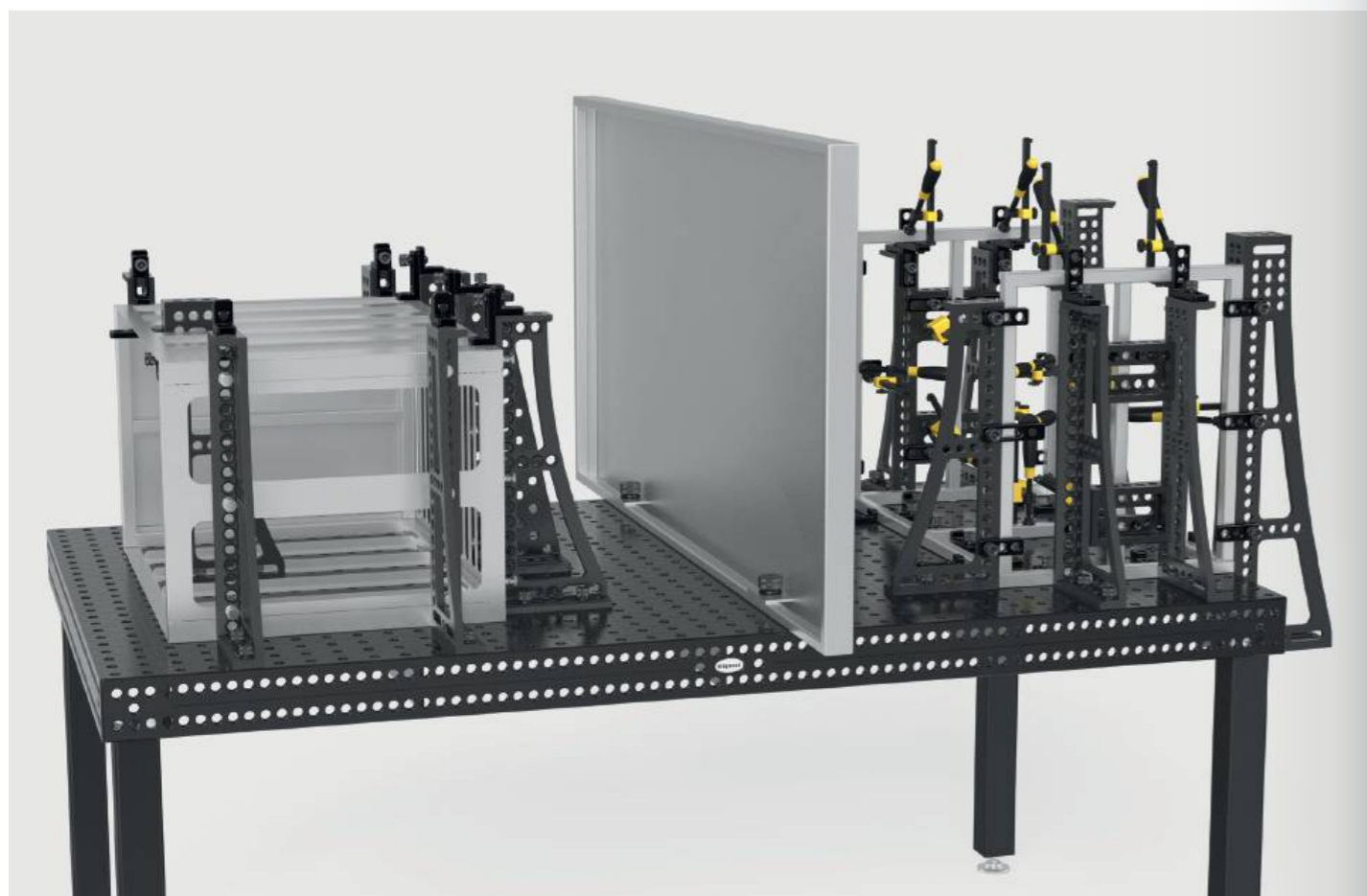

Pin for Toolwall burnished

pack of 10

B 16



	L (a)	Ø	G	
2-160936.10	22 mm	16 mm	0,01 kg	15 £ •

Hex wrench Size 4

yellow

16



	G	
2-160852	0,06 kg	13 £ •

Brush Ø 17 with protecting cover

for cleaning boreholes

16



	Ø	G	
2-160820	17 mm	0,05 kg	18 £ •

Brush Ø 17 for drill bit / 10 piece pack

for cleaning boreholes

16



	Ø	G	
2-160820.10	17 mm	0,05 kg	65 £ •

Burner Holder burnished

can be positioned in borehole

B 16



	H (c)	G	
2-160920	200 mm	0,27 kg	24 £ •

Ground Connection Comfort

guarantees 100% contact to the welding table, Mounting in system boreholes, Load up to 500 ampere, Cable cross section 70-95 mm²

16 22 28



	G	
2-000810	0,66 kg	51 £ •

Lifting lug

for the safe transport of Siegmund welding tables and U-Squares, For fixing: System 16: 4x 160511, Load capacity: 1500 kg (axial load)

NEW

16

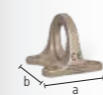

	L (a)	B (b)	H (c)	G	
2-160836	141 mm	141 mm	120 mm	3,10 kg	66 £ •



You can find more information and accessories for these products online.



www.siegmund.com/
F-accessories16

Basic

Sub Table Box lockable for Basic

powder coated finish, Storage space at your welding table, 360 mm space for drawers, lockable, incl. two keys

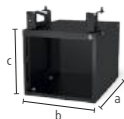

16

	L (a)	B (b)	H (c)	TF	G	
2-161990	630 mm	485 mm	430 mm	100 kg	28,50 kg	386 £ •

Set Sub Table Box lockable for Basic incl. 2 drawers

incl. drawers (2x 004230), powder coated finish, Storage space at your welding table, lockable, incl. two keys, delivered pre-assembled, drawer pull-out length 500 mm

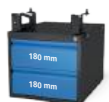

16

	L (a)	B (b)	H (c)	TF	G	Special offer price
2-161990.1	630 mm	485 mm	430 mm	100 kg	42,50 kg	548 £ • instead of 554 £

Set Sub Table Box lockable for Basic incl. 3 drawers

incl. drawers (1x 004220, 1x 004225, 1x 004230), powder coated finish, Storage space at your welding table, lockable, incl. two keys, delivered pre-assembled, drawer pull-out length 500 mm

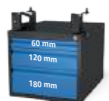

16

	L (a)	B (b)	H (c)	TF	G	Special offer price
2-161990.2	630 mm	485 mm	430 mm	100 kg	47,50 kg	601 £ • instead of 616 £

Professional 750 / Extreme 8.7

Sub Table Box lockable

powder coated finish, Storage space at your welding table, 360 mm space for drawers, Table size 1000x500 mm not compatible, lockable, incl. two keys

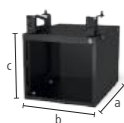

16

	L (a)	B (b)	H (c)	TF	G	
2-160990	630 mm	485 mm	430 mm	100 kg	28,50 kg	386 £ •

Set Sub Table Box lockable incl. 2 drawers

incl. drawers (2x 004230), powder coated finish, Storage space at your welding table, Table size 1000x500 mm not compatible, lockable, incl. two keys, delivered pre-assembled, drawer pull-out length 500 mm

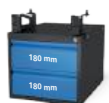

16

	L (a)	B (b)	H (c)	TF	G	Special offer price
2-160990.1	630 mm	485 mm	430 mm	100 kg	42,50 kg	548 £ • instead of 554 £

Set Sub Table Box lockable incl. 3 drawers

incl. drawers (1x 004220, 1x 004225, 1x 004230), powder coated finish, Storage space at your welding table, Table size 1000x500 mm not compatible, lockable, incl. two keys, delivered pre-assembled, drawer pull-out length 500 mm

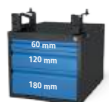

16

	L (a)	B (b)	H (c)	TF	G	Special offer price
2-160990.2	630 mm	485 mm	430 mm	100 kg	47,50 kg	601 £ • instead of 616 £



You can find more information and accessories for these products online.



www.siegmund.com/
F-stbox

Extreme 8.7 PLUS

Sub Table Box lockable for PLUS Table

powder coated finish, Storage space at your welding table, 360 mm space for drawers, lockable, incl. two keys

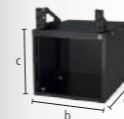

16

	L (a)	B (b)	H (c)	TF	G	
2-162990	630 mm	485 mm	430 mm	100 kg	28 kg	386 £ •

Set Sub Table Box lockable for PLUS Table incl. 2 drawers

incl. drawers (2x 004230), powder coated finish, Storage space at your welding table, lockable, incl. two keys, delivered pre-assembled, drawer pull-out length 500 mm



16

	L (a)	B (b)	H (c)	TF	G	Special offer price
2-162990.1	630 mm	485 mm	430 mm	100 kg	42 kg	548 £ • instead of 554 £

Set Sub Table Box lockable for PLUS Table incl. 3 drawers

incl. drawers (1x 004220, 1x 004225, 1x 004230), powder coated finish, Storage space at your welding table, lockable, incl. two keys, delivered pre-assembled, drawer pull-out length 500 mm



16

	L (a)	B (b)	H (c)	TF	G	Special offer price
2-162990.2	630 mm	485 mm	430 mm	100 kg	47 kg	601 £ • instead of 616 £

Configuration

Drawer with clip rail

powder coated finish, upgrading possible at any time, for Sub Table Box, for Workstation 0806 / 1208 / 1212 with side walls

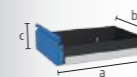

16 22 28

	L (a)	B (b)	H (c)	TF	G	
2-004220	590 mm	400 mm	60 mm	50 kg	5,50 kg	69 £ •
2-004225	590 mm	400 mm	120 mm	50 kg	6,50 kg	77 £ •
2-004230	590 mm	400 mm	180 mm	50 kg	7 kg	85 £ •
2-004235	590 mm	400 mm	240 mm	50 kg	7,50 kg	92 £ •



Bench vice 100

Siegmond bench vice 100

Fastening at a 45° or 90° angle, Jaw width 100 mm, Opening stroke 100 mm, Mounting: System 16: 2x 160511, System 22: 2x 160513 + 2x 000541, System 28: 2x 160511 + 2x 000545



16 22 28

	SP	G	
2-004310	20 kN	9,50 kg	227 £ •

Set of vice jaw covers 100 incl. bag

Delivery contents: 2x Fiber, 2x Rubber, 2x Aluminum neutral, 2x Aluminum prisms



16 22 28

	G	
2-004315	0,70 kg	54 £ •

Set Siegmond bench vice 100 System 16

Fastening at a 45° or 90° angle, Jaw width 100 mm, Opening stroke 100 mm, Delivery contents: 1x Bench vice 004310, 2x Bolt 160511, 1x Set of vice jaw covers 004315



16

	SP	G	
2-164310	20 kN	10,36 kg	334 £ •

Bench vice 125

Siegmond bench vice 125

Fastening at a 45° or 90° angle, Jaw width 125 mm, Opening stroke 125 mm, Mounting: System 16: 2x 160511 + 2x 000546, System 22: 2x 220513 + 2x 000544, System 28: 2x 280511



16 22 28

	SP	G	
2-004320	30 kN	17,50 kg	266 £ •

Set of vice jaw covers 125 incl. bag

Delivery contents: 2x Fiber, 2x Rubber, 2x Aluminum neutral, 2x Aluminum prisms



16 22 28

	G	
2-004325	0,85 kg	59 £ •

Set Siegmond bench vice 125 System 16

Fastening at a 45° or 90° angle, Jaw width 125 mm, Opening stroke 125 mm, Delivery contents: 1x Bench vice 004320, 2x Bolt 160511, 2x Reduction Bushing 000546, 1x Set of vice jaw covers 004325



16

	SP	G	
2-164320	30 kN	18,65 kg	405 £ •

Bench vice 150

Siegmond bench vice 150

Fastening at a 45° or 90° angle, Jaw width 150 mm, Opening stroke 150 mm, Mounting: System 16: 2x 160511 + 2x 000546, System 22: 2x 220513 + 2x 000544, System 28: 2x 280511



16 22 28

	SP	G	
2-004330	40 kN	24 kg	345 £ •

Set of vice jaw covers 150 incl. bag

Delivery contents: 2x Fiber, 2x Rubber, 2x Aluminum neutral, 2x Aluminum prisms



16 22 28

	G	
2-004335	1 kg	67 £ •

Set Siegmond bench vice 150 System 16

Fastening at a 45° or 90° angle, Jaw width 150 mm, Opening stroke 150 mm, Delivery contents: 1x Bench vice 004330, 2x Bolt 160511, 2x Reduction Bushing 000546, 1x Set of vice jaw covers 004335



16

	SP	G	
2-164330	40 kN	25,30 kg	486 £ •

Vice jaw covers

The basic body of the vice jaw covers consists of solid aluminum profiles. The integrated magnets in the profiles hold the covers reliably on the vice and enable quick and easy changing, depending on the workpiece or processing step. Despite the very high magnetic force, workpieces are not magnetized. The vice jaw covers are right-angled and plane-parallel, which means that the high level of accuracy of the Siegmond vice keeps retained.

Set of vice jaw covers

2x Fiber: suitable for finely milled, finely planed, ground or polished surfaces, 2x Rubber: suitable for wooden and plastic parts, 2x Aluminum neutral: secure clamping of coarse to medium-fine machined workpieces thanks to grooves, 2x Aluminum prisms: Clamping of round or oval workpieces using prisms



You can find more information and accessories for these products online.



www.siegmond.com/
F-benchvice

Table press System 16

compressive force of 2,5 tons, total stroke 60 mm, operating force 330 N, fixation always required in two places



	G	
2-160780	6,50 kg	1.180 £ •

Special Square System 16

as an extension and vertical fixation of the press

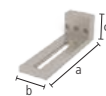

	L (a)	B (b)	H (c)	G	
2-160702	195 mm	60 mm	60 mm	1,41 kg	58 £ •

Thrust Piece

000701.AL: recommended for steel work, 000701.PA: recommended for applications with stainless steel



	H (c)	Ø	G	
2-000701.AL	15 mm	55 mm	0,08 kg	24 £ •
2-000701.PA	15 mm	55 mm	0,03 kg	20 £ •

Stamp 90° with extention pipe

for pressing in corners without damaging the weld seam



	L (a)	B (b)	H (c)	G	
2-000706	168 mm	50 mm	50 mm	0,82 kg	103 £ •

Pipe Adapter POM-C

for straightening pipes, for pipes Ø 21,4 mm: 000703.1, for pipes Ø 26,9 mm: 000703.4, for pipes Ø 33,7 mm: 000703.2, for pipes Ø 42,4 mm: 000703.3



	L (a)	Ø	G	
2-000703.1	35 mm	55 mm	0,08 kg	23 £ •
2-000703.4	35 mm	55 mm	0,08 kg	23 £ •
2-000703.2	35 mm	55 mm	0,08 kg	23 £ •
2-000703.3	35 mm	55 mm	0,07 kg	23 £ •

Pipe Bending Plug POM-C

for bending and straightening pipes, for pipes Ø 21,4 mm: 000704.1, for pipes Ø 26,9 mm: 000704.4, for pipes Ø 33,7 mm: 000704.2, for pipes Ø 42,4 mm: 000704.3



	L (a)	B (b)	H (c)	G	
2-000704.1	120 mm	35 mm	60 mm	0,25 kg	42 £ •
2-000704.4	120 mm	35 mm	60 mm	0,26 kg	42 £ •
2-000704.2	120 mm	35 mm	60 mm	0,25 kg	42 £ •
2-000704.3	120 mm	35 mm	60 mm	0,23 kg	42 £ •

Counter block POM-C

as a counter block for bending and straightening pipes, Plug socket required for fastening, fastened with bolt 160515 / 220515 / 280513 (not included in the delivery), for pipes Ø 21,4 mm: 000705.1, for pipes Ø 26,9 mm: 000705.4, for pipes Ø 33,7 mm: 000705.2, for pipes Ø 42,4 mm: 000705.3

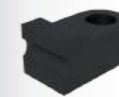

	L (a)	B (b)	H (c)	G	
2-000705.1	60 mm	114 mm	55 mm	0,37 kg	54 £ •
2-000705.4	60 mm	111 mm	55 mm	0,35 kg	53 £ •
2-000705.2	60 mm	102 mm	55 mm	0,31 kg	52 £ •
2-000705.3	60 mm	93 mm	55 mm	0,27 kg	48 £ •

Plug socket

for rotatable fastening of the counter block in the boreholes, for fixing: 160515



	L (a)	Ø	G	
2-160701	48 mm	40 mm	0,26 kg	19 £ •

Product recommendation

Basic-Set

Included in the set: 1x 000701.PA, 1x 000701.AL, 1x 160702



	G	Special offer price
2-160783	1,52 kg	83 £ •
		instead of 102 £

Pipe straightening set for Ø 21,4

Included in the set: 1x 000703.1, 1x 000704.1, 2x 000705.1, 2x 160701, fastened with bolt 160515 (not included in the delivery)



	G	Special offer price
2-160782.1	1,59 kg	169 £ •
		instead of 211 £

Pipe straightening set for Ø 26,9

Included in the set: 1x 000703.4, 1x 000704.4, 2x 000705.4, 2x 160701, fastened with bolt 160515 (not included in the delivery)



	G	Special offer price
2-160782.4	1,56 kg	166 £ •
		instead of 208 £

Pipe straightening set for Ø 33,7

Included in the set: 1x 000703.2, 1x 000704.2, 2x 000705.2, 2x 160701, fastened with bolt 160515 (not included in the delivery)



	G	Special offer price
2-160782.2	1,47 kg	165 £ •
		instead of 206 £

Pipe straightening set for Ø 42,4

Included in the set: 1x 000703.3, 1x 000704.3, 2x 000705.3, 2x 160701, fastened with bolt 160515 (not included in the delivery)



	G	Special offer price
2-160782.3	1,36 kg	160 £ •
		instead of 199 £



You can find more information and accessories for these products online.



www.siegmund.com/
F-tablepress



CROSS-SYSTEM SOLUTIONS



Our Siegmund modular system is based on three different bore sizes. The bore size defines the system. All tool parts and sets can be used on all table series within one system. If you want to work across systems, we also offer an extensive range of connecting elements.



Magnetic Clamping Technology



Duo Magnet Clamping Block 5 / 7 / 10

000780: Retention force 5 kN, Clamping surface (s1) 120x57 mm / (s2) 136x64 mm, 000781: Retention force 7 kN, Clamping surface (s1) 156x57 mm / (s2) 172x64 mm, 000782: Retention force 10 kN, Clamping surface (s1) 162x76 mm / (s2) 178x87 mm

16 22 28

	L (a)	B (b)	H (c)	G	
2-000780	143 mm	64 mm	71 mm	3,90 kg	304 £ •
2-000781	178 mm	64 mm	71 mm	4,90 kg	380 £ •
2-000782	184 mm	87 mm	88 mm	8,80 kg	503 £ •



Special offer Duo Magnet Clamping Block 5

Clamping surface (s1): 120x57 mm, Clamping surface (s2): 136x64 mm, Delivery contents: 2x Duo Magnet Clamping Block + 1x Hex wrench

16 22 28

	L (a)	B (b)	H (c)	G	Special offer price
2-000780.Set	143 mm	64 mm	71 mm	7,80 kg	545 £ • instead of 607 £



Special offer Duo Magnet Clamping Block 7

Clamping surface (s1): 156x57 mm, Clamping surface (s2): 172x64 mm, Delivery contents: 2x Duo Magnet Clamping Block + 1x Hex wrench

16 22 28

	L (a)	B (b)	H (c)	G	Special offer price
2-000781.Set	178 mm	64 mm	71 mm	9,80 kg	682 £ • instead of 758 £



Special offer Duo Magnet Clamping Block 10

Clamping surface (s1): 162x76 mm, Clamping surface (s2): 178x87 mm, Delivery contents: 2x Duo Magnet Clamping Block + 1x Hex wrench

16 22 28

	L (a)	B (b)	H (c)	G	Special offer price
2-000782.Set	184 mm	87 mm	88 mm	17,60 kg	903 £ • instead of 1.005 £

You can find more information and accessories for these products online. www.siegmund.com/F-magnetic

Connecting Elements



Combination Fast Clamping Bolt double burnished

for mounting components from large systems on smaller systems, MUST NOT be used for connecting tables and U-shaped squares

16 22 28

	L (a)	Ø	SK	ZK	AM	G		
2-000520	28 -> 16	75 mm	40 mm	55 kN	10 kN	10 Nm	0,32 kg	57 £ •
2-002822	28 -> 22	88 mm	40 mm	130 kN	15 kN	15 Nm	0,45 kg	57 £ •
2-002216	22 -> 16	71 mm	35 mm	55 kN	10 kN	10 Nm	0,28 kg	53 £ •



Connecting Bolt burnished

to connect tables of different systems, to connect components through boreholes cross-system, not suitable for aluminum profiles

16 22 28

	L (a)	Ø	SK	ZK	AM	G		
2-000562	28 <-> 16	34 mm	32 mm	50 kN	4 kN	15 Nm	0,12 kg	26 £ •
2-028022	28 <-> 22	36 mm	32 mm	120 kN	6 kN	15 Nm	0,11 kg	26 £ •
2-022016	22 <-> 16	27 mm	27 mm	20 kN	4 kN	15 Nm	0,06 kg	24 £ •



Adapter Plate burnished

cross-system mounting of clamps, for clamping components from large systems on smaller systems, mounting with bolts

16 22 28

	L (a)	B (b)	H (c)	G		
2-000570	28 -> 16	150 mm	50 mm	35 mm	0,94 kg	50 £ •



Adapter Plate nitrided

cross-system mounting of clamps, for clamping components from large systems on smaller systems, mounting with bolts

16 22 28

	L (a)	B (b)	H (c)	G		
2-000571.N	28 -> 22	150 mm	50 mm	35 mm	1,09 kg	50 £ •
2-000572.N	22 -> 16	150 mm	50 mm	25 mm	0,83 kg	50 £ •

Reduction Bushing (small to large) burnished

for mounting components from small systems on larger systems, not suitable for elongated holes

16 22 28

	L (a)	Ø	G		
2-000545	16 -> 28	24 mm	32 mm	0,05 kg	15 £ •

Reduction Bushing (small to large) burnished

long clamping bolt required, for mounting components from small systems on larger systems, not suitable for elongated holes

16 22 28

	L (a)	Ø	G		
2-000541	16 -> 22	24 mm	27 mm	0,04 kg	15 £ •
2-000543	22 -> 28	36 mm	32 mm	0,08 kg	15 £ •

Reduction Bushing (large to small) burnished

for clamping components from large systems on smaller systems, fixed inside the component, suitable for elongated holes

16 22 28

	L (a)	Ø	G		
2-000546	28 -> 16	29 mm	36 mm	0,07 kg	15 £ •

Reduction Bushing (large to small) burnished

long clamping bolt required, for clamping components from large systems on smaller systems, fixed inside the component, suitable for elongated holes

22 28

	L (a)	Ø	G		
2-000544	28 -> 22	35 mm	36 mm	0,10 kg	15 £ •
2-000542	22 -> 16	23 mm	31 mm	0,05 kg	15 £ •

Adapter Sleeve burnished

attachment of components in larger system, not suitable for clamping with clamping bolts

16 22 28

	L (a)	Ø	G		
2-000547	16 -> 28	40 mm	30 mm	0,12 kg	17 £ •
2-000549	22 -> 28	25 mm	30 mm	0,04 kg	17 £ •
2-000548	16 -> 22	18 mm	24 mm	0,02 kg	17 £ •

You can find more information and accessories for these products online. www.siegmund.com/F-connecting

Flanges

Clamping Plate 150 lbs with Fixing Bolt nitrided

for flange US standard, ANSI / ASME B 16,5 150 lbs, from 1/2" to 8", Delivery contents: 2x 280255, 2x 280256, 2x 280257, required for system 16: 000562/000520/000546, required for system 22: 028022/002822/000544

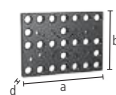

	L (a)	B (b)	MS (d)	G	
2-280250.P	350 mm	250 mm	25 mm	14 kg	633 £ •

Clamping Plate 300 lbs with Fixing Bolt nitrided

for flange US standard, ANSI / ASME B 16,5 300 lbs, from 1/2" to 8", Delivery contents: 2x 280255, 2x 280256, 2x 280257, 2x 280258, 2x 280259, required for system 16: 000562/000520/000546, required for system 22: 028022/002822/000544

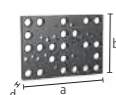

	L (a)	B (b)	MS (d)	G	
2-280251.P	350 mm	250 mm	25 mm	14 kg	719 £ •

Clamping Plate 400-600 lbs with Fixing Bolt nitrided

for flange US standard, ANSI / ASME B 16,5 400-600 lbs, from 1/2" to 6", Delivery contents: 2x 280255, 2x 280256, 2x 280257, 2x 280258, 2x 280259, required for system 16: 000562/000520/000546, required for system 22: 028022/002822/000544

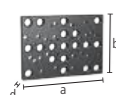

	L (a)	B (b)	MS (d)	G	
2-280252.P	350 mm	250 mm	25 mm	14 kg	749 £ •

Fixing Bolt burnished

for Clamping Plate 280250.P / 280251.P / 280252.P



	L (a)	Ø	G	
2-280255	39 mm	15,50 mm	0,03 kg	17 £ •
2-280256	41 mm	18,90 mm	0,05 kg	17 £ •
2-280257	45 mm	22,20 mm	0,10 kg	18 £ •

Fixing Bolt burnished

for Clamping Plate 280251.P / 280252.P



	L (a)	Ø	G	
2-280258	50 mm	25,20 mm	0,14 kg	25 £ •

Fixing Bolt burnished

for Clamping Plate 280252.P



	L (a)	Ø	G	
2-280259	50 mm	28,20 mm	0,16 kg	28 £ •

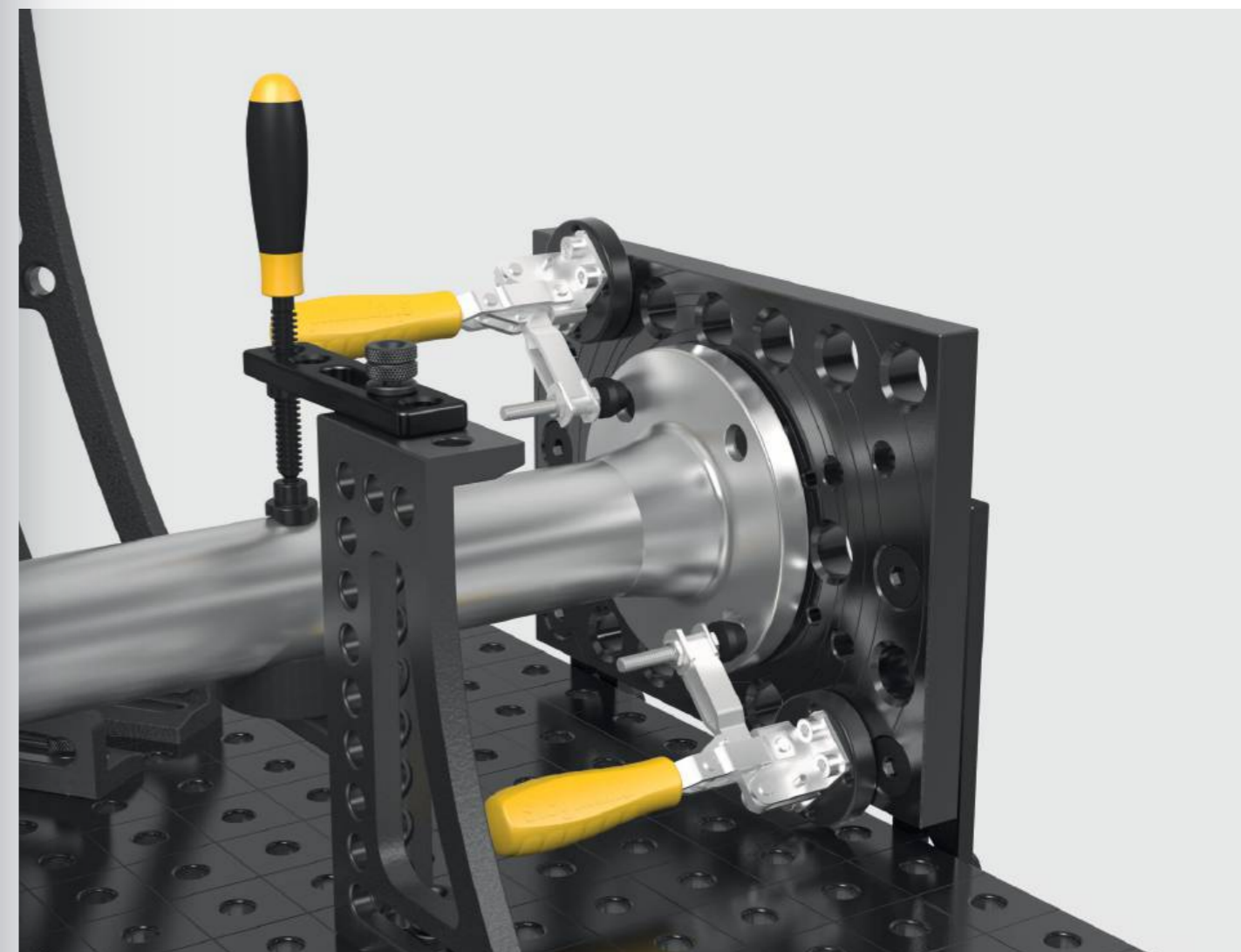
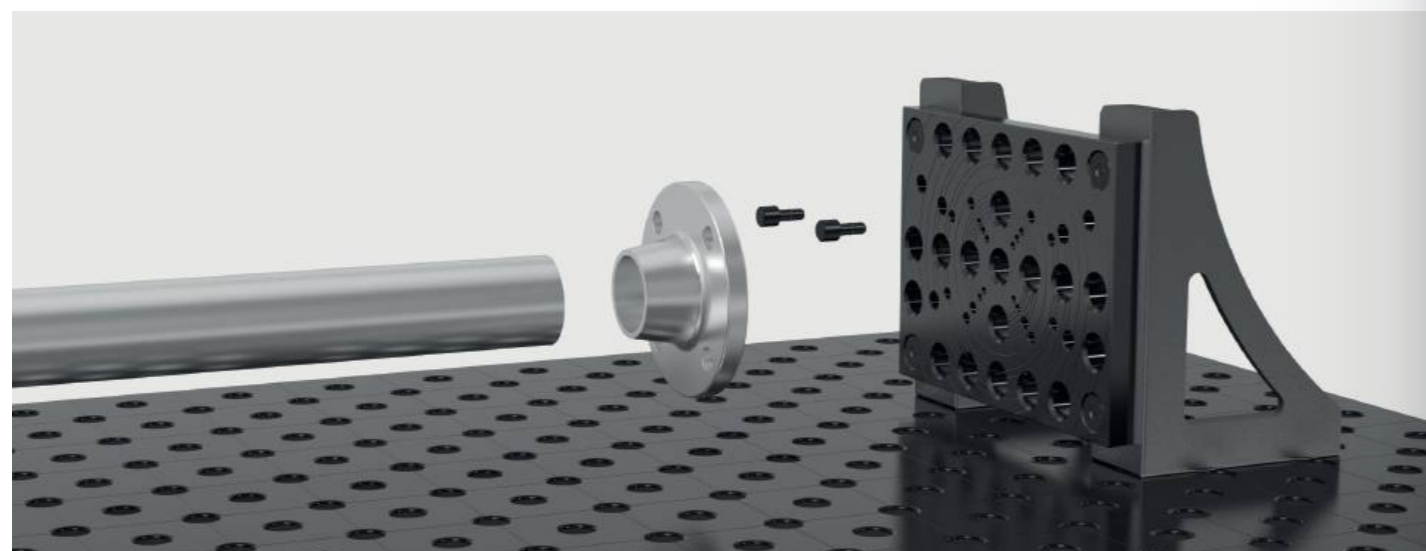

Clamping Plate 550 for DIN Flanges with Fixing Bolt nitrided

Delivery contents: 2x 280222, 2x 280223, 2x 280224, 2x 280225, 2x 280226, 2x 280227, for System 16: 000562/000520/000546, for System 22: 028022/002822/000544

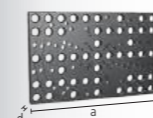

	L (a)	B (b)	MS (d)	G	
2-280220.P	550 mm	350 mm	25 mm	30 kg	686 £ •

Clamping Plate 350 for DIN Flanges with Fixing Bolt nitrided

for flanges DIN 2633, nominal width DN 15 - DN 200, Delivery contents: 2x 280222, 2x 280223, 2x 280224, required for system 16: 000562/000520/000546, required for system 22: 028022/002822/000544

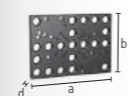

	L (a)	B (b)	MS (d)	G	
2-280221.P	350 mm	250 mm	25 mm	14 kg	583 £ •

Fixing Bolt burnished

for Clamping Plate 280220.P / 280221.P







	L (a)	Ø	G	
2-280222	39 mm	13,80 mm	0,03 kg	14 £ •
2-280223	41 mm	17,80 mm	0,05 kg	14 £ •
2-280224	47 mm	21,80 mm	0,10 kg	14 £ •
2-280225	50 mm	25,80 mm	0,14 kg	22 £ •
2-280226	55 mm	29,80 mm	0,20 kg	22 £ •
2-280227	60 mm	32,80 mm	0,27 kg	22 £ •

You can find more information and accessories for these products online. www.siegmund.com/F-flanges



L: Length, B: Width, MS: Material thickness, G: Weight, Ø: Diameter







Pneumatic Clamps

Pneumatic Cylinder, short Form incl. Adapter System 16				
for automated clamping, Force = 650 N at 8 bar, mounted in borehole with adapter, lifting range 25 mm or 50 mm, depending on pressure cylinder				
				16
0-000850	G	0,90 kg	338 £	◦
Pneumatic Cylinder, short Form incl. Adapter System 28				
for automated clamping, Force = 650 N at 8 bar, mounted in borehole with adapter, lifting range 25 mm or 50 mm, depending on pressure cylinder				
				28
0-000851	G	0,93 kg	323 £	◦
Pneumatic Cylinder, long form for System 28				
for automated clamping, Force = 350 N at 8 bar, mounted in thread holes with threaded bushing system 28, lifting range 25 mm or 50 mm, depending on pressure cylinder				
				28
0-000855	G	0,80 kg	284 £	◦
Manifold 8 Outlets				
for automated clamping, connection between pneumatic cylinder and compressor, operating pressure of 1-10 bar				
				16 28
0-000860	G	0,14 kg	310 £	◦

You can find more information and accessories for these products online.
www.siegmund.com/F-pneumatic

Maintenance products

Oilstone				
to maintain and equalize unevenness on the table surface, suitable for non-nitrided welding tables and accessories				
				16 22 28
	L (a)	B (b)	H (c)	G
2-000942	150 mm	50 mm	25 mm	0,42 kg
2-000940	200 mm	50 mm	25 mm	0,56 kg
CleanBasic 1 liter spray bottle				
water-based cleaner, for daily table cleaning, prevents rusting, safety data sheet available online				
				16 22 28
2-000914	G	1,10 kg	15 £	◦
Special offer CleanBasic 8x 1 liter spray bottle				
water-based cleaner, for daily table cleaning, prevents rusting, safety data sheet available online				
				16 22 28
2-000914.8	G	8,80 kg	114 £	◦
				instead of 125 £

CleanBasic 5 liter				
water-based cleaner, for daily table cleaning, prevents rusting, safety data sheet available online				
				16 22 28
2-000915	G	5,20 kg	50 £	◦
Special offer CleanBasic 6x 5 liter				
water-based cleaner, for daily table cleaning, prevents rusting, safety data sheet available online				
				16 22 28
2-000915.6	G	31,20 kg	264 £	◦
				instead of 294 £
Anti-Spatter 1 liter spray bottle				
Corrosion protection, non-flammable, water soluble Anti-Spatter, prevents the welding table from welding spatter burn-in, safety data sheet available online				
				16 22 28
2-000924	G	1,10 kg	19 £	◦
Special offer Anti-Spatter 8x 1 liter spray bottle				
Corrosion protection, non-flammable, water soluble Anti-Spatter, prevents the welding table from welding spatter burn-in, safety data sheet available online				
				16 22 28
2-000924.8	G	8,80 kg	134 £	◦
				instead of 149 £
Anti-Spatter 1 liter pump bottle				
Corrosion protection, non-flammable, water soluble Anti-Spatter, prevents the welding table from welding spatter burn-in, safety data sheet available online				
				16 22 28
2-000929	G	1,10 kg	41 £	◦
Anti-Spatter 5 liter				
Corrosion protection, non-flammable, water soluble Anti-Spatter, prevents the welding table from welding spatter burn-in, safety data sheet available online				
				16 22 28
2-000926	G	5,20 kg	57 £	◦
Special offer Anti-Spatter 6x 5 liter				
Corrosion protection, non-flammable, water soluble Anti-Spatter, prevents the welding table from welding spatter burn-in, safety data sheet available online				
				16 22 28
2-000926.6	G	31,20 kg	309 £	◦
				instead of 343 £

You can find more information and accessories for these products online.
www.siegmund.com/F-maintenance

Siegmund Roto-Positioner

- Hydraulic rotation of the clamping plate, optionally electric
- Hydraulic height adjustment and tilt function
- Large working area, low design height
- incl. rotatable ground connection: optimal connection to the table plate, no cable twisting
- without table top / octagonal plate
- 6R300M16 / 6R450M16: Recommendation: octagonal tables from a width across flats of at least 1200 mm



Siegmund Roto-Positioner RP 1250

Table revolutions per minute: hydraulic: 2 / electric: 0-2, Operating voltage 400 V 50 Hz, Tilt angle: 95°, Vertical movement range (A): 540-1120 mm, Horizontal movement range (B): 700-1280 mm, Length (C): 1760 mm, Width (D): 1630 mm, Clamping plate diameter (F): Ø 800 mm

	DM	KM	BG (E)	TF	G	
6R120M16	490 Nm	4900 Nm	750 mm	1250 kg	757 kg	29.196 £ ◦

Siegmund Roto-Positioner RP 2000

Table revolutions per minute: hydraulic: 2 / electric: 0-2, Operating voltage 400 V 50 Hz, Tilt angle: 95° (Alternatively 140°), Vertical movement range (A): 550-1300 mm, Horizontal movement range (B): 650-1400 mm, Length (C): 1850 mm, Width (D): 1660 mm, Clamping plate diameter (F): Ø 800 mm

	DM	KM	BG (E)	TF	G	
6R200M16	1570 Nm	7850 Nm	750 mm	2000 kg	930 kg	32.588 £ ◦

Siegmund Roto-Positioner RP 3000

Table revolutions per minute: hydraulic: 2 / electric: 0-2, Operating voltage 400 V 50 Hz, Tilt angle: 95° (Alternatively 140°), Vertical movement range (A): 740-1590 mm, Horizontal movement range (B): 720-1570 mm, Length (C): 2400 mm, Width (D): 1825 mm, Clamping plate diameter (F): 1100x1100 mm

	DM	KM	BG (E)	TF	G	
6R300M16	2350 Nm	11750 Nm	930 mm	3000 kg	1477 kg	37.666 £ ◦

Siegmund Roto-Positioner RP 4500

Table revolutions per minute (electric): 0-1,5, Operating voltage 400 V 50 Hz, Tilt angle: 95° (Alternatively 140°), Vertical movement range (A): 830-2080 mm, Horizontal movement range (B): 880-2130 mm, Length (C): 2590 mm, Width (D): 2270 mm, Clamping plate diameter (F): 1500x1500 mm

	DM	KM	BG (E)	TF	G	
6R450M16	5300 Nm	21200 Nm	1250 mm	4500 kg	2500 kg	56.614 £ ◦

Please note: Maximum load minus weight of table.

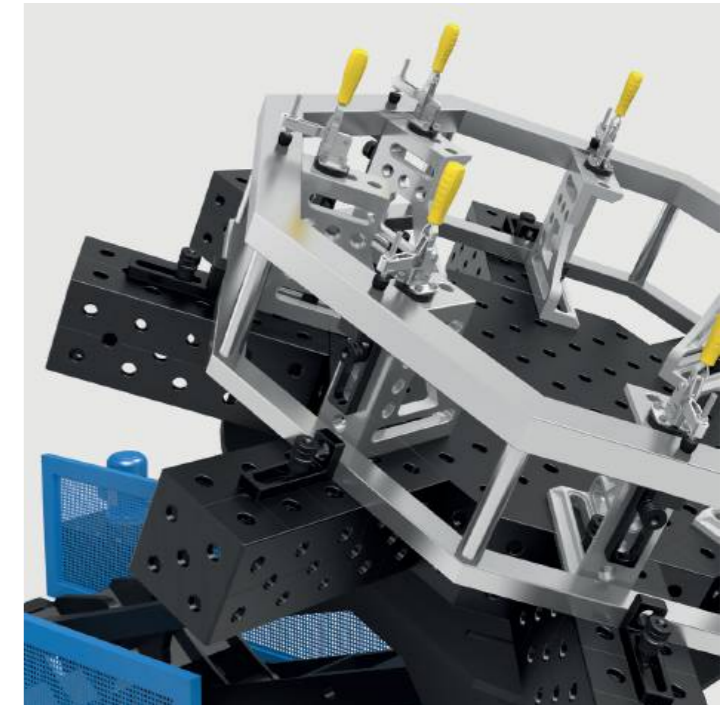
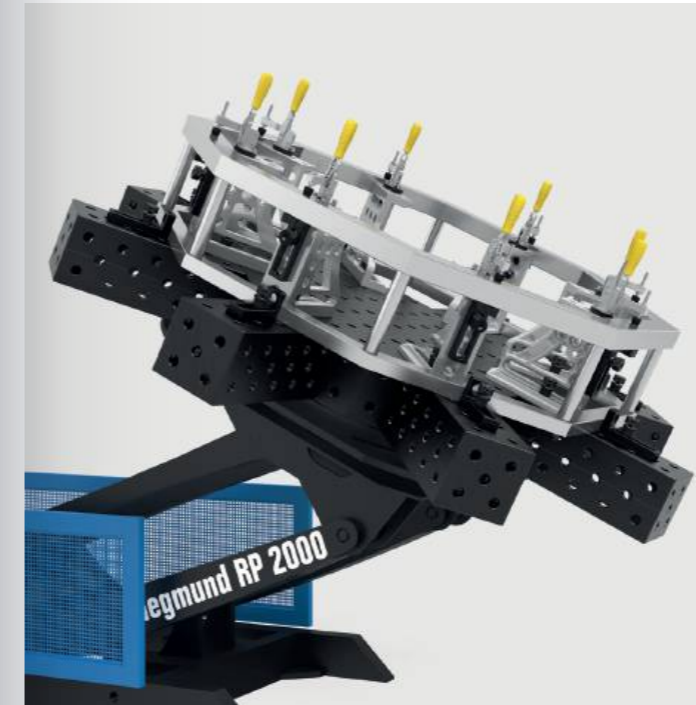
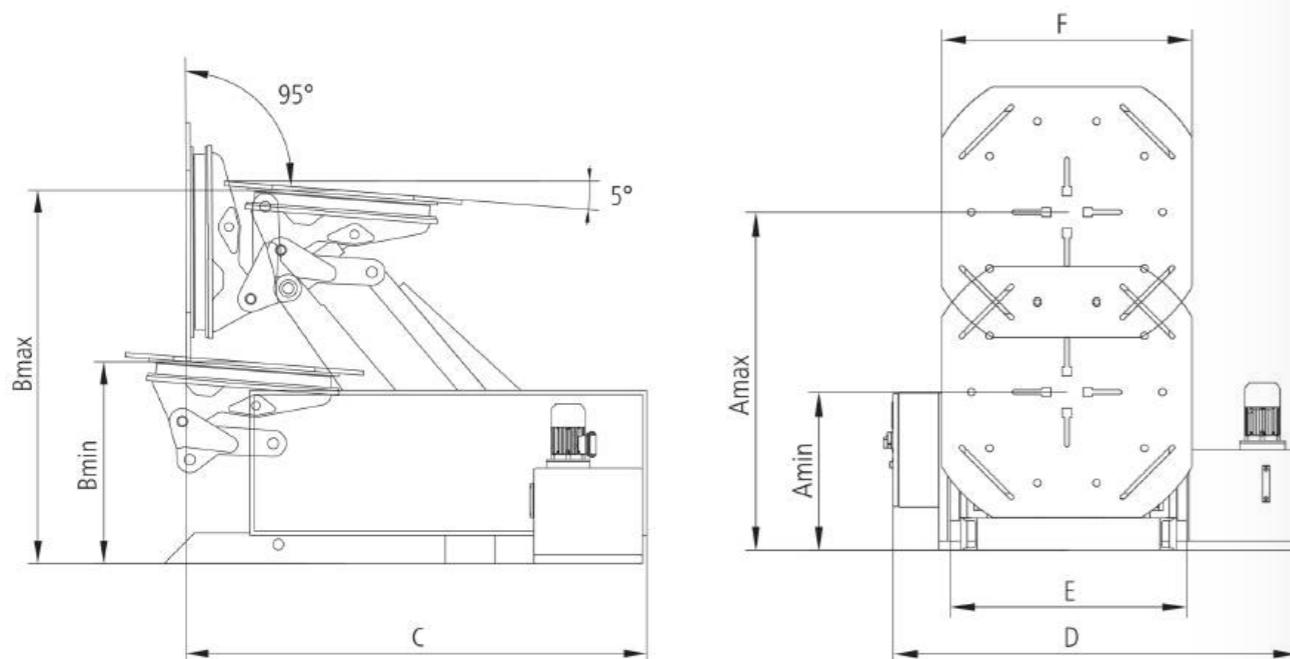

Product recommendation



Manual control (wired)

for RP 1250, RP 2000, RP 3000, RP 4500, included in the basic price (except control panel with teach function), Control buttons for manual setting, incl. Mounting, subsequent installation NOT possible

	G	
6R000150	5 kg	1.293 £ ◦



Manual control (wired) for teach function

suitable for Roto positioners with teach function, subsequent installation is possible, not included in the basic price for positioners with teach function

	G	
6R000151	3,50 kg	1.293 £ ◦



Foot pedal control

for RP 1250, RP 2000, RP 3000, RP 4500, table can be rotated by using the integrated start and stop function, subsequent installation is possible

	G	
6R000250	5 kg	1.870 £ ◦



Control panel with teach function for RP 1250, RP 2000, RP 3000

Programming, saving and repeating of positions, Manual control (wired) available for an extra charge, electric drive (6R000450, 6R000460, 6R000470) absolutely necessary, subsequent installation NOT possible

	G	
6R000550	20 kg	10.588 £ ◦



Control panel with teach function for RP 4500

Programming, saving and repeating of positions, Manual control (wired) available for an extra charge, subsequent installation NOT possible

	G	
6R000560	20 kg	12.018 £ ◦

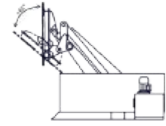

Optional tilt angle 140°

140° tilting of Clamping Plate, rotation of octagonal tables from 1200 mm in the extended position is not possible, subsequent installation NOT possible

6R000350	RP 2000	3.640 £	o
6R000360	RP 3000	4.410 £	o



Electric drive

Infinitely variable speed, Lifting and tilting by hydraulic drive, subsequent installation NOT possible

6R000450	RP 1250	3.319 £	o
6R000460	RP 2000	4.382 £	o
6R000470	RP 3000	4.199 £	o

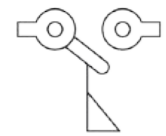

Limit switch for RP 1250, RP 2000, RP 3000

stops the plate when lowering to prevent ground collision, subsequent installation is possible

6R000660		486 £	o
----------	--	-------	---

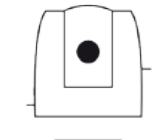

Laser scanner type S300 for Roto positioners and Synchronlift

Protective field area: 3 m, Angle of view: 270°, Scanner resolution: 0,5°, Safety device with protective field area, without programming, Setup and connection by the customer, subsequent installation NOT possible

6RS00000		5.986 £	o
----------	--	---------	---



You can find more information and accessories for these products online.



www.siegmund.com/
F-pos-r

Siegmund M-Positioner

- Drive manually via hand wheel
- Force transmission through a bearing with integrated gear
- Universal flange for clamping of Siegmund U-Squares
- Clamping of components on Siegmund U-Squares
- Stability provided by large flat foot plate for floor anchoring
- without U-Square



Siegmund M-Positioner MP 500 for System 16

Hand wheel with handle Ø 200 mm, Gear ratio: 1:73, Axis of rotation: horizontal, Max. length Square U-Shape: 1500 mm, Working height (A): 850 mm, Tower height (B): 955 mm, Total height (C): 1083 mm, Base plate width (D): 500 mm, Base plate length (E): 400 mm

	DM	TF	G	
6M050016	100 Nm	500 kg	110 kg	6.578 £ o



Siegmund M-Positioner MP 1500 for System 28

Hand wheel with handle Ø 315 mm, Gear ratio: 1:73, Axis of rotation: horizontal, Max. length Square U-Shape: 3000 mm, Working height (A): 850 mm, Tower height (B): 955 mm, Total height (C): 1140 mm, Base plate width (D): 600 mm, Base plate length (E): 600 mm

	DM	TF	G	
6M150016.28	900 Nm	1500 kg	180 kg	6.958 £ o

Please note: Maximum load minus weight of U-Square.

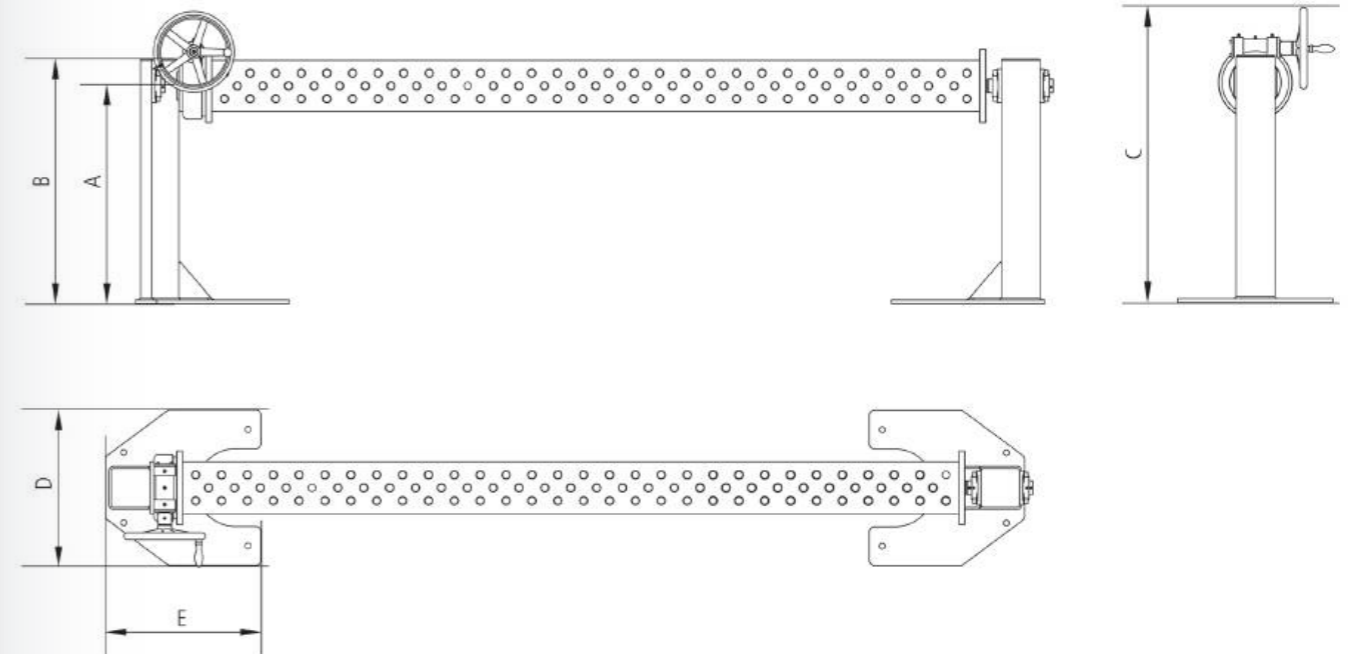

You can find more information and accessories for these products online.



www.siegmund.com/
F-pos-m

Siegmund Synchronlift

- Continuously adjustable rotation of the clamping plate
- High repeat accuracy
- Pallet lifter for repositioning
- Display for positioner setting
- incl. rotatable ground connection: optimal connection to the table plate, no cable twisting
- without table top / octagonal plate



Siegmund Synchronlift SL 2500

Table revolutions per minute (electric): 1, Operating voltage 400 V 50 Hz, Speed lifting and lowering: 56 cm/min, Motor power turning: 0,75 kW, Motor power lifting and lowering: 2 kW, Tower height: 2505 mm, Total stroke (B): 1500 mm, movement range (C): 350-1850 mm, Clamping plate diameter: Ø 600 mm

	DM	TF	G	
65250M16	3000 Nm	2500 kg	1200 kg	40.390 £ ◦



Siegmund Synchronlift SL 4500

Table revolutions per minute (electric): 1, Operating voltage 400 V 50 Hz, Speed lifting and lowering: 56 cm/min, Motor power turning: 0,55 kW, Motor power lifting and lowering: 2 kW, Tower height: 2505 mm, Total stroke (B): 1500 mm, movement range (C): 450-1950 mm, Clamping plate diameter: Ø 600 mm

	DM	TF	G	
65450M16	3750 Nm	4500 kg	1150 kg	48.956 £ ◦



Siegmund Synchronlift SL 7000

Table revolutions per minute (electric): 0,75, Operating voltage 400 V 50 Hz, Speed lifting and lowering: 56 cm/min, Motor power turning: 0,55 kW, Motor power lifting and lowering: 2 kW, Tower height: 2505 mm, Total stroke (B): 1450 mm, movement range (C): 500-1950 mm, Clamping plate diameter: Ø 800 mm

	DM	TF	G	
65700M16	6500 Nm	7000 kg	1300 kg	56.088 £ ◦

Please note: Maximum load minus weight of table.

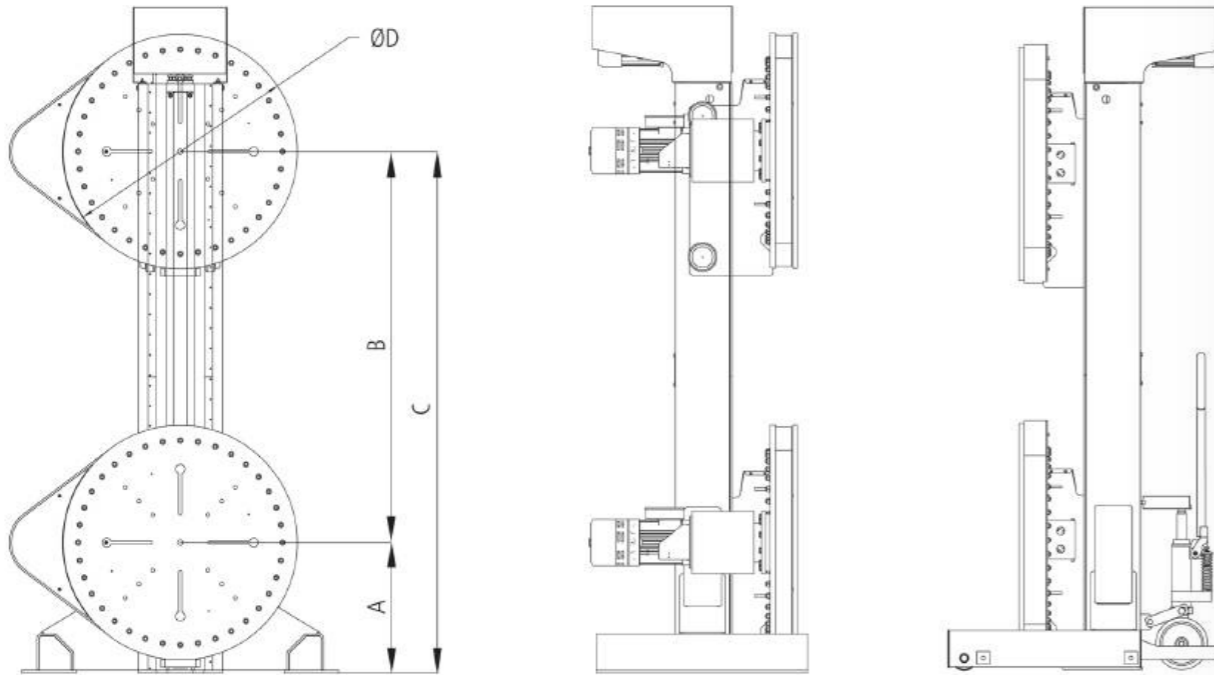

You can find more information and accessories for these products online.



www.siegmund.com/
F-pos-s

Product recommendation



Manual control (wired)

included in the basic price, Control buttons for manual setting, incl. Mounting, subsequent installation NOT possible

65000150	1.271 £ ◦
----------	------------------



Manual control (wired) for teach function

suitable for Synchronlift with teach function, subsequent installation is possible, not included in the basic price for positioners with teach function

	G	
65000151	2,80 kg	1.271 £ ◦



Foot pedal control

table can be rotated by using the integrated start and stop function, subsequent installation is possible

65000250	1.685 £ ◦
----------	------------------



Control panel with teach function

Programming, saving and repeating of positions, subsequent installation NOT possible

	G	
65000550	20 kg	6.738 £ ◦

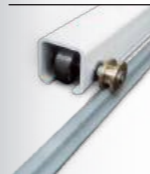

Floor rails Single Rail 2 m

moving towers parallel to each other, subsequent installation is possible

	G	
65000640	10 kg	308 £ ◦



Floor rails Extension Single Rail 2 m

moving towers parallel to each other, subsequent installation is possible

65000641	174 £ ◦
----------	----------------

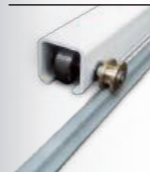

Floor rails Double Rails 2 m

moving towers parallel to each other, subsequent installation is possible

	G	
65000650	20 kg	616 £ ◦

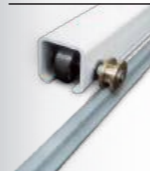

Floor rails Extension Double Rails 2 m

moving towers parallel to each other, subsequent installation is possible

65000651	347 £ ◦
----------	----------------

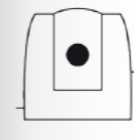

Laser scanner type S300 for Roto positioners and Synchronlift

Protective field area: 3 m, Angle of view: 270°, Scanner resolution: 0,5°, Safety device with protective field area, without programming, Setup and connection by the customer, subsequent installation NOT possible

6RS00000	5.986 £ ◦
----------	------------------



ISSUES, TRENDS, DEVELOPMENTS AND GOOD CONVERSATIONS

Trade fairs reflect the topics, trends and developments in the industry and offer a first-class platform for exchanging experience and knowledge.

We strive to continuously develop new solutions that increase productivity and efficiency. By participating in various trade fairs, we have the opportunity to present our latest developments to a wide and international audience of professionals, customers and interested parties. Good conversations and valuable business contacts round off every trade fair participation.

Visit our booth to see the quality of our products for yourself. We are looking forward to a personal meeting with you.

All exhibition dates in Germany and around the world can be found in our exhibition calendar.



www.siegmund.com/F-exhibition



THE SIEGMUND CONFIGURATOR – BUILT TO BUILD

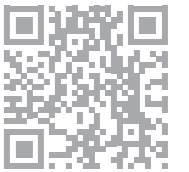

konfigurator.siegmund.com

Configure your projects

Discover the limitless possibilities with the Siegmund product world and configure your own 3D models on our welding and clamping devices. Plan your next project quickly, easily and intuitively and use our entire product range to optimally visualize your designs.

1500+ Variety of tables

1900+ Accessories

400+ Finished projects

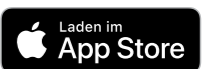
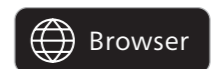

Your advantages



Siegmund products



Own 3D models



Save & Share



Augmented Reality

Prices are quoted in £ sterling excluding VAT, packing and freight costs. We reserve the right to amend prices listed when subject to fluctuations in the Euro/£ sterling exchange rate. Our minimum order value is £ 50. Technical data are subject to change. The sale of Siegmund products from the Oberottmarshausen warehouse, is restricted to a worldwide network of appointed importers with resale through locally appointed distributors only. Our Terms and Conditions of Sale strictly apply. Subject to price changes and printing errors. Siegmund products are subject to continuous improvement and we reserve the right to amend and supersede all products where applicable.

All texts, pictures and design elements are copyrighted by the Bernd Siegmund GmbH. No part of this catalog may be edited analogously or digital or in another mode, may be duplicated or published out of the catalog without written approval of the legal owner. Offences are prosecuted.
© 2025 Bernd Siegmund GmbH

● Item produced for stock

○ Item produced on order

siegmund



**Find our exhibition
calendar at:**

www.siegmund.com/exhibition



Producer:

Bernd Siegmund GmbH

Landsberger Str. 180
86507 Oberottmarshausen
Germany (Bavaria)
Phone +49 8203 96 07-0
info@siegmund.com
siegmund.com

Your distributor: